



CITY OF KENMORE

2021 ROAD STANDARDS EDITION 3

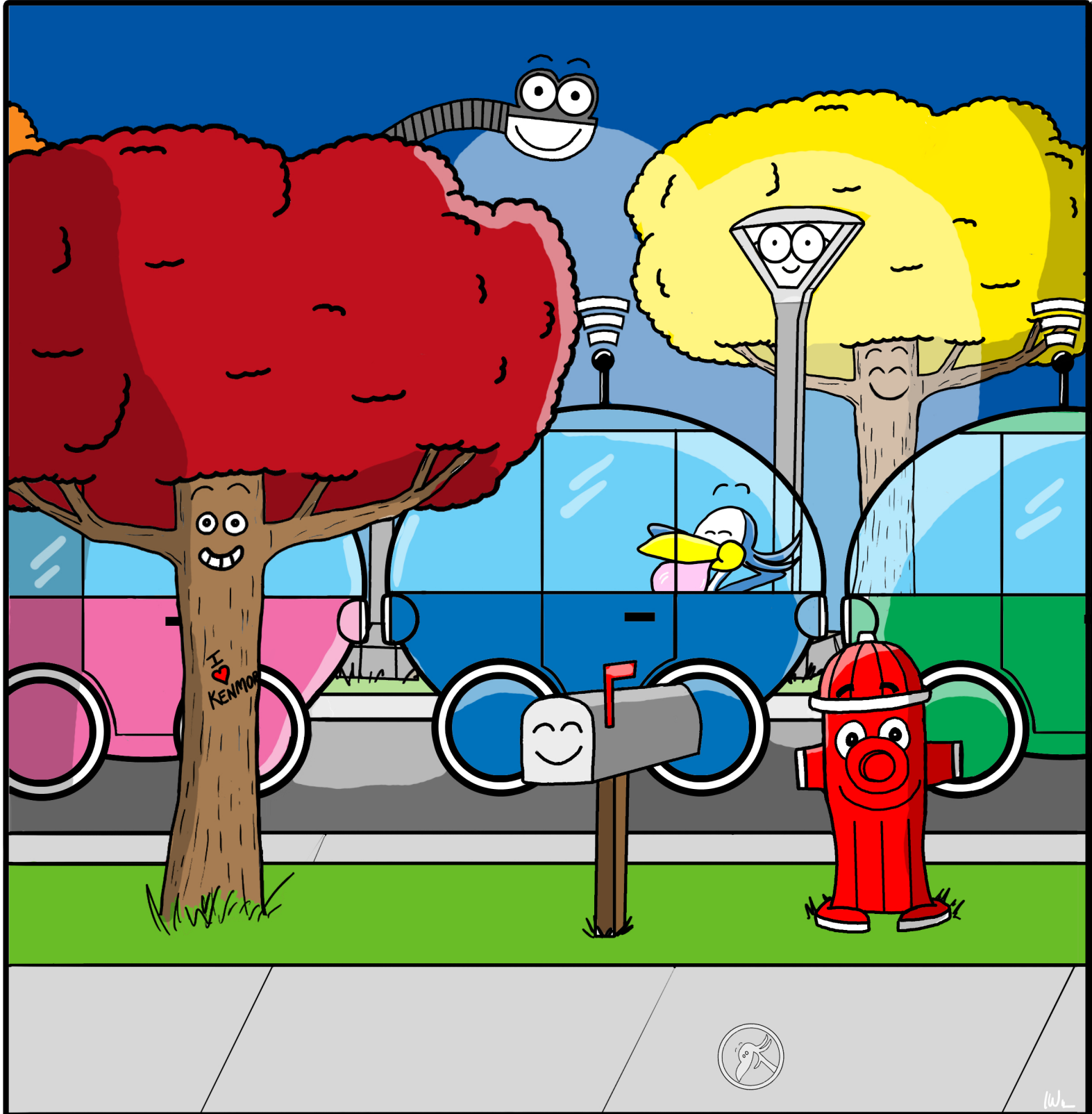

Table of Contents

- Introduction.....5
- Chapter 1: Overview.....6
 - 1.01 Introduction 6
 - 1.02 Definitions, Acronyms, and Abbreviations..... 6
 - 1.03 Companion Documents 9
 - 1.04 Variances..... 10
 - 1.05 Applicability..... 10
 - 1.06 Authority and Duty of Inspectors..... 11
 - 1.07 Cultural Resources 11
 - 1.08 Permits 11
 - 1.09 Engineering Plans, Final Corrected Plans, and Final Plat Plans..... 11
 - 1.10 Errors and Omissions 13
 - 1.11 Penalties and Financial Guarantees..... 13
 - 1.12 Changes to the Road Standards 14
- Chapter 2: General Requirements..... 15
 - 2.01 Responsibility to Provide Frontage Improvements 15
 - 2.02 Fee in Lieu Option 16
 - 2.03 Low Impact Development 16
 - 2.04 Maintenance 17
 - 2.05 Connectivity 17
 - 2.06 Traffic Impact Analyses 17
 - 2.07 Frontage Improvements 17
 - 2.08 Downtown Frontage Improvements..... 18
 - 2.09 Dedication of Right-of-Way..... 21
 - 2.10 Pavement Cut Moratorium 21
- Chapter 3: Street Classification 22
 - 3.01 Public Roads 22
 - 3.02 Private Roads 22
 - 3.03 Alternative Road Designs 23
- Chapter 4: Construction Control and Inspection..... 24
 - 4.01 Basis for Control of the Work..... 24
 - 4.02 Inspection..... 24
 - 4.03 Substantial Completion Approval 25
 - 4.04 Final Construction Approval..... 26

4.05	Penalties for Failure to Notify and Obtain Approval.....	27
4.06	Control of Materials	27
4.07	Construction Control in Developments	28
4.08	Sub-grade	28
4.09	Traffic Control During Construction.....	28
4.10	Call Before You Dig.....	30
4.11	Utility Certification	30
4.12	Final Cleanup and Restoration	30
Chapter 5: Private Roads, Driveway, and Parking Design		32
5.01	General.....	32
5.02	State Highways.....	32
5.03	Private Roads	33
5.04	Driveways and Driveway Approaches.....	35
5.05	Parking	38
Chapter 6: Road Design		40
6.01	Reconstruction	40
6.02	Applicable Standards	40
6.03	Typical Road Cross Sections	40
6.04	Typical Sections for Single Family Residential Access Roads.....	40
6.05	Typical Sections for Commercial, Industrial, Townhome & Multi-Family Access Roads	41
6.06	Stopping Sight Distance	44
6.07	Entering Sight Distance	45
6.08	Horizontal Curve Criteria.....	45
6.09	Vertical Alignment	46
6.10	Street Ends	46
6.11	Access and Circulation	47
6.12	Traffic Calming and Safety Treatments.....	48
6.13	Alternative Road Design Guidelines.....	49
Chapter 7: Intersection Design		51
7.01	Alignment.....	51
7.02	Spacing	51
7.03	Design Vehicles	51
7.04	Curb Radii.....	52
7.05	Drainage	52
7.06	Intersection Grades.....	53

7.07	Pedestrian Treatments.....	53
7.08	Sight Distance.....	53
7.09	Bicycle Accommodations	53
Chapter 8: Roadside Features		54
8.01	Sidewalks.....	54
8.02	Curb & Gutters	55
8.03	Construction of Curbs, Gutters, and Sidewalks	55
8.04	Expansion Joints and Sidewalk Finishing	55
8.05	Curb Ramps.....	56
8.06	Concrete Steps and Barrier-Free Access Ramps – Private Property.....	57
8.07	Shoulders	58
8.08	Bicycle Facilities	58
8.09	Fixed Objects.....	58
8.10	Amenity Zone.....	59
8.11	Illumination	59
8.12	Landscaping.....	60
8.13	Mailboxes.....	61
8.14	Cut and Fill Slopes	61
8.15	Guardrail	62
8.16	Sidewalk Side Slopes	62
8.17	Road Signs	62
8.18	Survey Monuments.....	63
Chapter 9: Surface Treatments		64
9.01	Local Public and Private Roads.....	64
9.02	Arterial, Collector, and Industrial/Commercial Roads	64
9.03	Requirements for Roads on Poor Subgrade.....	65
9.04	Road Widening.....	65
9.05	Overlays	66
9.06	Materials and Lay-Down Procedures	67
9.07	Asphalt Surfacing Repairs	67
9.08	Pavement Markings, Markers, and Pavement Tapers	68
9.09	Curb Painting.....	69
Chapter 10: Drainage.....		69
10.01	General.....	69
10.02	Road Ditches	70

10.03	Storm Sewers and Culverts	70
10.04	Catch Basin Locations and Junctions	71
10.05	Frames, Grates, and Covers	71
10.06	Erosion and Sediment Control	72
10.07	Underground Structures	72
10.08	Low Impact Development.....	73
Chapter 11:	Utilities.....	74
11.01	General.....	74
11.02	Utility Locates.....	75
11.03	Standard Utility Locations within the Right-of-Way	75
11.04	Underground Installations	76
11.05	Inspection & Notification	78
11.06	Final Adjustments	78
11.07	Microtrenching.....	79

[Appendix A – Road Classifications](#)

[Appendix B – Typical Road Sections](#)

[Appendix C – Street Tree List](#)

[Appendix D – Standard Plan Notes for Engineering Drawings](#)

[Appendix E – City of Kenmore Standard Details](#)

[Appendix F – Amendments to the Surface Water Design Manual](#)

[Appendix G – Traffic Impact Analysis Guidelines](#)

Introduction

The City of Kenmore strives to create a safe and efficient network of multi-modal transportation throughout the City which serves the needs of its residents and businesses. The City seeks to balance the needs of pedestrians, bicyclists, transit users, freight vehicles, emergency services, and drivers of personal vehicles to create a vibrant and mobile community. The City is conscious of long-term maintenance needs and must pair future *development* with a sustainable maintenance program for public improvements. The City seeks to develop in a manner which provides comfort and aesthetic value to our community while also maintaining a safe and efficient transportation network. The *Standards* provided in the following document, along with the companion documents listed within these Road Standards, are intended to ensure that future improvements are planned, designed, constructed, and maintained in a manner which best meets these City goals and best serves the needs of our community.

The City's permitting and licensing activities require the adoption of specific identifiable standards to guide private individuals and private/public entities in the administrative process of procuring the necessary City approval. The City recognizes the need to retain the flexibility to carry out its general duty to provide facilities, *walkways*, *roads*, and highways for the diverse and changing needs of the traveling public. These Road Standards are not intended to represent the legal standard by which the City's duty to the traveling public is to be measured, but a standard of design which is flexible to context-sensitive solutions where reasonable and expected care for the safety and mobility of the traveling public can be provided.

Chapter 1: Overview

1.01 Introduction

These City of Kenmore Road Standards, hereafter known as “*Standards*”, are intended to support the City of Kenmore’s goals for providing adequate facilities for *development* and growth in an efficient and effective manner, complying with storm water management regulations and preserving environmental and cultural resources while balancing these goals with the general safety and mobility needs of the traveling public.

These *Standards* cannot provide for all situations. They are intended to assist, but not to substitute for, competent work by design professionals. It is expected that land surveyors, engineers, architects, and *Contractors* will bring to each project the best of skills from their respective area of expertise. These *Standards* are not intended to limit unreasonably any innovative or creative design efforts or the design of lower impact development alternatives that could result in an equivalent or improved level of safety, mobility, quality, and maintainability. Environmental, topographical, and safety constraints as well as existing infrastructure may require more intense or rigorous design parameters than would be otherwise required. However, any proposed departure from the *Standards* will be evaluated on whether such variance will produce a compensating or comparable result that is safe and adequate.

Where errors, omissions, or conflicts occur, the *city engineer* shall provide specific interpretation and guidance which may determine that administrative corrections, additional clarifications, or supplemental information to this document are needed. Any written interpretations, corrections, clarifications, or supplemental information shall be incorporated and considered a part of this document.

1.02 Definitions, Acronyms, and Abbreviations

The definitions of term within the *Standards* shall generally be the same as those listed in the Kenmore Municipal Code except as noted below. Definitions of terms within companion documents shall be as defined within the specific documents being referenced unless otherwise noted herein.

- A. **AASHTO** - [American Association of State Highway and Transportation Officials](#)
- B. **ADA** – [Americans with Disabilities Act](#)
- C. **ADA Standard Guidelines** – For construction or alterations of *roadways* and *sidewalks* within the public *right-of-way* and/or public easements, *ADA Standard Guidelines* shall be the *Public Rights-of-Way Accessibility Guidelines* (PROWAG) published by the [United States Access Board](#). For construction or alterations on private property and private *roadways*, *ADA Standard Guidelines* shall be the most recent edition of the *Americans with Disabilities Act Accessibility Guidelines (ADAAG)* published by the United States Access Board.
- D. **Amenity Zone** – Strip of area between the back of curb and *sidewalk* which provides a buffer between pedestrians and vehicles and allows room for roadside features to be installed without obstructing accessible routes. Roadside features, such as landscaping, street lights, hydrants, mailboxes, street signage and other above ground elements may be contained within *amenity zones*.
- E. **Applicant** – Shall be any person or company who files an application for a permit from the City of Kenmore and who is either the owner of the land on which that proposed activity would be located, a *contract purchaser*, a *utility company*, or the authorized agent of such a person and shall include any such person who performs work which requires, or required, a permit from the City of Kenmore regardless of whether the permit was actually filed.
- F. **CIP** – The City of Kenmore’s Capital Improvement Program
- G. **City Engineer**– Shall mean the City of Kenmore City Engineer or designee.

- H. **City project(s)** – Shall mean any work performed by the City (either with city personnel or by way of *contract*) including but not limited to capital projects, maintenance, or repair/restoration activities.
- I. **Contract** – As identified in the *WSDOT* Standard Specifications, shall be interchangeable with “Permit”.
- J. **Contracting Agency**: Within the *WSDOT* Standard Specifications, “*Contracting agency*” shall be replaced with “The City of Kenmore”.
- K. **Contractor** – For all non-City work, shall be interchangeable with “*Applicant*” within these *Standards*. For City work, the *Contractor* shall be the person or entity contracted directly with the City for construction of improvements or maintenance, or its designee.
- L. **Developer** – Shall be interchangeable with “*Applicant*” within these *Standards*.
- M. **Development** – Means any activity upon public and private land and the *right-of-way* consisting of construction or alteration of structures, earth movement, dredging, dumping, grading, filling, mining, removal of any sand, gravel, or minerals, driving of piles, drilling operations, bulkheading, clearing of vegetation, placing concrete, paving, pavement markings, trenching or other land disturbance. Development includes the storage or use of equipment or materials inconsistent with the existing use. Development also includes approvals issued by the City that bind land to specific patterns of use, including, but not limited to, subdivisions, short subdivisions, zone changes, conditional use permits, and binding site plans. Development does not include the following activities: 1) Interior building improvements; 2) exterior structure maintenance and restoration activities (including painting and roofing); 3) Routine landscape maintenance of established landscaping, such as lawn mowing, pruning and weeding, including replacement of existing plants; 4) routine maintenance of public facilities located within a *road*; or 5) maintenance of the following existing facilities that does not expand the affected area: septic tanks (routine cleaning), wells, individual *utility* service connections on private property, and individual cemetery plots in established and approved cemeteries.
- N. **Development Engineer**—As defined in *KMC* 17.10
- O. **DOE** – [Washington State Department of Ecology](#)
- P. **Driveway** – Onsite parking space for *single family* and *townhome* residential structures and on-site access *roads* to parking lots on private property.
- Q. **Driveway Approach** – Access point from any *road* to a *driveway*, garage, carport, private *road*, or alleyway, typically from the *roadway* to the back of *sidewalk* (*right-of-way*/tract line if no *sidewalk*).
- R. **FHWA** – United States Department of Transportation Federal Highway Administration
- S. **Groundwater** – Water in a saturated zone or stratum beneath the land surface or a surface waterbody. Groundwater may also be flow which moves laterally beneath the visible surface of an area and which may or may not eventually spring to the surface to create a new source of *surface water*.
- T. **HMA** – Hot Mixed Asphalt
- U. **IES** – Illuminating Engineering Society of North America
- V. **Inspector** – Unless otherwise noted, shall be the City of Kenmore staff or designee(s) assigned to observe construction and authorized as noted in Chapter 4 to approve and/or reject work under these *Standards*.
- W. **KCRS** – [King County Road Design and Construction Standards](#)
- X. **KMC** – [Kenmore Municipal Code](#)
- Y. **KSD** - City of Kenmore Standard Details
- Z. **Licensed PE (xxx)** - Professional civil engineer licensed in the State of Washington. (xxx) represents any specific license other than general Civil Engineering.
- AA. **Low Impact Development (LID)** - Shall mean *stormwater* and land use management strategy that strives to mimic predisturbance hydrologic processes of infiltration, filtration, storage, evaporation and transpiration by emphasizing conservation, use of on-site natural features, site planning, and distributed *stormwater*

management practices that are integrated into a project design. Other common names for “LID” are “green stormwater infrastructure” or “natural drainage systems.”

- BB. **Multi-Family** – Per *KMC* 18.20.835 and shall include duplexes, triplexes, mobile home parks, and condominiums
- CC. **MUTCD** - [Manual on Uniform Traffic Control Devices](#)
- DD. **NACTO** - [National Association of City Transportation Officials](#)
- EE. **Off-Site**– Shall mean any area not within the public *right-of-way* or public easement.
- FF. **Project Frontage/Frontage** – Shall mean all areas within the public *right-of-way* (developed or otherwise) that are directly adjacent to a given parcel extending out to the centerline of the *right-of-way* as required by these *Standards*.
- GG. **RCW** – [Revised Code of Washington](#)
- HH. **Right-of-Way** – Areas dedicated for the use of public travel and other secondary *road* purposes such as *utilities*. Permanent easements and tracts dedicated for public use and other secondary *road* purposes shall be considered as “*right-of-way*”. *Right-of-way* boundaries are generally defined by adjacent private property lines except where easements are in place.
- II. **Road** – Public: The full width of the *right-of-way* boundary lines including permanent easements obtained for public use (same as Highway as defined by *RCW* 46.04.197 and City Street as defined in 36.75.010). Private: The full width of the tract boundary including any permanent easements for public or *utility* use. *Roads* shall include all *roadways*, *walkways*, *utilities*, landscaping, unimproved areas and surrounding improvements in support of said *roadways*, *walkways* and *utilities*.
- JJ. **Roadway** – Shall mean all asphalt/concrete/gravel improvements designated for vehicular *traffic*. Improvements shall include subsurface backfill, pavement markings and other markings, *shoulders*, bike lanes, edgework (such as slopes, walls, and barriers meant to support the *roadway*), guardrails, street lighting, curb and gutter (when not installed for *sidewalk* purposes), crosswalks, medians (including pavement/pavers, landscaping, and other aesthetic improvements), and *traffic* calming devices.
- KK. **Sharrow (Shared Lane Marking)** – A pavement marking within a vehicle travel way which alerts drivers to expect shared lane use with bicycles and serves as bicycle facility wayfinding and position guidance for bicyclists; typically depicted by a bicycle and two chevrons or arrows pointing in the direction of travel.
- LL. **Shoulder** – The paved or gravel area between the edge of travel lane (including bike lane, if applicable) and the curb or *right-of-way* line where no curb exists.
- MM. **Sidewalk** – Shall mean a formal pedestrian path which is elevated above, or separated from the vehicle travel way, except where otherwise noted. Sidewalk shall also include curb ramps, transition ramps, curb and gutter (when installed for sidewalk purposes), pedestrian lighting, and any other feature necessary to comply with the *ADA* when not addressed specifically.
- NN. **Single Family** – Same as Single Detached Dwelling Unit per *KMC* 18.20.840 (a detached building containing one dwelling unit or an adult family home).
- OO. **Standards** – Shall mean the requirements listed in this document or within the companion documents listed below, or any portion thereof.
- PP. **Street** – Same as *Road*
- QQ. **Street End (Dead-End)**- Any *roadway* that has a single connection point to a public *roadway* without a circulation pattern that requires a cul-de-sac or hammerhead.
- RR. **Stormwater** – Shall mean the water produced during precipitation or snowmelt, which runs off, soaks into the ground, or is dissipated through evapotranspiration. Stormwater that runs off or soaks into the ground ultimately becomes *surface water* or *groundwater*.

- SS. **Surface Water** – Shall mean water flowing on the surface of any area as a direct result of rainfall on or adjacent to the area; for the sake of these *Standards*, ground water that has not broken the surface shall not be considered as surface water.
- TT. **Townhouse/Townhome** – Same as *KMC* 18.20.835 (A one-family, ground-related dwelling attached to one or more such units or to a nonresidential use in which each unit has its own exterior, ground-level access to the outside, no unit is located over another unit, and each unit is separated from any other unit by one or more vertical common walls).
- UU. **Traffic** – The movement of vehicles, pedestrians, bicycles and other modes of transport.
- VV. **Undeveloped Property or Undeveloped Parcel** - Shall be any parcel which has not been subdivided to the maximum potential per the minimum lots size permitted in *KMC*, or which is zoned to permit a *single family* residential, commercial, *townhome*, or *Multi-Family* structure which has not been constructed, or any parcel without any structures or *utilities*.
- WW. **Utility** – Shall mean storm drainage, power, gas, telecommunication, fiber optic, cable, water, and sewer systems.
- XX. **WAC** – [Washington Administrative Code](#)
- YY. **Walkway** – Shall mean any surface, path, or route which is regularly used by pedestrians; walkways may include *sidewalks*, paved and un-paved trails, worn foot trails, boardwalks, and paved and unpaved *shoulders*. Existing walkways may include facilities in which the vehicles and pedestrians utilize the same travel way.
- ZZ. **WDFW** – [Washington State Department of Fish & Wildlife](#)
- AAA. **WSDOT** – [Washington State Department of Transportation](#)

1.03 Companion Documents

These *Standards* reference additional documents for specific information on details, materials, and construction guidance and may be utilized when standards of other design criteria are not specifically addressed in this document. The following documents shall be incorporated by reference; future updates to the referenced documents shall be incorporated into these *Standards* upon the effective date of said documents without need for further action. Where updates to referenced information causes the references to become obsolete or no longer reference the intended information, the *city engineer* shall be authorized to interpret the intent of the updated reference or determine the most appropriate reference to use. The documents are listed in descending order of precedent for each section (A-D). Bullet 1 will take precedence over bullet 2, bullet 2 will take precedence over bullet 3, etc.

- A. Transportation Design Standards
 - 1. *City of Kenmore Standard Details (KSD)*, current edition
 - 2. United States Access Board *ADA Accessibility Standards and Public Rights-of-Way Accessibility Guidelines 2011*
 - 3. *King County Department of Transportation Road Design and Construction Standards (KCRS)*, current edition
 - 4. *Northshore Fire Department Standards, Chapter 2.00 Access and Addressing*, current edition
 - 5. *Urban Street Design Guide*, National Association of City Transportation Officials (*NACTO*), current edition
 - 6. *WSDOT Standard Specifications for Road, Bridge, and Municipal Construction* (herein referred to as ‘*WSDOT Standard Specifications*’), current edition
 - 7. *WSDOT Standard Plans*, current edition
 - 8. *AASHTO Policy on Geometric Design of Highways and Streets* (herein reference as *AASHTO*), current edition
 - 9. *WSDOT Design Manual*, current edition
 - 10. *City of Kenmore Traffic Calming Program Policies and Procedures*, current edition

11. *AASHTO Highway Safety Manual, current edition*
- B. Surface Water Design Standards
 1. *City of Kenmore Standard Details (KSD), current edition*
 2. *King County Surface Water Design Manual (SWDM)*
 3. *WA State Department of Ecology Stormwater Management Manual for Western Washington, current edition*
 4. *WSDOT Highway Runoff Manual, M31-16.01, current edition*
 5. *Low Impact Development Technical Guidance Manual for Puget Sound, current edition*
- C. Traffic Control Design Standards:
 1. *FHWA Manual on Uniform Traffic Control Devices (MUTCD), current edition*
- D. Construction Specifications:
 1. Project specific specifications (for *City projects* only)
 2. *City of Kenmore Standard Details (KSD), current edition*
 3. *WSDOT Standard Specifications for Road, Bridge, and Municipal Construction* (herein referred to as ‘*WSDOT Standard Specifications*’), current edition
 4. *King County Road Design and Construction Standards* (herein referred to as *KCRS*), current version

1.04 Variances

Variances from these *Standards* may be granted per the procedures outlined in *KMC 12.50.060*.

Variances may be administratively appealed. Appeals on a variance decision shall be received by the City no later than 30-days after the decision or within 30-days of an official public noticing as part of a SEPA or Land Use decision (if applicable), whichever is later. Appeals received after this time shall not be considered. To be considered, appeals must contain the following information:

- Project name and location
- Variance number and description
- Statement of reconsideration
- Justification for reconsideration
- Supporting documentation
- Contact information

Completed appeal packets will be reviewed by the *city engineer*. Decisions made on appeals will be final; no other appeals will be accepted.

City projects are exempt from the formal variance process. Variance approvals by the *city engineer* shall be in writing or via signature on the City’s plan set.

If a Standard requirement is immediately followed by “unless otherwise approved by the *city engineer*”, an informal approval process is acceptable; no formal road variance is required.

1.05 Applicability

These *Standards* shall be applicable to all *developments*, new construction and alterations, as outlined in *KMC 12.50.030*.

1.06 Authority and Duty of Inspectors

The City may designate *inspectors* to inspect all materials used and all work performed. Such inspection may extend to any or all parts of the work and to the preparation and/or manufacture of the materials to be used. All *roadway*, *sidewalk*, and *utility* infrastructures must be inspected. Paving and concrete operations and *road* backfills shall not commence until material testing has been completed. Subsequent lifts of material shall not commence until density tests confirm that the compaction is in accordance with the specifications.

- A. The *inspector* will not be authorized to revise, alter, or relax the provisions of these *Standards* without prior approval by the *city engineer*.
- B. The *inspector* has the authority to reject defective material and/or reject/suspend work that is not in conformance with these *Standards* or any approved permit or variance.
- C. The *inspector* may advise the *applicant* or *contractor* of any faulty work or materials at any time; however, failure of the *inspector* to advise the *applicant* or *contractor* does not constitute acceptance or approval.
- D. The *inspector* has the authority to require revisions to approved engineering plans within the dictates of these *Standards* when necessary due to conflicting field conditions.
- E. Unless otherwise addressed in a *contract* directly between the *Contractor* and the City of Kenmore, the City accepts no responsibility for costs, delays, or loss of profits incurred by the *Developer*, *Contractor*, or any of their representatives, as a result of improper work, improper materials, conflicting field conditions, or any direction provided by the City *inspector* which is consistent with these *Standards*. It shall be the responsibility of the *Contractor* to verify all field conditions and all information provided, including information provided by the City, prior to beginning construction.

1.07 Cultural Resources

All impacts to any cultural resources shall be avoided to the maximum extent feasible. For projects sites which are, or contain, an archaeological or cultural resource as defined in [RCW 27.53](#), shall follow the rules and procedures prescribed by the state and shall obtain a permit as required per [RCW 27.53.060](#). If archaeological or cultural resources are discovered, all work on the site shall be suspended until evidence of the required permits are provided to the City or until alternative direction is provided in writing to the City from the proper state agency.

1.08 Permits

Permits issued by the City of Kenmore are required for all improvements, alterations, or maintenance within the public *right-of-way* and as required by *KMC* Title 20 unless otherwise noted within these *Standards*.

- A. It is the responsibility of the *Developer/Contractor* to verify from the City which permits are required for any given project.
- B. Other permits in environmentally sensitive areas and/or buffers may be required from other agencies. It is the responsibility of the *Developer/Contractor* to determine what, if any, other permits are required. All other permits obtained shall be provided to the City for review.
- C. City of Kenmore Capital Improvement Projects within the *right-of-way* are exempt from obtaining City permits (e.g. Engineering, Right of Way, etc.). This does not exempt projects from SEPA or other Land Use applications. Any work performed on property outside of the *right-of-way* (excluding permanent easements) shall require review by the *Development Services* Department to determine if additional City permits are required.

1.09 Engineering Plans, Final Corrected Plans, and Final Plat Plans

Engineering plans for private *development* proposals shall be prepared and submitted to the City. The engineering plans

shall be prepared by a Licensed PE and must be signed and stamped by the responsible professional engineer prior to issuing any permit.

A. Engineering Plan Requirements:

1. The engineering plans for *surface water* design shall generally comply with Chapter 2 of SWDM, including minimum plan size, minimum scale, vertical and horizontal datum, and general content. The City may require supplemental plan elements in addition to those listed in SWDM.
2. Engineering plans for *roadway* and site design shall contain all necessary information to determine what is proposed including a vicinity map, 1:30 or 1:20 scale (full size), vertical (NAVD88) and horizontal (NAD83/91) datum, designer name and address, project address, project name, and City provided project number. The follow plans sheets are required as applicable (work may be combined onto single sheets if clear and easily read):
 - i. Cover Page
 - ii. Existing Site conditions (including *utilities*)
 - iii. TESC Plan
 - iv. Grading Plan
 - v. Drainage Plan
 - vi. Structural sheets (if applicable)
 - vii. *Utility* Plan
 - viii. Traffic Control Plan
 - ix. Civil (paving, *sidewalk*, curb, gutter, etc.) Plan
 - x. Landscaping Plan
 - xi. Channelization Plan
 - xii. Associated cross sections
3. All engineering plans shall incorporate the City's Standard Plan Notes in the appendix as amended and approved by the *Development engineer*.

B. Waiver of Plan Requirements: Subject to review, the *city engineer* may waive plan requirements, wholly or in part, based on the following criteria:

1. No more than 2,000 square feet will be cleared and graded; and
2. The work will not intercept a stream, wetland, or sensitive area buffer, or otherwise impact sensitive areas and natural surface drainage as set forth in *KMC* Title 18; and
3. Work will not impact the storm drainage system; and
4. Plans do not include a retention/detention facility; and
5. Kenmore standard drawings, submitted with required permits, are sufficient to describe the improvement to be constructed; and
6. No more than 500 square feet of new impervious surfacing will be added; and
7. No new *sidewalks*.

C. Record Drawings:

1. Record drawings, or as-built drawings, for archiving shall be required prior to final construction approval for all projects which include improvements within the public *right-of-way* or improvements that will be maintained or routinely inspected by the City.
2. Record drawings shall include as-built information for all improvements within the public *right-of-way* or improvements that will be maintained or routinely inspected by the City and shall be of similar detail as

the original design plans.

3. Record drawings shall measure and document all elevations, slopes, and dimensions associated with all new *sidewalks* including all *ADA* facilities. Any portion of the *sidewalk* or facilities which does not meet *ADA* requirements shall be removed and replaced with a compliant feature unless justified in Maximum Extent Feasible/Practical (MEF) documentation provided by the *Applicant*. The MEF documentation must be prepared and stamped by a Licensed PE and must be approved by the *city engineer*.
 4. Record drawings shall be reviewed and approved by the City prior to final submittal. Review sets shall be submitted electronically.
 5. Final submittal of the record drawings shall be submitted electronically in AutoCAD format (version 2016) and in pdf format unless otherwise approved by the *city engineer*.
- D. Maintenance Plans: Maintenance plans may be required for specialized features. Engineering plans shall be reviewed to ensure that all *road* elements proposed for public maintenance will be maintainable by the City.
1. For purposes of public maintenance, a maximum reach of 16 feet by a backhoe type bucket shall be assumed.
 2. For the purposes of public maintenance, a maximum boom reach of 18 feet, measured horizontally from the nearest edge of the access *road*, for a hydraulic vactor truck shall be assumed.

1.10 Errors and Omissions

At the discretion of the *city engineer*, any errors or omissions in the approved plans or information used as a basis for such approvals may constitute grounds for withdrawal of the approvals and/or stoppage of any or all permitted work. It shall be the responsibility of the *Applicant*, *Developer*, or *Contractor* to show cause for why such work should continue and make such changes in plans that may be required by the *city engineer* before the plans are re-approved.

It is the responsibility of the *Applicant* to verify property and *right-of-way* lines and the location of *utilities* prior to and during construction. Under no circumstances is the City responsible for verification of property lines or *utilities*. Approval of installed improvements does not guarantee that the improvements are installed on the property permitted or that *utility* conflicts do not exist and does not relieve the *Applicant* of the civil duty or responsibility to correct such errors after becoming aware of the conflict.

1.11 Penalties and Financial Guarantees

Failure to comply with these *Standards* will be cause for denial of permit approval, revocation of prior approvals, withholding of financial guarantees, withholding final inspection approval, withholding occupancy certificates (temporary and permanent), legal action for forfeiture of financial guarantee, code enforcement, and/or other penalties as provided by law.

- A. PERFORMANCE/RESTORATION FINANCIAL GUARANTEES: Any construction work on City *right-of-way* (both maintained and unmaintained) which is not performed by the City of Kenmore or its representatives shall be guaranteed by a restoration financial guarantee unless otherwise approved by the *city engineer* or waived per *KMC* Title 21.15.060. The *Development engineer* shall determine the amount and form of the financial guarantee. The minimum restoration and/or performance guarantee shall be \$2,000.00.
- B. MAINTENANCE/DEFECT GUARANTEES: The successful performance of the *right-of-way* improvements or related drainage facilities shall be guaranteed for a period of at least two years from the date of Final Construction Approval, unless otherwise determined by the *city engineer* or as directed in Kenmore Municipal Code. Any repair or replacement of defective work/material may require an extension of the guarantee an additional two years or until such time as the *city engineer* deems appropriate. The *Development engineer* shall determine the amount and form of the maintenance financial guarantee. The minimum maintenance guarantee shall be \$2,000.00.

Any changes of property ownership will require new financial guarantee(s) submitted by the new owner equal in value to the original guarantee(s). New financial guarantee(s) shall assume all responsibility for previous and new work and no liability will be carried by the previous owner's guarantee(s). Transfer of permit(s) to new owners/*developers* will not occur until new financial guarantees are received and accepted by the City.

1.12 Changes to the Road Standards

The *city engineer* may incorporate changes to these *Standards* as they become necessary and may determine the severity of any future proposed revisions. Minor changes (grammatical, spelling, code reference changes, formatting, etc.), updates to the Companion Documents, or revisions to the documents in the appendices may be administratively approved and incorporated into the *Standards*.

Developments submitted for permits shall be vested to the *Standards* in effect at the time of a completed initial permit application. Revisions to a permit application with substantial changes per *KMC* 17.20.030 and 17.20.060 shall be considered an "initial" permit application. Changes made due to regulatory changes, safety issues, or environmental concerns may require the *Applicant* to comply with those revised sections of the *Standards*.

Chapter 2: General Requirements

2.01 Responsibility to Provide Frontage Improvements

All *developments* shall make *road* improvements in accordance with these *Standards*. Additional *road* improvements on private property and/or the *right-of-way* may be required based on an assessment of the impacts of the proposed land *development* by the *Development engineer*.

- A. Frontage requirements per Section 2.07 for a subdivision or short subdivision shall be based upon the original parcel size prior to subdividing.
- B. A *development* project that is adjacent to a current or proposed *CIP* project will be required to construct the frontage improvements per these *Standards*; fee in lieu may be required at the discretion of the *city engineer* (see Section 2.02).
- C. Any *development* abutting or accessing existing public *roads*, including but not limited to new single-family homes, subdivisions, and commercial or *townhome/multi-family* projects, shall improve the frontage of those *roads* in accordance with these *Standards*.
 1. On lots which develop behind another parcel or parcels abutting the *roadway* and utilize a tract, alleyway, private *road*, easement or other access stem to access the *right-of-way*, the project frontage shall be the segment of *roadway* equal to the widest portion of the *development* parcel. Where the required improvements cannot be installed due to limited or restricted *right-of-way* along adjacent properties, the *Applicant* may be required to pay a fee in lieu consistent with Section 2.02.
 2. In the case of corner lots, frontage improvements are required on both *street* frontages.
 3. In the case where a lot has two non-adjointing frontages (i.e. not a corner lot), frontage improvements are required on any frontage which will provide access to any existing or new lot and/or structure. Frontage improvement will be required on any *road* which is classified as an arterial or collector, regardless if access is taken off of the *road*.
- D. Any *development* that contains internal *roads* or requires the construction of new *roads* to provide access to the proposed lots, structures, or service areas shall construct or improve those *roads* in accordance with these *Standards*.
- E. Subdivisions, short subdivisions, binding site plans or any other land *development* project which is subject to recording shall not be recorded until there is a recorded continuous paved public access to the *development* site.
- F. All new and altered *roads* shall provide applicable pedestrian and bicycle improvements that meet the *Standards*.
- G. Alterations to the existing frontage improvements will require that the frontage be constructed per these *Standards*. Maintenance or repair efforts matching existing will not require upgrading to these *Standards* unless otherwise directed by the *city engineer*.
- H. Additional *sidewalks* may be required where alternative pedestrian access provides better connections to existing public facilities or may be required beyond the existing property lines to provide pedestrian connections to existing *sidewalks*. The following conditions may require alternative or additional *sidewalk* connections:
 1. A shorter distance or more favorable terrain than *sidewalk* along an existing or proposed *road* exists, or
 2. Where pedestrian facilities exist along the existing *road* that are within 50 feet of the property lines.
- I. Adaptive re-use projects, which involve sites or buildings identified as a Local Landmark per *KMC* Chapter 2.20, a King County Landmark per the King County Historic Preservation Program, or an Historic Place per the National Register of Historic Places, shall not be required to provide improvements that fully comply with the requirements of this Section; provided that:
 1. All projects must still provide safe and *ADA* accessibility for all users as determined by the *city engineer*.

2. Projects which include new buildings or expansion of an existing building shall not be considered an ‘adaptive re-use project’ within the *Standards*.
- J. Recognizing that the City is a partially built environment which was developed under several different requirements, the *city engineer* may modify the frontage improvement and/or fee-in-lieu requirements in other situations where service level, safety, or operational efficiency of the *roads* serving a site will be affected. Additional requirements will consider constitutional provisions, statutory provisions and court case principles, City planning, existing *right-of-way* conditions in front of and adjacent to the *development* as well as the *development* proposal and the conditions of existing site, buildings, and/or adjacent property.
 - K. The following types of *development* projects are exempt from providing frontage improvements:
 1. Alterations or additions to an existing single-family home. An alteration or addition is defined as all changes made to an existing structure within a 5-year period that result in a cost less than 50% of the taxable improvements value of the existing structure as determined by the most current King County Department of Assessments.
 2. *Single family* projects which reconstruct a previously existing single-family home that was demolished within 12 months of the date of an approved new building permit are not required to construct frontage improvements on local *roads* only.
 3. Alteration projects on existing commercial or industrial structures within a 5-year period that result in a cost less than 50% of the taxable improvements value of the existing structure as determined by the most current King County Department of Assessments and which do not expand or change the use on site.
 4. Accessory Dwelling Unit (ADU) projects as defined by *KMC* 18.20 and 18.73.
 5. At the discretion of the *city engineer*, *City projects* may be granted an exemption from frontage improvements.

2.02 Fee in Lieu Option

Applicants of *developments* which require frontage improvements per Section 2.01 may request to pay a fee in lieu of providing frontage improvements, or any portions of those improvements, to be granted at the discretion of the *city engineer*.

The City, at its discretion, may require a fee in lieu of improvements at locations where new *sidewalk* will not provide a significant public value (as determined by the City), where shared spaces are desired, or where a future *CIP* may be proposed. The City may also, at its discretion, require a fee in lieu of pavement improvements at locations where the pavement rating condition is rated as “good” or better (PCI > than 80) based upon the City’s current Pavement Management System. A fee in lieu cost for pavement overlay shall be based upon the square foot cost of the City’s most recent asphalt overlay project taking into account the design, construction and inspection of the City’s project.

If a *City project* has constructed the frontage improvements to these *Standards*, the *Applicant* shall pay a fee in lieu for said frontage improvements if a permit application is submitted within 2 years of the substantial completion of the *City project*.

The fee in lieu cost shall be based on the total length of the project frontage along public *roads* and the cost estimates used by the City in the most current update of the City’s Pedestrian Facilities Plan. The City reserves the right to deny any request where the physical improvements would be of greater public value than the fee in lieu fee.

2.03 Low Impact Development

Low Impact Development (*LID*) best management practices are the preferred and commonly used approach to site *development* and are required to be used whenever feasible in land and frontage improvements as directed in *KMC* and as defined by the *SWDM* and the *city engineer*. Where these *Standards* present barriers to the use of *LID* best

management practices a variance to these *Standards* may be considered, provided that the variance does not violate other sections of *KMC* and is adequately designed for safety, *ADA* accessibility, functionality, and maintenance concerns.

2.04 Maintenance

The City will not accept any improvements for maintenance until the improvements have been approved by the Public Works Department and all performance agreements associated with the improvements have been released by the City. Until the City has accepted the improvements for maintenance, the project *Applicant* shall be responsible for the condition, function, safety, security, and general maintenance of all *roadways* or improvements.

- A. Only improvements within the *right-of-way*, or expressly approved by the City in a recorded document on file with the King County Recorder's Office, will be accepted for City maintenance.
- B. Easements not expressly dedicated to the City are to be interpreted as private easements which do not assign a maintenance responsibility to the City of Kenmore.
- C. Easements which grant the City of Kenmore the right of entry for the purposes of inspection shall include language that specifically assigns the right of inspection, but not necessarily the responsibility to inspect the improvements within said easement. The City is not responsible for any costs which are associated with the improvements within these types of easements, including cost associated with inadequate maintenance.

2.05 Connectivity

Proposed *roadway* layouts shall continue *roads* to adjacent properties when the adjacent property is an *undeveloped parcel* or has reasonable chance of *re-development* in the future. This requirement may include additional *right-of-way* dedication beyond constructed limits necessary to provide for future *roadway* connections.

- A. To the maximum extent feasible, connections shall be located at the anticipated or logical location which maximizes the *development* potential of the adjacent parcel.
- B. Pedestrian *walkways* shall be required to connect *roadways* where construction of full *roadway* improvements is not feasible to provide connectivity for vehicles. Pedestrian *walkways* shall be provided to create the shortest route between *development* and existing *walkways*, independent of *roadway* improvements.

2.06 Traffic Impact Analyses

A traffic impact analysis shall be required per *KMC* 17.20.070 and 12.85.050 when applicable. A traffic impact analysis shall also be required if, as determined by the City, the proposed *development* could potentially create a significant impact to *traffic* operations. The traffic impact analysis shall be completed in accordance with the administrative policies and guidelines identified in Appendix G.

2.07 Frontage Improvements

Frontage improvements shall require bringing half of the frontage *road* to the requirements for the *roadway* classification per these *Standards*. Existing frontage improvements shall be upgraded to these *Standards*.

- A. Standard frontage improvements consist of *road* widening, *right-of-way* dedication, new curb & gutter, new *sidewalk*, new *Amenity Zone* and/or landscaping, drainage improvements as needed, street lighting per Section 8.11, relocation of conflicting *utilities* as needed, 2-inch half-width grind and overlay along the entire project frontage, and new pavement markings.
 - 1. Additional improvements, including transit bus shelters, bus pullouts, *utility* undergrounding, lighting, signage, and revised channelization, may be required to ensure safe movement of *traffic*, including pedestrians, bicycles, transit, and non-motorized vehicles.

2. Additional improvements may be required along SR-522 or in the downtown areas as directed in Section 2.08.
- B. Half of the frontage *road* shall mean that point measured from the center of the existing *right-of-way* to the proposed property line. Depending on existing topography and improvements, at the discretion of the *city engineer*, the half *road* measurement may be taken from the center of the existing paved *roadway*.
 - C. Any project which utilizes a zero-foot or modified setback, as permitted by *KMC*, and places a building too near to the *right-of-way* line to maintain overhead service without impacting the required *walkway* or required clear zone shall be required to underground *utilities* along the entire project frontage.
 - D. *Utility* undergrounding is required at the following locations:
 1. along SR-522
 2. in the downtown areas as directed in Section 2.08.
 3. where existing *utilities* are currently underground
 4. all new or replaced service connections

2.08 Downtown Frontage Improvements

Developments along, or which take access from, *roadways* identified in Figure 2.1 shall provide additional improvements as outlined below.

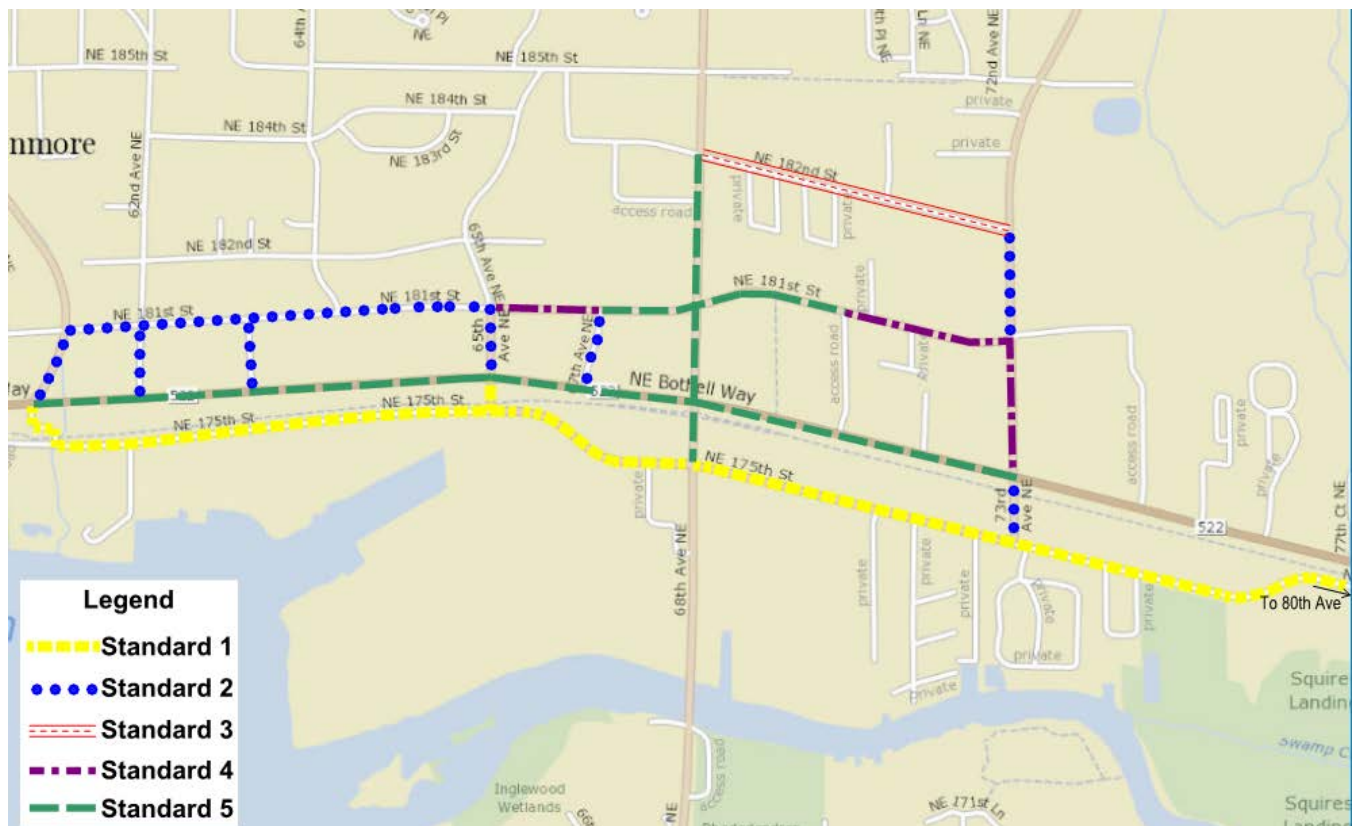

Figure 2.1: Downtown Improvements Map

	Compliance with KMC 18.52.100	Improvement Details to be Determined	Downtown Sidewalk	Downtown Street Trees with Irrigation	Electrical Receptacles at Tree Locations	Downtown Street Lighting	Streetlight Barrier Brackets	Downtown Pedestrian Lighting	Pedestrian Flower Basket Arms with Irrigation	Undergrounding of Existing Utilities
	2.08.A	2.08.B	2.08.C	2.08.D	2.08.E	2.08.F	2.08.G	2.08.H	2.08.I	2.08.J
Standard 1	X	X								X
Standard 2	X		X	X		X		X		X
Standard 3	X			X		X		X		X
Standard 4	X		X	X	X	X	X	X		X
Standard 5	X		X	X	X	X	X	X	X	X

Figure 2.2: Downtown Improvements Table

- A. All improvements along *roadways* identified on Figure 2.1, shall be consistent with direction provided in KMC 18.52.
- B. Projects along *roadways* identified in Figure 2.1 as Standard 1 shall require specialized improvements with exact details for special pavement types, architectural features, and lighting styles to be determined during project design and shall require submitting samples, cut sheets, or shop drawings to the City for approval prior to installation. Projects within this area may be required to match improvement details of other nearby projects as *developments* establish throughout this area.
- C. **Downtown Sidewalk:** Projects along *roadways* identified in Figure 2.1 as Standard 2, Standard 3, Standard 4, and/or Standard 5 shall provide a minimum 6-foot wide *sidewalk* with 4-foot wide *Amenity Zone* within the public *right-of-way* with a 2'x2' scoring pattern per KSD 8-008 and as follows:
 - 1. Lightly brushed in a transverse direction (perpendicular to *road*) with a soft brush and then a 2-foot by 2-foot grid pattern shall be saw cut into the top of the concrete surface.
 - 2. Sawcut lines shall run perpendicular and parallel to the curb line and shall intersect at 90° angles.
 - 3. Around curves and curb returns, the lines shall be adjusted as shown in KSD 8-008.
- D. **Downtown Street Trees:** Projects along *roadways* identified in Figure 2.1 as Standard 2, Standard 3, Standard 4, and/or Standard 5 shall provide *street trees*, with irrigation, placed at the back of curb.
 - 1. Tree spacing may be varied slightly to account for proper sight distance, *utility* placement, or other potential site conflicts, as approved by the City.
 - 2. Landscape areas provided for *street trees* shall not exceed 4 feet in width and shall always maintain a minimum of 6-foot *sidewalk* clearance.
 - 3. Irrigation lines shall be provided to all plants and trees. Irrigation systems shall be connected to an existing City irrigation controller or a new irrigation controller shall be provided as needed. *Applicant* shall coordinate meter placement & configuration with the water district. Irrigation materials, including controller, shall be consistent with existing City systems. Irrigation system materials and location of controller shall be coordinated with and approved by the City Public Works Department. *Applicant* shall coordinate power service for the controller with Puget Sound Energy.

4. Tree grates shall be provided for these areas if tree wells are installed.
 5. See Section 8-12 for additional requirements.
- E. **Electrical Receptacles:** Projects along *roadways* identified in Figure 2.1 as Standard 4 and/or Standard 5 shall include above-ground electrical receptacles, supplied with power, within the pervious area for *street* trees required per Section 2.08D above.
1. *Applicant* shall coordinate power service for receptacles with Puget Sound Energy.
 2. Future power costs for the electrical receptacle shall be transferred to the City upon City approval.
- F. **Downtown Roadway Lighting:** Lighting design shall be per Section 8.11. Projects along *roadways* identified in Figure 2.1 as Standard 2, Standard 3, Standard 4, and/or Standard 5 shall provide specialized *roadway* lighting as follows (or an approved equal):
1. Head Type (Model Number): Lithonia Aeris Decorative *Roadway* Led Luminaire (AS1 LED 1 63B30/40K SR 3 240 SPA DF DDBXD)
 2. Arm Type (Model Number): Lithonia Aeris Decorative Curved Arm (DCASDDBXDU)
 3. Arm length: 2 feet
 4. Mounting Height: 35 feet from bottom of luminaire (40 feet along SR-522)
 5. Color: Powder coated Bronze 50 Gloss (Pearlescent) from Cardinal Paint (TO25-BR01)

Applicant shall coordinate power service with Puget Sound Energy (PSE) and will be responsible for facilitating transferring ownership of the lighting system to PSE. *Applicant/Contractor* to facilitate transfer agreement between PSE and the City (note: agreement must be in place before PSE will energize the lighting system).

- G. **Streetlight Banner Brackets:** Projects along *roadways* identified in Figure 2.1 as Standard 4 and/or Standard 5 shall include a set of banner brackets on all street lighting required per Section 2.08.F
1. Bracket types and details shall be approved by the *city engineer* prior to installation and shall be colored to match the light pole.
 2. Brackets shall be installed on the side of the pole furthest from the *roadway*, perpendicular to the direction of travel.
 3. Bottom of bracket shall be mounted 15 feet above the finished grade.
- H. **Downtown Pedestrian Lighting:** Lighting design shall be per Section 8.11. Projects along *roadways* identified in Figure 2.1 as Standard 2, Standard 3, Standard 4, and/or Standard 5 shall provide specialized pedestrian lighting as follows (or an approved equal):
1. Head Type (Model Number): Selux Quadro H2 Led Decorative Pedestrian Luminaire (QH2L-R5-1-4LT500-30-BZ-208)
 2. Mount Height (bottom of luminaire): 14 feet
 3. Color: Powder coated Bronze Pearlescent (TO25-BR01)

Applicant shall coordinate power service with Puget Sound Energy (PSE) and will be responsible for transferring ownership of the lighting system to PSE. *Applicant/Contractor* to facilitate transfer agreement between PSE and the City (note: agreement must be in place before PSE will energize the lighting system).

- I. **Pedestrian Flower Basket Arms:** Projects along *roadways* identified in Figure 2.1 as Standard 5 shall provide a set of two mounts, arms, and irrigation for hanging flower baskets on each pedestrian light pole required per Section 2.08H.
1. The mounts shall be aligned parallel to the *roadway* on opposite sides of the pole.
 2. Irrigation must be provided to each mount arm. Irrigation sleeve to be internal to pole up to arms.
 3. Mount types and details shall be approved by the *city engineer* prior to installation and shall be colored to match the light pole.
 4. Arms shall be mounted 11 feet from finished grade.

- J. **Utility Undergrounding:** Projects along *roadways* identified in Figure 2.1 as Standard 1, Standard 2, Standard 4, and/or Standard 5 shall be required to relocate any existing overhead *utility* lines along the project frontage into underground conduits in compliance with the *utility* provider’s specifications and these *Standards*.
 - 1. Note: All new *utility* extensions are required to be undergrounded per KMC 13.50.010.

2.09 Dedication of Right-of-Way

The City may require *right-of-way* dedication to incorporate necessary transportation and frontage improvements.

- A. *Right-of-way* dedication width shall be consistent with these *Standards* except where additional *right-of-way* widths have been proposed for projects on the City’s Transportation Improvement Program, the Capital Improvement Program, the Transportation Element of the Comprehensive Plan, or as needed for *utility* services.
- B. *Right-of-way* dedication, when required, shall occur at the time of recording for subdivisions or prior to issuing the certificate of occupancy on other project types.

2.10 Pavement Cut Moratorium

No pavements cuts will be permitted on any *road* which has been constructed, re-constructed, overlaid, or resurfaced within the past 5-years from the date of permit submission, except as noted below. All reasonable effort shall be made to utilize trenchless technology for *utility* installations before an exception is granted.

- A. Pavement cuts may be approved in the following cases:
 - 1. The project includes a full-width 2-inch grind and overlay and the cuts are within the limits of the proposed overlay.
 - 2. The cut is allowed through a current franchise agreement.
 - 3. The cut is for an emergency situation, provided that a 2-inch full-width grind and overlay is provided as noted in Section 11.04F after the emergency work is completed.
- B. City capital improvement and maintenance projects are exempt from the pavement cut moratorium.

Chapter 3: Street Classification

3.01 Public Roads

City *roads* are classified functionally as noted in Appendix A. Function is the controlling element for classification and shall govern *right-of-way*, *street* width, and *street* geometrics. Functional classification establishes the hierarchy of *streets* and highways necessary for a complete transportation system that serves all types of travel needs. Each *road* has a specified function that produces a comprehensive network for travel and access throughout an area when combined with the rest of the system.

Public *roads* shall be constructed to the applicable *Standards* for the corresponding *roadway* classification.

Public *roads* and all constructed improvements or modifications shall remain under the responsibility of the *Applicant/Contractor* until such time that the City accepts the *road* in writing in accordance with Section 2.04.

3.02 Private Roads

Private *roads* may be appropriate for some *roads* which have a fixed number of accessing lots or units, and/or expected limited *traffic* volumes.

- A. Private *roads* may be approved only when they are:
 1. Classified as a private access tract, alley, or joint-use *driveway* as set forth in Chapter 5 and Chapter 6,
 2. Permanently established by tract or easement providing legal access to each affected lot, dwelling unit, or business of sufficient width to accommodate required improvements. Language on the recorded documents establishing the access permissions shall include provisions for future use by adjacent property owners when applicable,
 3. Accessible at all times for emergency and public service vehicle use,
 4. Outside the limit of any planned future public *roads* in the present or future *street* plan per the Kenmore Comprehensive Plan, Transportation Improvement Plan, or Capital Improvement Program,
 5. Not going to result in land locking of parcels,
 6. Designed to serve a maximum potential number of dwelling units that can possibly be served by the *road* when physical barriers, zoning or other legal constraints are considered,
 7. Maintained by a capable and legally responsible owner or homeowners' association, or other legal entity made up of the benefited property owners, which is clearly assigned on the recorded document granting access permissions,
 8. Clearly described on the face of the plat, short plat, binding site plan, or other document recorded on the title of all affected properties, and
 9. Clearly signed at the *street* location as a private *road*.
- B. The City will not maintain private *roads*.
- C. The City will not accept a private *road* for conversion to public *roads* when the *roadway* is a dead-end *road* that does not exceed 500 feet in length as noted in Section 5.03 or serves the minimum number of residential units for private *road* as noted in Chapter 6.
- D. In the event a private *road* meets the minimum requirements to classify as a public *road*, the City will not accept the private *road* for conversion to a public *road* if the infrastructure is aged, worn, damage, failing, or not in compliance with current *Standards*. The private *road* shall be repaired and/or reconstructed per these *Standards* prior to City acceptance. Any private *road* with a pavement condition rating less than Good (PCI<80) as determined by the City will require a 2-inch grind and overlay.

- E. If a short plat has been proposed on a property to which the only access is over private *roadways* that fail to meet the standards specified in this section, the short plat may be denied, or be required to improve the private *road* to these *Standards* based on a determination of its impact by the *city engineer*.
- F. Private *road* tracts/easements shall include language that allows the City to convert the private *road* to public without approval from the adjacent property owners. Conversion of private *road* to public may be delegated to the *Applicant*.

3.03 Alternative Road Designs

The City of Kenmore seeks to promote and encourage the design of *roads* using the best available sciences and practices. These *Standards* are intended as general guidelines meant to be applied to a wide range of project types. Where specific projects can be better served by alternative *road* design elements such as shared spaces, living *streets* (Woonerf concept), cycle tracks, green alleys, parklets, and curb extensions, the *Applicant* and City staff shall coordinate the alternative design elements and promote the use of such design in a manner that adequately addresses the safety and accessibility concerns of the City. Some basic guidelines for alternative design types have been provided in Chapter 6 but do not provide all the details needed for full construction and implementation of such designs; the *Applicant* must provide a unique design for such *road* types. Generally, alternative *road* designs shall be privately maintained unless otherwise approved by the *city engineer*.

Chapter 4: Construction Control and Inspection

4.01 Basis for Control of the Work

Provisions of Section 1-05 of the *WSDOT* Standard Specifications shall apply, with the term "Engineer" therein construed to be the *city engineer* as defined in Section 1.02.

- A. Work performed in the construction or improvement of public or private *roads* shall be done in accordance with these *Standards* and approved plans. No work may be started until such plans are approved and a pre-construction meeting is held with the City. Any revision to the approved plans shall be approved by the City before being implemented.
- B. The *city engineer* is authorized to enforce the *Standards* as well as other referenced or pertinent specifications or guidelines. The *city engineer* may appoint representatives as necessary to inspect the work and enforce the *Standards* on his/her behalf.

4.02 Inspection

Generally, control and inspection will be done by the City on all *roadway*, *walkway*, and drainage facility construction proposed or in progress. The City also performs the maintenance/defect inspections. The *city engineer* must approve any variances from the *Standards* during construction.

- A. The *Applicant/Contractor* is responsible for quality control of construction and the assurance of meeting the approved plans and *Standards* for the project. City *inspectors* monitor these activities with enforcement authority when requirements are not met. All work conducted on electrical and communications systems shall be inspected by the Washington State Department of Labor and Industries, unless and until these services are offered by the City.
- B. A preconstruction conference shall be scheduled by the City at a time and place established by the City. Three working days advanced notice will be given of the conference date, time and location. Conference must precede the beginning of construction and include the *Applicant*, general *Contractor*, and other applicable participants. Plan approvals, permits/*contracts*, liability insurance coverage, and financial agreements/guarantees must be in hand prior to the conference.
- C. All materials provided by the *Applicant/Contractor* shall be subject to inspection and approval by the City *Inspector* at any time during the progress of work until final acceptance. The project's construction schedule shall include sufficient time for materials testing and any required verification by the City *Inspector*.
- D. The City *Inspector* has the authority to reject defective material and suspend work that does not meet with the approved plans, specifications and *Standards*. The City *Inspector* may advise the *Applicant* or *Contractor* of any faulty work or materials; however, failure of the City *Inspector* to advise the *Applicant* or *Contractor* of faulty or nonconforming work does not constitute acceptance or approval. At the City *Inspector's* order, the *Applicant/Contractor* shall immediately remedy, remove, replace, or dispose of unauthorized or defective work or materials and bear all the costs of doing so.
- E. All *roadway*, *walkway*, and drainage infrastructures must be inspected and approved prior to any final acceptance of the improvements.
- F. Prior to any critical task being started, the *Applicant* must coordinate with the City *inspector*. At a minimum, the following critical tasks require advance notification:
 - 1. Clearing and Temporary Erosion/Sedimentation Control: Two working day notice prior to initial site work involving drainage and installation of temporary erosion/sediment control.
 - 2. Curb and *Sidewalk* Placement: Two working day notice to verify proper forming and preparation prior to placing concrete.

3. Structural Inspection for Concrete Walls/Vaults/Foundations: Per *Special Inspection Sheet*, project specifications, and/or guidance of City staff
 4. Storm drainage facilities - 2 working day notice for:
 - i. Pipe installation prior to backfill
 - ii. Trench backfill (if in *right-of-way*)
 - iii. Vault foundation verification
 - iv. Vault installation prior to backfill
 - v. Vault backfill (if in *right-of-way*)
 5. Pavement: 2 working day notice prior to verify subgrade and 2 working day notice for paving activity.
 6. Street lights: 2 working day notice prior to installing foundation
 7. Landscaping: 2 working day prior notice for inspecting plant quality and placement for *right-of-way* plantings and storm drainage facilities.
 8. Substantial Completion Inspection: 5 working days prior notice
 9. Final Inspections:
 - i. 5 working days prior notice for Final Inspection.
 - ii. 5 working days prior notice from expiration of the maintenance and defect period.
 - iii. The *Applicant's* responsibilities under the terms of the maintenance and defect agreement shall not end until the improvements are formally accepted in writing by the City of Kenmore.
- G. It is the *Applicant's/Contractor's* responsibility to request all inspections. The City may not necessarily track when inspections are needed. Failure to notify the City of any inspection will not relieve the *Contractor* from performing the work as required by the permit and *Standards*. See Section 4.05 for additional information.
- H. Chips/cracks on public *sidewalk/curbing/driveway approaches*: Replacement of concrete panels or curbing due to cracking or chipping may be required and will depend upon the width, the reason for the cracking/chipping and the number of cracks/chips in each feature. In general, all cracks and chips will be evaluated on a case-by-case basis. When required, concrete panels and curbing shall be replaced from expansion joint to expansion joint; no sawcutting will be allowed unless approved by the City *Inspector*. The following general guidelines will be used for determining when corrective action may be required:
1. Any crack greater than 1/8" in width at any location
 2. Any crack that creates a vertical differential greater than 1/8" at any location
 3. More than 1 crack (regardless of width) with less than a 2-foot separation
 4. Any feature that the *Contractor* did not protect which resulted in a crack/chip or if the *Contractor* did not use standard construction methods and practices in performing the work that resulted in the damage.
 5. Chips, in general, may be repaired if they are less than 2 inches in all directions. Proposal for repair must be reviewed and approved by the *Inspector* prior to repair work starting. Chips larger than 2 inches in any direction will require a replacement of the panel or segment.

4.03 Substantial Completion Approval

The following section shall be applicable to subdivision projects, site development permits (engineering and grading permits), and *right-of-way* permits. Substantial completion approval for *City projects* shall be per *WSDOT Standard Specifications* and the project's special provisions.

- A. It shall be the practice of the City of Kenmore to require a minimum level of constructed improvements prior to recording plat documents or issuing a certificate of occupancy and all projects shall obtain substantial completion approval prior to recording final documents.
- B. Substantial completion shall require verification that the following items have been addressed; approvals from agencies other than the City of Kenmore must be provided in writing to the City *inspector*:
 - 1. Access provided to all lots within a *development*.
 - i. For hot mixed asphalt (*HMA*) pavements, access is interpreted as all but the last 2 inches of lift of the asphalt pavement.
 - ii. For concrete and pervious pavements on internal *driveways* and private *roadways*, a compacted gravel surface is acceptable for access; paved surfaces must still be provided within the *right-of-way*.
 - 2. Adequate parking provided for the proposed uses of buildings to be occupied.
 - 3. Required *ADA* facilities (*sidewalks*, curb ramps, railings, etc.), meeting the latest *ADA* Standard Guidelines, installed for the access to buildings to be occupied.
 - 4. Frontage improvements installed, safe, unobstructed to the public, and *ADA* compliant.
 - i. Pavement markings shall be provided as directed by the City *inspector*.
 - 5. Compaction and testing reports for all paved surfaces, backfill, and concrete structures must be provided to the City *inspector*. Failure to provide proof of adequate special inspection testing may require post performance sampling/testing, replacement of material, or extended maintenance and defect bonding period at the discretion of the *city engineer*.
 - 6. Drainage system installed and functional.
 - 7. Water and sewer installed and functional (as determined by the water & sewer district)
 - 8. Mail delivery system/mailbox installed and approved by the Postmaster.
 - 9. Construction equipment, stockpiles, and other materials removed from within the *right-of-way* and stored on private property with appropriate erosion and sediment control measures in place.
 - 10. Major safety concerns eliminated (fall hazards, trip hazard, sight distance issues, etc.)
 - 11. All exposed soils temporarily stabilized, and all remaining stockpiles covered in compliance with erosion and sediment control standards.
 - 12. All required regulatory signage installed.
 - 13. All required landscaping must be installed or bonded.
 - 14. All required mitigation plantings must be installed or bonded.
 - i. On site mitigation areas or critical areas must be delineated by temporary fencing.
 - 15. All required recreation equipment must be installed or bonded.
 - 16. All required lighting installed.
 - 17. Video inspection of storm drainage system completed and delivered to the City for review.
 - 18. Covenants are recorded on all lots.
 - 19. Additional performance agreement and financial guarantee filed with the City to ensure timely completion of the project.

4.04 Final Construction Approval

The following section shall be applicable to subdivision projects, site development permits (engineering and grading permits), and *right-of-way* permits. Final construction approval for *City projects* shall be per *WSDOT* Standard Specifications and the project's special provisions.

- A. Prior to closing any permit for site improvements or release of performance bonds associated with a project, the project shall obtain final construction approval.
- B. Final construction approval shall require verification that the following items have been addressed:
 1. All item listed in Section 4.03 except the additional performance agreement (Section 4.03.B.19 above).
 2. All exposed soils or slopes shall be permanently stabilized.
 3. Final *HMA* pavement lift plus pavement joint sealing has been installed and approved.
 4. All other work noted on the approved plans has been completed.
 5. All final punch list items must be addressed as directed by the City *Inspector*.
 6. As-built or final record drawings shall be submitted to and approved by the City.
 7. Verification of the constructed detention volume from the Licensed PE or surveyor.
 8. Storm drainage system has been accepted by the City.
 9. All required *road* monuments shall be installed, and a licensed surveyor shall provide written statement that the monuments have been correctly installed and registered with the State.
 10. Critical areas shall be permanently delineated and required signage shall be installed.
 11. Covenants are recorded on any remaining lots.
 12. Required agreement and financial guarantee for maintenance and defect period must be submitted to the City.

4.05 Penalties for Failure to Notify and Obtain Approval

Notification by the *Applicant/Contractor*, at the necessary time frames noted above, is essential for the City to verify, through inspection, that the work meets the approved plans and *Standards*. Failure to notify and obtain approval will result in the City requiring additional sampling and testing with certification by a City approved laboratory. Costs of such testing and certification shall be borne by the *Applicant/Contractor*.

If the test results conclude that the work does not meet the approved plans, specifications and *Standards*, the *Applicant/Contractor* will be required to remove the material and replace it with materials that meet the approved plans and *Standards* at their own expense. At the time that such action is directed by the City, further work on the *development* may be limited or prohibited until all directed tests have been completed, approved, and all corrections identified by the City have been made to the satisfaction of the City *Inspector*. If necessary, the City may take further action as set forth in *KMC* 1.20.

4.06 Control of Materials

The following standards apply to *roads* (public and private) and publicly maintained storm drainage systems only and do not pertain to site *development*. The provisions of Section 1-06 of the *WSDOT* Standard Specifications apply in all respects to all construction.

- A. Source of Supply and Quality of Materials: The *Applicant/Contractor* shall notify the City of proposed sources of supply for all materials to be furnished. The City shall approve the source of supply of each of the materials before the installation. Representative preliminary samples or test data of the character and quality prescribed may be required to be submitted by the *Applicant/Contractor* or producer for examination. Materials suppliers listed on the *WSDOT* Qualified Product List (QPL) do not require prior City approval; a copy of the QPL is required.
- B. Only materials conforming to the requirements of the *WSDOT* Standard Specifications shall be used in the work, unless otherwise approved by the *city engineer*. Any material proposed to be used may be inspected or tested at any time during their preparation and use. If after testing it is found that sources of supply that have been approved do not furnish a product that conforms with *WSDOT* Standard Specifications, or if the product from

any approved source proved unacceptable at any time, the *Applicant/Contractor* shall furnish approved materials from other approved sources. Any approved material that becomes unfit shall not be used.

- C. Samples and Tests: The *Applicant/Contractor* is required to retain the services of a certified testing laboratory to conduct necessary field and/or lab tests of materials or methods. Testing shall be in accordance with *WSDOT* Standard Specifications and/or *AASHTO/ASTM* standards. Materials shall not be used until approved.
1. Minimum testing frequency shall be as follows:
 - i. Soil Compaction Testing (trench): one test per every 50 feet on each lift. *Inspector* may, at their discretion, reduce the number of tests if compaction placement and density is consistent. Portals 2 feet by 2 feet or greater shall be considered a trench. Portals smaller than 2 feet by 2 feet may be verified with a hand held probe.
 - ii. Soil Compaction Testing (*roadway/sidewalk*): One test every 50 feet per lane or *sidewalk*. If *roadway* and *sidewalk* grades are constructed at the same time, testing under *sidewalk* is not required. *Inspector* may, at their discretion, reduce the number of tests if compaction placement and density is consistent.
 - iii. Subgrade Leveling Course: Visual inspection if lift is less than 6 inches. If greater than 6 inches, follow requirements of 1(ii).
 - iv. Asphalt Pavement: One test every 50 feet per lane per lift.
 - v. Wall/Structure backfill: One test per every 50 feet on each lift on each side receiving backfill. *Inspector* may, at their discretion, reduce the number of tests if compaction placement and density is consistent. Backfill testing is not required when wall/structures are not within the *roadway* footprint.
 - vi. Retaining walls (reinforced concrete/soldier pile): 3 compression tests (28d, 28d, spare) cylinders for each day concrete is poured.
 2. The *Applicant/Contractor* shall provide the City with certified copies of the complete test reports directly from the testing laboratory.

4.07 Construction Control in Developments

Where applicable, the provisions of Section 1-05 of the *WSDOT* Standard Specifications apply in all respects to *development* construction.

4.08 Sub-grade

In preparing the *roadbed* for surfacing before any paving, the requirements outlined in Sections 2-06.3(1) and 2-06.3(2) of the *WSDOT* Standard Specifications shall be met. After the subgrade preparation has been completed, it shall be thoroughly checked by the *Applicant/Contractor* using a level, string line, crown board, or other means to determine that the subgrade conforms to the approved *road* section and the *Standards* prior to placing any surfacing material.

4.09 Traffic Control During Construction

Traffic control shall follow the guidelines of Section 1-07.23 and 1-10 of the *WSDOT* Standard Specifications. All barricades, signs, delineators, and flagging shall conform to the requirements of the most current *MUTCD* Manual. Signs must be legible and visible, with consideration for the horizontal and vertical curvature of the *roadway*, existing vegetation, and legal *street* parking. Signage should be removed or covered at the end of each workday if not applicable after construction hours.

- A. Temporary *Traffic* Control: The *Applicant/Contractor* shall be responsible for *traffic* control during construction

on or along City *roads*. When work is to be performed on City *roads* that are open to *traffic*, the *Applicant/Contractor* will be required to submit a *traffic* control plan for approval prior to permit approval. Any alterations to reviewed *traffic* control plans shall be reviewed by the *Inspector* prior to beginning the work.

1. Lane closures will be allowed between the hours of 9:00am and 3:30pm unless otherwise approved by the *city engineer*.
 2. Flaggers are required at all times when a *roadway* is reduced to one-way only or when *traffic* visibility is obstructed by construction activity. All flaggers shall possess a current Washington State certified flagging card.
 3. Pedestrian access shall not be blocked or restricted. If pedestrian access cannot be maintained, flaggers may be used to safely escort pedestrians around the work area, or a detour plan shall be submitted and approved (see bullet "E" below).
- B. Temporary *Road* Closures and Detours: The City may consider requests for full *road* closures where they are determined by the *city engineer* to be in the best interest of the public:
1. A proposal for a *road* closure and a detour plan must be prepared and submitted to the City at least 10 working days in advance; said plan must be approved by the *city engineer* prior to closing any City *street*.
 2. The types and locations of the signs shall be shown on a detour plan.
 3. The *Applicant/Contractor* shall post "This Road Will Be Closed" signs, along with the anticipated dates and times of closure, a minimum of 7 calendar days prior to the closing.
 4. The *Applicant/Contractor* must notify, in writing, local fire, school, law enforcement authorities, Metro transit, adjacent parcels owners, and any other affected persons as directed by the City at least 10 days prior to *road* closure.
 5. Businesses and residences adjacent to the closure shall be notified via door hangers three (3) calendar days prior to the closure. Arterial *street* closures require variable message signs (VMS) posted on site five (5) calendar days prior to closure. Any residential *street* closure greater than 9 hours will require a VMS posted on site three calendar days prior to closure.
 6. The *Applicant/Contractor* may be required, at the direction of the *city engineer*, to notify adjacent property owners via door hangers or mailers along the detour route three (3) calendar days prior to the closure.
 7. *Shoulder* closures affecting parking shall require on-site notification of said closure 48-hours prior to the closure. Notification shall be on A-frame boards stating the project, permit number, dates and times of closure, contact information, and location (limits) of closure. At the discretion of the *city engineer*, notification fliers may be required for adjacent properties/businesses and parked cars.
- C. Haul Routes: The *Applicant/Contractor* shall be required to develop and use a haul route. Haul routes shall be limited to arterials and collector *streets* when at all possible.
1. The haul route plan must be prepared and submitted to the *city engineer* and approved prior to beginning or continuing construction. The haul route plan shall address routing, hours of operation, signage and flagging, and daily maintenance.
 2. If the *Developer/Contractor's* fails to use the designated haul route, the *city engineer* may prohibit or limit further work on the *development* until such time as the requirements of the haul route are complied with. The City may also require restoration to *roads* utilized outside of the haul route. Restoration would be at the City's discretion.
 3. The haul route shall be identified on the plans.
- D. Haul *Road* Agreement: When identified as required by the SEPA review process or by the City, a haul *road* agreement shall be obtained by the *Applicant, utility, Developer, or property owner* establishing restoration procedures to be performed upon completion of the haul operation.

- E. Pedestrian Circulation Plan: Where a *development* or construction activity will obstruct an existing pedestrian *walkway* regularly used by pedestrians, a pedestrian circulation plan shall be required prior to beginning any construction activity. The pedestrian circulation plan must identify alternative access routes to safely direct pedestrians travelling in, around, or through a work area.
 1. Where existing pedestrian facilities exist outside the limits of the work zone, they may be utilized as the alternative pedestrian path provided that pedestrian connections with the existing pedestrian path can be made at safe and legal locations and appropriate signage is provided, in compliance with *MUTCD*, to direct pedestrian movements to the alternative routes. All pedestrian connections shall be *ADA* compliant to the maximum extent feasible/practical.
 2. Where existing pedestrian facilities cannot move pedestrians around a work zone, a temporary alternative pedestrian pathway must be provided and must be compliant with current *ADA* standards to the maximum extent feasible/practical, including, but not limited to, temporary ramps where required and continuous cane-detectable barriers around the revised pedestrian route.
 3. All barricades, signs and flagging shall conform to the requirements of the *MUTCD*. Signs must be legible and visible and should be removed at the end of each workday if not applicable after construction hours.
- F. Bicycle Circulation Plan: Where a *development* or construction activity will obstruct, close, or create a hazardous condition of loose pavement or material on an existing marked bicycle lane or travel lane marked with a *sharrow* symbol, a bicycle circulation plan shall be required prior to beginning any construction activity. The bicycle circulation plan must address signage to notify cyclists of the closure and/or hazardous condition (plates on *roadway*, uneven pavement, gravel, etc.), alternative access routes and detours for cyclists and signage notifying drivers on alternative access routes of the increased presence of cyclists during construction. All barricades, signs and flagging shall conform to the requirements of the *MUTCD*. Signs must be legible and visible, considering horizontal and vertical curves and overhanging vegetation, and should be removed or covered at the end of each workday if not applicable after construction hours.

4.10 Call Before You Dig

Contractors are responsible for timely notification of *utilities* in advance of any construction in *right-of-way* or *utility* easements as required under [RCW 19.122](#). The *utility* One-Call Center phone number (1-800-424-5555) or 8-1-1 should be prominently displayed on the work site.

4.11 Utility Certification

All permits for new placement and replacement of existing *utilities* and *utility* structures shall be accompanied by written certification from the *utility's* professional engineer or from an agent authorized by the *utility* to certify that the installations conform to the appropriate standards and that the proposed work is in conformity with sound engineering principles relating to *street* safety.

4.12 Final Cleanup and Restoration

In addition to restoration of the *road* as required by these *Standards*, the responsible *Applicant, utility, Contractor, etc.*, shall care for adjacent areas in compliance with Sections 1-04.11 and 8-01 in the *WSDOT* Standard Specifications. In particular:

- A. *Roads* shall be cleaned and swept both during and after the installation work.
- B. Disturbed soils shall be final graded, seeded and mulched after installation of *utility*. In limited areas seeding and mulching by hand, using approved methods, will be acceptable.
- C. Ditch lines with erodible soil and subject to rapid flows may require seeding, matting, netting, or rock lining to

control erosion.

- D. Any silting or accumulation of construction debris of downstream drainage facilities, whether ditches, pipes, or catch basins, which resulted from the construction activity shall be cleaned out and the work site restored to a stable condition as part of site cleanup.
- E. Remove all temporary erosion and sediment control materials and fencing and dispose of properly.

Chapter 5: Private Roads, Driveway, and Parking Design

All accesses to individual buildings or lots shall be located, designed, and constructed to balance multimodal transportation needs and maximize public safety on the *road* system. This chapter provides location and design criteria for access at the *right-of-way* line, access approaches in the *right-of-way*, *private roads*, and *driveways* or circulation *roads* internal to a private property.

5.01 General

Each lot shall have direct access to the public *right-of-way*. If a project site is not immediately adjacent to the *right-of-way*, access must be achieved by a recorded easement or by a recorded access tract.

- A. The circulation system of *developments* shall intersect with existing and anticipated *streets* abutting the site at safe and convenient locations.
- B. Every lot upon which a building is proposed to be erected or a *traffic* generating use is proposed to be established shall establish direct access from the *roadway* as needed to provide public services such as fire protection, emergency service, mail delivery or trash collection.
- C. The designers of proposed *developments* must consider the access and *driveway* profile to ensure that required grade transitions can be complied with while considering building setbacks, terrain, and grades.
- D. All traffic control devices, including signs and pavement markings, shall meet the *MUTCD* standards.
- E. All *private roads*, *driveways*, and parking lots shall be paved with either hot mix asphalt or concrete.
- F. The use of *LID* practices is required where feasible on *private driveways*, *private roadways*, and *off-street* parking areas.
- G. Access tracts and/or *roads* required to provide access to two or more lots shall be developed to the width and standard required for its entire length. The practice commonly known as, or that yields the effect of, “telescoping” improvements (i.e., a *street* required to serve a short plat being reduced in width as the number of remaining lots decreases) is expressly prohibited.
- H. Any portion of a paved *roadway*, parking area, *driveway*, and/or *private road* located on private property, whether paved or not, shall be setback a minimum of 5 feet from all property lines. Connections to the *right-of-way* are exempt.
- I. The City may require additional connections for bicycles and pedestrians as directed by the *city engineer* as noted in Section 2.05.
- J. For commercial or industrial internal (private) *roads* with heavy *traffic* volumes or significant numbers of trucks, the City may require construction of the access as an intersection with an arterial and/or may require additional reinforcement within the *sidewalk*, *driveway* and approach sections within the public *right-of-way*. This requirement will be based on *traffic* engineering analysis submitted by the *Applicant* that considers, among other factors, intersection spacing, sight distance, and *traffic* volumes.
- K. Concentrated *surface water* flows (e.g., pipe discharges, gutter flows, trench flows, etc.) shall not be permitted to cross *sidewalks* or any other *walkways*.

5.02 State Highways

Access points to the state highway system are regulated through the Revised Code of Washington (*RCW*). The only state highway within the City of Kenmore is State Route 522/Bothell Way NE (SR522).

- A. Per *KMC* Chapter 12.85, a City connection permit will be required for any new, alteration, or relocation of *driveways* or *streets* that intersect with SR522.

- B. Any *development* that requires the construction of a new *driveway*, a relocation/modification of an existing *driveway*, *utility* service connections, or construction of a new *road* that intersects a state or federal highway may require a permit from the Washington State Department of Transportation (*WSDOT*). *Applicant* must contact *WSDOT* for additional information and requirements.
 - 1. This project must comply with all applicable State standards, as noted above, in addition to designing for City standards.
 - 2. Where State or federal standards conflict with these *Standards* and/or *KMC*, the more restrictive requirement shall prevail.
- C. See *KMC* Chapter 12.85 for additional requirements for *driveways* connecting to SR522.

5.03 Private Roads

All newly created *roads* that create a *street end* (dead-end) shall be a private *road* per these *Standards*. Newly created dead-end *roads* or extensions of existing private dead-end *roads* shall become public if the final length of the *road* measured from centerline of intersecting public *street* to furthest extent of the proposed *road* exceeds 500 feet or as noted in Table 6.1.

- A. Private *roads* are to be privately owned and maintained and shall be constructed as outlined in Chapter 6.
- B. Private *roads* shall be clearly identified and dedicated in an easement or tract and noted on the plat map to be recorded, if applicable. Dedication language shall include a clear designation of maintenance responsibility for the improvements within the easement or tract.
- C. At the discretion of the *city engineer*, where a *street* is proposed (either through City planning or possible *development* through zoning allowances) that may, in the future, be connected to an existing public *road* or extend the private *road* beyond the 500-foot threshold, the *road* shall be constructed to meet minimum standards for a public *road* for the proposed *road* classification.
- D. Private *roads* shall have language included in the final plat map allowing additional parcels to connect to the proposed private *road* and to make alterations to the track to accommodate future *development*. Future connecting parcels shall be added to the maintenance responsibility of the private *road* through recorded documents on each property title.
- E. Private *roads* (including maintenance *roads*) shall be designed to accommodate access (pedestrian and/or vehicle depending upon facility) to any storm drainage facility. Specific access requirements shall be coordinated with Public Works. All private *road* tracts shall have language that allow access for maintenance and/or replacement purposes.
- F. Before a private *road* can be made public, the private *road* shall be improved to meet the *Standards* for a public *road*. Exemptions may be approved on a case-by-case basis.
- G. If a private *road* is to be converted to public *right-of-way*, the *Applicant* shall be responsible for all documentation and recordings necessary to transfer the private *road* to public ownership including notifications to adjacent property owners.
- H. Alleys, when appropriate, shall be designed to meet all the following standards:
 - 1. Serve a maximum of 30 dwelling units
 - 2. Have a maximum length of 400 feet
 - 3. One-way *road* that connects two other *streets* (private or public); alleys cannot be dead-ends or cul-de-sacs and shall not intersect other alleys.
 - 4. In a dedicated tract with a minimum width sufficient to construct the alley and related grading.
 - 5. The minimum paved width shall be 10 feet, maximum paved width shall be 14 feet.
 - 6. The surface shall be paved, sloped to the centerline of the alley and provided with an inverted crown to

control surface runoff as far from the buildings structures as feasible. Catch basins shall be provided in each alley to collect storm water prior to crossing any current or proposed *walkways*.

7. Modifications to existing alleys may be considered on a case-by-case basis subject to approval by the *city engineer*.
 8. Approaches shall be per Section 5-04A/B (1. and 2.)
 9. An alley may not serve as the only access to a lot.
- I. Private *roads* shall be designed to meet all the following standards:
1. Design widths for all private *road* features shall be per Table 6.1.
 2. Private *road* approaches (from a public *road*):
 - i. Shall be designed per the *driveway* standards in Section 5.04.
 - ii. Private *road* approaches shall be designed to accommodate the uses and volume of *traffic* served. Approach widths exceeding these *Standards* may be required at the *city engineers* discretion.
 - iii. Private *road* approaches may be required to be designed with a specific turning radius and/or curb returns as determined by the Fire Marshall.
 - iv. Where private *roads* are required to be designed with curb returns, private *roads* shall be spaced per Section 7.02 when feasible, otherwise to the maximum extent possible.
 3. Obstructions (such as, but not limited to: walls, fences, poles, and above ground *utilities* features) shall be placed a minimum of 1 foot beyond the limits of the paved surface.
 4. When located along an existing or proposed property line, the paved access (not including separated pedestrian *walkways*) shall be positioned within the tract to accommodate a 5-foot setback along the property line.
 5. Geometric design and profile shall meet the standards of a local *road*.
 6. If the length, measured from centerline of intersecting *street* to furthest extent of the *road* exceeds 150 feet in length as measured in 5.03A, a turnaround must be provided and approved by the Fire Marshal. See Section 6.10 for turnaround design requirements.
 7. Paved surface may be installed with an inverted crown (flow-line in the center) or sloped in one direction with a vertical curb to control surface runoff. Catch basins shall be provided in each private access tract to collect storm water prior to crossing any current or proposed *walkways*. Additional easements may be required for *utilities* and drainage.
 8. *Surface water* from new *roads* shall not be permitted to flow across any public *walkway* unless otherwise approved by the *city engineer*.
- J. Joint use *driveways* shall be designed to meet all the following standards:
1. A joint use *driveway* shall serve a maximum of two (2) dwelling units.
 2. Pavement width shall be between 16 and 20 feet.
 3. Minimum tract width shall be the pavement width plus 6 feet when adjacent to an existing property line; if not positioned along an existing property line the tract width may be reduced to 2 foot plus the pavement width.
 4. Obstructions, such as walls, fences, poles, above ground *utilities* feature, shall be placed a minimum of 1 foot beyond the limits of the paved surface.
 5. The paved access shall be positioned within the tract to accommodate a 5-foot setback along an existing property line and 1-foot setback along newly created property lines.
 6. The length, measured from centerline of the nearest intersecting public *roadway* to the end of the last *driveway* (a, shall not exceed 300 feet in length without a *street end* (see Section 6.10). Additional

requirements for pavement radii and pavement width may be necessary as determined by the *city engineer*.

7. Paved surface may be installed with an inverted crown (flow-line in the center) or sloped away from the adjacent property line with a thickened edge or curb to control surface runoff. Catch basins shall be provided in each private access tract to collect storm water prior to crossing any current or proposed *walkways*.
8. *Driveway* profiles and elevations shall comply with the intersection grade requirement per Section 7-06.
9. Additional easements may be required for *utilities* and drainage.
10. Joint use *driveways* shall comply with Section 5.04. Any conflicts with this Section and Section 5.04, the stricter provision shall apply.

5.04 Driveways and Driveway Approaches

This section provides *driveway* and *driveway approach* standards to public and private *roads*. It is not the intent of these *Standards* to govern design or location of *driveways* on private property except where they connect to the *road* where minimum setbacks are required along property lines and where safety is a concern. However, fire access requirements governed by the Fire Code (KMC 15.10) and KMC Title 18, establish criteria for *driveway* widths.

A. General *Driveway/Driveway approach* Requirements:

1. New *driveway approaches* shall generally comply with KSD 8-006 for Type 1 *Driveway approach*. The *sidewalk* at back of the *driveway* apron shall be designed to meet ADA Standard Guidelines. Elevation changes required for the *driveway* apron to meet *road* grade shall be accomplished within the limits of the *Amenity Zone* and shall not intrude upon the *sidewalk*.
2. Type 2 *Driveway approaches* (depressed *driveways*) are not permitted on public *roadways* unless otherwise approved by the *city engineer*. Exemptions may be granted on a case-by-case basis where existing *sidewalk*, on local *roads* in front of adjacent parcels, has no *Amenity Zone*. Type 2 *driveways* are allowed on private *roads*. If approved, depressed *driveways* shall generally be designed and constructed to comply with KSD 8-007.
3. A *right-of-way* use permit or engineering permit, as appropriate, is required by the City prior to beginning construction within the *right-of-way*.
4. *Driveway approaches/driveways* must be paved within the limits of the public *right-of-way*. From back of *sidewalk* (or pavement edge if no *sidewalk*) to the *right-of-way* line, pavement may be either asphalt or concrete. Concrete pavers may be allowed as a temporary installation until such time as a *sidewalk* is constructed.
5. *Driveway* profiles and elevations shall comply with the intersection grade requirement per Section 7-06.
6. All abandoned *driveway/driveway approach* areas along the frontage shall be removed. The curbing, *sidewalk*, and/or *shoulder* and ditch section shall be properly restored to these *Standards*.
7. Maintenance of *driveways* and *driveway approaches*, including any regulatory signage or pavement markings, shall be the responsibility of the owner whose property they serve.
8. The City and franchised *utilities* are not obligated to replace alternative surfacing material within the public *right-of-way* with a like material and may, at the *city engineer's* discretion, replace existing *driveways* and *driveway approaches* with standard asphalt or concrete within the *right-of-way*.
9. Grade transitions, excluding the tie-in to the *road*, shall be constructed as smooth vertical curves. The maximum change in *driveway* grade within the *right-of-way* shall be 8 percent within any 10 feet of distance on a crest and 12 percent within any 10 feet of distance in a sag vertical curve. Whenever there is a potential for future *road* widening, the *driveway* shall be graded to match the future widened *road*

section without encroachment into the *sidewalk*.

10. For *driveways* crossing an open ditch section, culverts shall be adequately sized to carry anticipated storm water flows and at a minimum the culvert shall be equal to or larger than any existing pipes within 500 feet upstream or downstream; in no case shall the minimum pipe size be less than 12-inch in diameter. Pipe should be long enough to account for the *driveway* side slopes and shall be per KSD 7-001 (Beveled End Pipe Section) and 7-011 (Debris Cage for Culvert). The property owner making the installation shall be responsible for determining proper pipe size. The City may require the owner to verify the adequacy of pipe size.
 - i. Additional requirements may apply when the *driveway* crosses a classified stream per KMC 18.55 including, but not limited to, fish passable culvert, habitat restoration, and other requirements for a *Hydraulic Permit Approval* (HPA) from WDFW.

11. Storm drainage from *driveway* and *driveway approach* surfaces must be accounted for in the *roadway* drainage design.

B. *Single family Residential Driveway and Driveway approaches:*

1. *Driveways* and *driveway approaches* must be a minimum length of 20 feet, measured along any point between the nearest tract/easement/*right-of-way* line of a shared access or *roadway* and the nearest edge of the parking area/carport/garage required per KMC 18.40.030. *Driveways* may not exceed 45 feet in length if feasible.
2. *Driveway* and *driveway approaches* shall have a minimum width of 12 feet and a maximum width as follows:
 - i. *Driveways* and *driveway approaches* accessed from private *roads* shall have a maximum width of 35 feet.
 - ii. *Driveways* and *driveway approaches* accessed from public *roads* shall have a maximum width of 20 feet at the *right-of-way* line. *Driveways* may be widened to a maximum of 35 feet beginning at a minimum of 5 feet from the *right-of-way* line.
3. *Driveways* shall be continuously paved or surfaced with gravel between the public *right-of-way* and the parking area required by KMC 18.40.030, unless otherwise approved by the City of Kenmore.
 - i. This requirement shall not restrict the use of alternative pavement types (such are porous pavements or pavers) and methods (such as wheel strips) to meet flow control BMP or *LID* requirements.
 - ii. *Driveways* with a slope exceeding 5% in grade shall be paved; gravel surfacing will not be permitted on steep *driveways*.
4. If frontage improvements do not exist and are not required, *driveway approaches* from the right of way line to the edge of pavement shall be *HMA* unless otherwise approved by the *city engineer*.

C. Duplex/triplex *driveways* and *driveway approaches* shall be as required per bullet B for *single family*.

D. Commercial, Industrial, & Other *multi-family Driveways* and *Driveway approaches:*

1. *Driveways*, when designed, must be a minimum length of 40 feet, measured along any point between the nearest tract/easement/*right-of-way* line of a shared access or *roadway* and the nearest edge of the parking area/carport/garage required per KMC 18.40.030.
2. *Driveways* and *Driveway approaches* shall have a minimum width of 24 feet and a maximum width of 36 feet for commercial and industrial sites. *Driveway* width may be reduced to 12 feet for one-way direction *driveway approaches*.
3. *Driveways* and *Driveway approaches* shall have a minimum width of 20 feet and a maximum width of 24 feet for *Multi-Family* sites. *Driveway* width may be reduced to 12 feet for one-way direction *driveway approaches*.

4. *Driveways* shall be continuously paved between the public *right-of-way* and the parking area require by *KMC 18.40.030*.

- i. This requirement shall not restrict the use of alternative pavement types (such are porous pavements or pavers) and methods (such as wheel strips) to meet a flow control BMP or Low Impact *Development* requirement.

E. *Townhome Driveways and Driveway approaches:*

Driveway lengths shall be 20 feet when accessed from a public *road* with a width between 8 feet and 20 feet. *Driveways* are not required when accessing from a private *road*. If *driveways* are proposed off of a private *road*, they shall follow the requirements for access from a public *road*. *Driveway approaches* to garages from private *roads* shall not exceed 10 feet in length. Any conflicts with the *KMC*, the *KMC* shall prevail.

F. Location of New *Driveways*.

1. *Driveway* location is subject to City approval.
2. No portion of *driveway* width shall be allowed within 5 feet of any existing side property lines.
 - i. Exceptions may be granted without a formal variance request for access panhandles to single lots and for lots taking access from a cul-de-sac bulb; in such cases the *driveway* shall be located, and possibly reduced in width, to provide the largest setback feasible.
 - ii. A setback variance may be approved if approval from the adjacent property owner(s) is received.
 - iii. For duplexes and triplexes, a *driveway* may be allowed within 3 feet of any existing side property line if landscaping is provided to screen the *driveway* from the neighboring property. Appropriate landscaping shall be determined by the City during permit review.
3. No two *driveway approaches* along a public *right-of-way* shall be closer together than 20 feet on arterial/collector *roads* and 10 feet on local *roads* where it intersects with the *street right-of-way* line. Distance is measured from the edge of the *driveway*.
 - i. Exceptions may be granted without a formal variance request for access panhandles and for lots taking access from a cul-de-sac bulb; in such cases the *driveway* shall be located, and possibly reduced in width, to provide the largest separation feasible.
4. On frontages 100 feet or less, no more than one *driveway/driveway approach* per lot shall be constructed. On frontages over 100 feet, the City may permit two *driveways/driveway approaches* per lot, subject to bullet 5 of this section, Section 10.02, maximum combined width of both *driveways* not to exceed the maximum *driveway* width per 5.04 B and C, and *city engineer* approval.
5. Project sites which have multiple frontages, such as corner lots or lots with public *roads* on the front and back of the lot, access must be taken from one side only and access must be from the *street* with a lower classification (or volume) unless otherwise approved by the *city engineer*. Removal of existing improvements or obstruction such as, but not limited to, walls, fences, or existing *utilities* shall not be sufficient to determine an access infeasible. Additional access from the other frontages may be granted where all *road* frontages exceed 100 feet, subject to *city engineer* approval.
6. *Driveways* shall not be allowed within 30 feet of an existing or planned intersection radius return (curb or edge of pavement) and shall be positioned as far from an intersection as feasible.
7. *Driveways* shall not be allowed within 20 feet of any marked crossing.
8. *Driveways* shall be located at existing or proposed easements or tracts adjacent to the property.
9. *Driveways* shall intersect the *right-of-way/tract/easement* at an angle between 85° and 95° and shall maintain this requirement for all portions of the *driveway* which lie within a public *right-of-way*. Exceptions may be granted for *driveways* within the limits of a cul-de-sac bulb.
10. *Driveway approaches* along SR522 shall follow the requirements of *KMC* Chapter 12.85. Where a conflict

arises between *KMC 12.85* and these *Standards*, *KMC 12.85* shall prevail.

11. Notwithstanding any other provisions, *driveways/driveway approaches* will not be allowed where they are prohibited by separate City Council action or where they are determined by the City to create a hazard or impede the safe operation of *traffic* on the *road*.
- G. For land *development* projects and/or changes in use, existing *driveways* and *driveway approaches* which do not conform to this chapter shall be reconstructed to the *Standards*.
- H. Pedestrian/bicycle sight distance must be maintained for all *driveways* and *driveway approaches*.
 1. For the intersection of a *driveway* with a public *street*, a sight distance triangle for a site access point shall be determined by measuring 15 feet along the edge of travel way and 15 feet along the edges of the *driveway* beginning at the respective points of intersection. The third side of each triangle shall be a line connecting the end points of the first two sides of each triangle.
 2. Where pedestrian *walkways* exist at an intersection of a *driveway* with the public *street*, a sight distance triangle for a site access point shall be determined by measuring 15 feet along the back edge of the *walkway* and 15 feet along the edges of the *driveway* beginning at the respective points of intersection. The third side of each triangle shall be a line connecting the end points of the first two sides of each triangle.
 3. For the intersection of a *driveway* with a public *street* with bicycle facilities a sight distance triangle along the *driveway* shall be determined by measuring 100 feet along each bicycle facility approach which must be crossed by a vehicle entering *traffic* from the *driveway* and 10 ft along the edges of the *driveway* at the near edge of the bicycle facility. The third side of each triangle shall be a line connecting the end points of the first two sides of each triangle. Larger sight distance triangles for bicycle facilities may be required at the discretion of the *city engineer*.
 4. With the exception of narrow objects (sign posts, single mail box posts, trees, *utility poles*, etc.), the area of sight distance triangle between 3.5 and 8 feet above finished grade shall remain clear.

5.05 Parking

Parking, including the amount of required off-street parking stalls, stall dimensions, and drive isle dimensions and layout, shall be designed and constructed in compliance with *KMC 18.40*.

- A. On-street parking stalls located within or requiring turning movements within the public *right-of-way* shall not be counted toward the required number of off-street stalls except as permitted by *KMC 18.29.070*.
- B. Design for on-street parking or parking within the *right-of-way* shall:
 1. Comply with the dimension requirements of *KMC 18.40*, and
 2. Be located outside of existing vehicle travel lanes, and
 3. May require additional pavement width in excess of the minimum widths listed in these *Standards*, and
- C. On-street parking stalls may be removed at any time at the discretion of the *city engineer*.
- D. The number of *ADA* compliant parking stalls provided on each site shall comply with *KMC 18.40.060* and current *ADA* Standard Guidelines.
- E. *ADA* stalls shall be designed per *ADA* Standard Guidelines.
- F. Where off-street parking stalls and *driveways* are not directly accessed from the public *right-of-way*, *roadways* providing access to the off-street parking area shall meet the standard of a private *road* including the requirement for a pedestrian *walkway*.
- G. All marked pedestrian crossings on private internal commercial drive aisles shall be designed and constructed as speed tables which provide an elevated crossing for pedestrians.

1. Speed tables shall be treated with colored concrete, pavers or other visual cues to the presence of the table and crosswalk.
- H. For marked on-street parking, design and location shall comply with *ADA* Standard Guidelines.

Chapter 6: Road Design

This chapter sets the minimum standards for geometric *street* design of public *roads*, commercial/industrial *roads*, and private *roads* where noted. The City's *roadway* classification map is included in Appendix A.

6.01 Reconstruction

Reconstructed, altered, widened, or improved *roads* shall be brought into compliance with these *Standards*.

- A. For the purposes of this section, *utility* installations alone shall not be considered reconstruction but must still meet the *Standards* and requirements of Chapter 11.
- B. Transitions or tapers necessary to connect with existing *roads* of a different width shall meet *AASHTO* and *MUTCD* standards.

6.02 Applicable Standards

Projects adjacent to an existing *road* shall improve the existing *road* to the current *Standards* for its current classification per Section 6.03, 6.04, or 6.05, except where project impacts result in a reclassification of the *road*.

- A. Projects adjacent to existing *roads* in which the project impacts result in the change of the *road* classification as noted below shall be required to improve the entire *road* to the current *Standards* for the new classification. Limits of the *roadway* upgrade shall be determined by the City.
- B. Subdivision and residential projects shall construct internal *roads* per Section 6.04 or Section 5.03.
- C. Commercial, industrial, *townhome*, and *multi-family* projects shall construct internal *roads* per Section 6.05 and Section 5.03, as applicable. The classification of new internal *roads* for these types of projects shall be determined by the City.
- D. Private *roads* for *townhome* and *multi-family developments* shall construct internal *roads* providing access to parking areas per Table 6.1 and Section 6.05, except that the required 4-foot *sidewalk* on private *roads* may be relocated as needed to provide pedestrian access to the main entrance of each unit.
- E. Alternative *road* designs may be proposed on any *road* type when approved by the *city engineer*. Alternative *road* sections shall follow the guidance of Section 6.13.

6.03 Typical Road Cross Sections

Right-of-way widths shall be a minimum of 60-feet. Local *road* widths may be reduced to 46 feet at the discretion of the *city engineer*. *Right-of-way* dedications may be necessary to meet the minimum *right-of-way* width. The *city engineer* shall determine the amount of dedication required to meet the minimum *right-of-way* width.

Certain *roads* have an established cross section that may differ from the standard design requirements shown in the *Standards*. Those *roads* shall be improved in accordance with the *Standards* AND to the configuration and widths as shown in the appropriate Figure in Appendix B. Any conflicting information between the cross sections and other requirements in the *Standards*, the cross sections shall take precedence.

6.04 Typical Sections for Single Family Residential Access Roads

New *roads* for *single family* residential projects shall be constructed per Table 6.1. For existing *roads* (including private *roads* converting to public), the *road* classification identified for that *road* will be used to determine the *Standards* for design in Table 6.1.

- A. Vertical curbing is required on both sides of all *roadway* types unless an inverted crown or full width sloped *road* is proposed and approved.
- B. Vertical curbing shall be constructed per Sections 8.02, 8.03, and 8.04.
- C. On local *roads*, *sidewalk* is required on any side of the *road* which will be adjacent to newly created lots, structures, or *driveways*; in no case shall a *road* be constructed without *sidewalk* on at least one side.
 - 1. Maintenance access *roads*, required solely for *utility* or park maintenance, shall not trigger the *sidewalk* requirement.
 - 2. New *roads* where new lots, structures, or *driveways* are only proposed on only a portion of one-side of the *road*, the frontage improvement requirements shall be applied to the entire length of proposed *roadway* out to the nearest intersecting *roadway*.
 - 3. For new single lot *developments*, structures or *driveways*, frontage improvements shall be required the full width of the parcel.
 - 4. Additional *walkways* may be required for *roads* which are identified as priority pedestrian routes or school walk routes or where additional *sidewalk* will close a less-than-25-foot gap created in the *sidewalk* network by the new *development*.
- D. *Sidewalk* shall be constructed per Sections 8.01, 8.03, and 8.04.
- E. *Amenity Zones*, per Section 8.10, are required on as noted in Table 6.1. Where *sidewalk* is proposed on public *roads*, *Amenity Zones* are required between the curb and *sidewalk* unless otherwise approved by the *city engineer*.
- F. Half-street Improvements: Where a proposed *road* is adjacent to an *undeveloped parcel* or a parcel that may be subdivided per the *KMC*, the *roadway* shall be sized to accommodate future *development* on the adjacent parcel(s). Only in the case that the anticipated use of the adjacent site increases the residential *roadway* classification which would have otherwise been required for the immediate or initial project, the *Developer* shall be required to improve the *road* to a half-street standard. The half-street standard shall:
 - 1. Require a minimum pavement width per Table 6.1.
 - 2. Maintain a minimum 5-foot setback between the edge of pavement and adjacent property line.
 - 3. Slope *roadways* to drain to gutter line. Crown of *road* shall be located on far side of *roadway*.
- G. In cases where a project develops next to a *road* previously constructed with a reverse crown or sloped in one direction, and the *road* shall be made (or currently is) a public *road*, the *road* shall be constructed to these *Standards*. The *Applicant* shall be required to saw cut the pavement at the future *roadway* center as determined by the City and establish a typical crown. The *Applicant* shall construct all required elements on the near side of the established crown.
- H. Arterials or collectors intersecting with other arterial or collector *roads* shall be 32 feet wide for the first 150 feet. Total improvement and *right-of-way* widths shall be adjusted accordingly.
- I. Edge of travel lane for private *roads* shall be built with a 5-foot minimum distance from any residential zoned property line.
- J. Pavement markings shall be clearly shown on the project construction drawings and shall be reviewed by the City prior to construction of the *roadway* improvements. Pavement markings shall be designed to maximize traffic calming opportunities while maintaining on-street parking to the maximum extent feasible.
- K. Parking restrictions shall be consistent with Table 6.1 except where otherwise directed by the City. Where parking restrictions are required, the *Applicant* shall be responsible for “no parking” signs in compliance with *MUTCD*.
- L. See Chapter 9 for pavement design and material requirements.

6.05 Typical Sections for Commercial, Industrial, Townhome & Multi-Family Access Roads

New *roads* for commercial/industrial projects shall be constructed per Table 6.1. At the discretion of the *city engineer*, where a *street* is proposed (either through City planning or possible *development* through zoning allowances) that may

be connected to an existing public *road*, the private *road* shall be constructed to meet minimum standards for a local *road*. See Section 5.03 for further requirements.

- A. New *roads* for *townhome* projects may be constructed as either public or private *roads* as noted in and to the general widths provided for in Table 6.1.
- B. For existing public *roads*, see cross sections in the Appendix. If no cross section exists, *road* widths shall be per table 6.1.
- C. Access to public owned sites (parks, maintenance yards, public buildings, etc.) and *utility* infrastructure sites shall be classified as Industrial/Commercial.
- D. Curbing shall be constructed per Sections 8.02, 8.03, and 8.04.
- E. *Sidewalks* on internal *roads* are required for publicly accessible site *developments* unless otherwise approved by the *city engineer*.
- F. On *roads* required to be public, *sidewalk* is required on any side of the *road* which will be adjacent to newly created lots, structures, or *driveways*.
 - 1. Maintenance access *roads*, required solely for *utility* or storm water maintenance alone, shall not trigger the *sidewalk* requirement.
 - 2. Where new lots, structures, or *driveways* are only proposed on a portion of one-side of the *street*, the *sidewalk* requirement shall be applied to the entire length of proposed *road* out to the nearest intersecting *roadway* with a *walkway*.
 - 3. For new single lot *developments*, structures or *driveways*, *sidewalk* shall be required the full width of the parcel.
 - 4. Additional *walkways* may be required for *roads* which are identified as priority pedestrian routes or school walk routes or where additional *sidewalk* will close a less-than-25-foot gap in the *sidewalk* network.
 - 5. Assessable routes shall be continuous from the end of the proposed *road* to the connecting *road*. *Road* crossing treatments may be required as directed by the City.
- G. *Sidewalk* shall be constructed per Section 8.01, 8.03, and 8.04.
- H. *Amenity Zones*, per Section 8.10, are required as noted in Table 6.1.
- I. *Roads* intersecting with arterial or collector *roads* shall be a minimum of 32 feet wide for the first 150 feet. Total improvement and/or *right-of-way* widths shall be adjusted accordingly.
- J. Edge of travel lane shall not be built within 5 feet of a residential property line.
- K. Pavement markings shall be clearly shown on the project construction drawings and shall be reviewed by the City prior to construction of the *roadway* improvements. Pavement markings shall be designed to maximize traffic calming opportunities while maintaining on-street parking to the maximum extent feasible, if required.
- L. Parking restrictions shall be consistent with Table 6.1 except where otherwise directed by the City. Where parking restrictions are required, the *Applicant* shall be responsible for “no parking” signs in compliance with *MUTCD*.
- M. See Chapter 9 for pavement design and material requirements.

Table 6.1: Road Width Standards¹

Road Type	Arterial/Collector	Local Road	Private Road ⁶
General Description	<ul style="list-style-type: none"> As noted on the <i>Road Classification Map</i> Others as approved 	<ul style="list-style-type: none"> Generally providing access to a fixed number of lots Dead-end <i>roads</i> >500 ft in length <i>Townhome</i> project/site - (>50 units); 	<ul style="list-style-type: none"> Dead-End <i>roads</i> ≤500 ft in length <i>Townhome</i> project/site - (≤50 units); <i>Multi-Family</i> project/site Industrial/Commercial <i>Roads</i>
Public or Private	Public	Public	Private ⁷
Design Speed²	35 mph	25 mph	15 mph
Pavement Width³ (Curb to Curb)	Case-by case basis	20 feet Minimum (28 feet with parking) ⁵	20 feet
Total Minimum Improvement Width³ (Back of walk to back of walk)	Case-by case basis	41 feet (49 feet with parking)	25 feet ^{8,10}
Total Minimum Right-of-way/Tract Width³	Case-by case basis	46 feet	26 feet ^{8,10}
Sidewalk Requirement⁹	Both Sides	Both Sides	One side ⁸
Minimum Sidewalk Width	6 feet	6 feet	4 feet
Amenity Zone Requirement	Both sides	Both sides	None
Minimum Amenity Zone Width	4 feet	4 feet	N/A
Curb Type	Vertical	Vertical	Vertical or Rolled ¹⁰
Pavement Marking⁴	As directed	As directed	None
On-Street Parking⁵	No Parking Allowed	Allowed on both sides (7-8 ft width)	Allowed on both sides
Typical Lane Width	10.5 feet	10 feet	N/A

- The following standards are typical for the *roadway* type listed. Additional requirements/widths are outlined in the *road* cross sections in Appendix B and take precedence over this table.
- The design speeds listed are a basis for determining geometric elements and does not imply posted or legally permissible speed.
- Bike lanes with buffer or additional *utility* service requirements may be required, increasing the total width of the cross section. Additional *road* width is required near intersections with arterial or collector *roads* per Section 6.04.H and 6.05.I.
- Pavement marking shall be as directed by the City in compliance with Section 6.04.J and 6.05.K.
- Parking requirements are general recommendations subject to City review and approval. Parking on one side may be allowed within the minimum 20-foot pavement width at the discretion of the *city engineer*. See cross sections for exceptions. Signage is required in compliance with Section 6.04.K and 6.05.L. On street parking is not allowed on Industrial/Commercial interior roads.
- For alleyway requirements, see section 5.03H.
- Existing public *streets* proposed for access shall remain public and revised to meet minimum requirements of that *road* classification.
- Sidewalk* may be substituted with a 4-foot paved *shoulder* separated by a 4-inch white stripe for private *roads* that serve ≤4 units and are ≤100 feet in length.
- Pedestrian connections from *sidewalk* to all main entrance doors must be made.
- Curbing is not required where an inverted crown is installed.

6.06 Stopping Sight Distance

Stopping Sight Distance (SSD) is required for approaches (public and private) to all *roadways* regardless of classification. SSD shall not apply to all-way stop-controlled intersections. SSD is the sum of two distances; the distance traveled during perception and reaction time and the distance required to stop the vehicle. For pedestrian sight distances, see Section 5.04G. The following are for all intersecting *roadways* (public and private):

- A. Measurements shall be taken from the inside edge of the travel lanes. If a marked bike lane is present, measurements shall be taken from the center of the bike lane.
- B. The perception and reaction time used in design is 2.5 seconds at the design speed. The stopping sight distance is calculated using a constant deceleration rate of 11.2 feet/second².
- C. The grade of the *roadway* effects the vehicle's stopping sight distance. The stopping distance is increased on downgrades and decreased on upgrades. When calculating sight distance with a changing grade, use the grade for which the longest sight distance is needed. *Road* grades other than those shown in Table 6.2 must be interpolated or calculated from the below equation:

$$S = 1.47 * V * (2.5) + \frac{V^2}{30 * [0.347826 \pm (G/100)]}$$

Where:

S = Stopping sight distance on grade (ft)

V = Design speed (mph)

G = Grade (%)

Table 6.2: Stopping Sight Distances

Minimum Sight Distance Required (ft)							
DESIGN SPEED (MPH)	No Slope	3% Down	6% Down	9% Down	3% Up	6% Up	9% Up
45	360	378	400	427	344	331	320
40	305	315	333	354	289	278	269
35	250	257	271	287	237	229	222
30	200	205	215	227	200	184	179
25	155	158	165	173	147	143	140
20	115	116	120	126	109	107	104
15	80	80	82	85	75	74	73

- D. When evaluating forward stopping sight distance, use an eye height of 3.50 feet and an object height of 0.50 feet. When evaluating intersection stopping sight distance a 2-foot object height may be used.
- E. Sag vertical curves on residential or commercial *streets* that do not meet the minimum SSD may be approved by the *city engineer* if no practical design exists and if acceptable illumination is provided throughout the curve and is maintained by a franchised *utility*. Illumination shall be per Section 8.11. Additional signage may be required as determined by the *city engineer*.

6.07 Entering Sight Distance

Entering Sight Distance (ESD) requirements in this section and in Table 6.3 apply under average conditions. In difficult topography, the *city engineer* may authorize a reduction in the ESD based on factors mitigating the hazard. Such factors may include an anticipated posted or average running speed less than the design speed or the provision of acceleration lanes and/or a median space allowing an intermediate stop by an approaching vehicle making a left turn. Specific ESD values for required design speeds are listed in Table 6.3 or calculated from the below equation.

- A. ESD applies to the following locations:
 - 1. Intersections with arterial *roads* with stop control on the minor leg only; or
 - 2. *driveway approaches* to an arterial *road*; or
 - 3. Approaches within the ESD triangle from a signalized intersection.
- B. Entering vehicle eye height is 3.5 feet, measured 10 feet back from edge of traveled way. Approaching vehicle height is 2 feet.
- C. Where a significant number of trucks will be using the approach *road*, the *city engineer* may increase the entering sight distance requirements by up to 30 percent for single-unit trucks and 70 percent for semi-trailer combinations.
- D. Measurements shall be taken from the inside edge of the travel lanes. If a marked bike lane is present, measurements shall be taken from the center of the bike lane.

$$E_s = 1.47 * V * t_g$$

Where:

E_s = Entering sight distance on grade (ft)

V = Design speed (mph)

t_g = 7.5 seconds (see footnotes of table 6.3)

Table 6.3: Entering Sight Distances

Design Speed (mph)	20	25	30	35	40	45
Entering Sight Distance (Ft.) ^{1 2 3}	220	275	330	385	440	495

¹ Entering sight distance shown is for a stopped passenger vehicle to turn left onto a two-lane arterial with no median and an approach grade of three percent or less for the turning vehicle. For other conditions, the time gap should be adjusted and required sight distance recalculated. (See *AASHTO – Intersection Control* section).

² For multilane *roadways*: For left turns onto two-way arterials with more than two lanes, add 0.5 seconds for passenger cars or 0.7 seconds for trucks for each additional lane from the left, in excess of one, to be crossed by the turning vehicle.

³ For minor and approach grades: If the approach grade is an upgrade that exceeds three percent; add 0.2 seconds for each percent grade for left turns.

6.08 Horizontal Curve Criteria

The minimum centerline radius on local *roads* shall be as shown in Tables 6.4 or calculated from the below equation. For combination curves (horizontal and vertical), refer to *AASHTO*.

- A. Super-elevation is not required in the design of horizontal curves on local *roads*.

- B. Should the re-design of an existing arterial or construction of a new arterial be needed, the horizontal curvature shall be designed in accordance with current *AASHTO* standards.
- C. See Table 6.1 for required design speed values.
- D. Horizontal curve radii may be reduced based upon the expected travel speeds as designed by a Licensed PE. Reductions in minimum radius design value may require supplemental signage as directed by the City.

$$R_{min} = \frac{V^2}{15 * (0.01 * e_{max} + f_{max})}$$

Where:

R = Radius

V = Design speed (mph)

e = Superelevation rate (in decimal form)

f = side friction factor

Table 6.4: Minimum Radius Design Values

Design Speed (mph)	15	20	25	30	35
f _{max} (e = 0%)	0.32	0.27	0.23	0.2	0.18
Minimum Radius (Ft.)	47	99	181	300	454

6.09 Vertical Alignment

Maximum *roadway* grades on all newly constructed *roads* shall not exceed 15% maximum. Grades exceeding the maximum requirement require approval from the Fire District and *city engineer*.

- A. Grades exceeding 10 percent shall be paved with hot mixed asphalt (*HMA*) or portland cement concrete (*PCC*).
- B. Grade transitions shall be constructed as smooth vertical curves, without angle points, except in intersections where the difference in grade is one percent or less.

6.10 Street Ends

All public *roads* with a *street end* require an approved turnaround. Any private *road* that serves more than six lots or which extends more than 150 feet from the centerline of the accessing *road* to farthest extent of the surfaced traveled way (including *utility access roads*) requires an approved turnaround.

- A. Hammerheads: A hammerhead turn around may be used to satisfy the turnaround requirements for joint use *driveways* and for private *roads* between 150 feet and 300 feet long.
 - 1. Hammerhead shall be designed per *KSD 2-002*.
 - 2. Final hammerhead dimensions and layout shall require Fire Marshal approval.
- B. Permanent Cul-de-sac Bulbs: A cul-de-sac bulb is the required turn-around type for any public *roadway* and any private *roadway* greater than 300 feet in length. Cul-de-sacs shall be constructed as follows:
 - 1. Cul-de-sac shall be designed per *KSD 2-003*.
 - 2. Minimum *right-of-way* diameter across bulb section: 100 feet in a permanent cul-de-sac; *right-of-way* may be reduced if approved by the *city engineer*.

3. A Minimum 80-foot diameter of asphalt pavement across bulb is required.
 4. The City may require an emergency vehicle access and/or an off-street *walkway* to connect a cul-de-sac at its terminus with other *roads*, parks, schools, bus stops, or other pedestrian *traffic* generators.
 5. The City may require signage or pavement markings to be installed within the bulb to restrict parking and maintain emergency access.
 6. The maximum cross slope in a bulb shall not exceed 6 percent in any direction.
- C. Temporary Cul-de-sac Bulbs: If a *street* temporarily terminates at a property boundary that may potentially become public (see Section 5.03) and is longer than 150 feet, a temporary bulb shall be constructed near the *development* boundary.
1. A temporary public easement shall be provided for the bulb area lying outside the typical *right-of-way*.
 - i. Temporary cul-de-sac easements shall be extinguished once the proposed *street* extension is constructed and approved by the City.
 - ii. The *Applicant /Developer* will be responsible for preparing the necessary documentation to extinguish the easement.
 2. The paved bulb shall be 80 feet in diameter with *sidewalks* terminated at the point where the bulb radius begins.
- D. Removal of the temporary constructed cul-de-sac, restoration of landscaping, pavement markings, and construction of the extension of the *sidewalk* shall be the responsibility of the *Applicant/Developer* who extends the *road*.
- E. A cul-de-sac island will not be permitted unless it is included as a flow control BMP, *LID* feature, or other surface storm water facility which will be maintained as a storm water facility by the City or a homeowners association. If an island is proposed, the full limits of the paved cul-de-sac bulb shall be sloped toward the island and all runoff shall enter to island area without the need for additional storm drain inlets within the paved limits.

6.11 Access and Circulation

No *road* shall serve more than 50 *single family* resident lots or *townhome* units unless the *road* is connected to another *road* that functions at a same level or higher. *Roadway* upgrades to these *Standards* on existing *roads* may be required. Additionally, a secondary access shall be required at the direction of the Fire Department.

- A. The second access requirement may be satisfied through use of connecting a new *road* to an existing *road* if:
 - (1) No other practical alternative exists, or
 - (2) Existing *road* was previously stubbed indicating intent for future access, or
 - (3) An easement has been recorded specifically for said purpose.
- B. The second access requirement may cause the construction of an *off-site road* connecting the *development* to a suitable serving *road*.
- C. These provisions are not intended to preclude the state statute on land locking.
- D. This section does not preclude a non-residential project from gaining access through a residential *development*. *Traffic* impacts for such projects will be analyzed during the environmental and permitting process.

On parcels with multiple frontages, front doors shall take access off of the higher classified *road* and *driveway* access shall be taken from the lower classified *road*.

6.12 Traffic Calming and Safety Treatments

Wherever necessary for the safe operations of multi-modal transportation to address existing or anticipated speed concerns or to mitigate for *traffic* volume impacts as determined by the *city engineer*, the City may require traffic calming measures on newly constructed or existing *roadways*. The City's most recent Traffic Calming Program Policies and Procedures shall be followed prior to installation of any traffic calming device. In addition to signing and pavement markings, the following are types of traffic calming treatments that may be considered:

A. Speed Humps:

1. Speed humps shall generally be designed, constructed, and marked per *KSD 2-005*
2. Considerations for drainage shall be applied where proposed speed humps obstruct the existing or natural flow of *surface water*.
3. Speed humps which cross an existing or proposed *walkway* shall be modified to maintain a pedestrian pathway which is *ADA* compliant.
4. Speed humps which cross an existing or proposed bicycle lane shall be modified to provide appropriate consideration for bicyclists.
5. Speed *bumps*, identified as those devices with widths along the direction of travel that are less than 3 feet, are not permitted on public *roads* unless written justification for their use due to site restrictions is provided to the City and is approved by the *city engineer*.
6. Size and location of speed humps shall be coordinated with the Fire Marshall and ambulance services.

B. Chicanes/Pinch Points:

1. When it is determined that a *roadway* or section of *roadway* is to be narrowed that allows only one vehicle to pass at a single time, a lane width between 10 and 14 feet shall be provided for vehicular *traffic*.
2. Pinch points may be created by placement of on-*street* parking, curb extensions, pavement markings/tubular markers, or other delineations as approved by the *city engineer*.
3. Chicanes may be created and shall be uniquely designed for each site to address emergency access concerns and shall be approved by the Fire Marshal prior to construction of the improvements.
4. Considerations for drainage shall be applied where proposed chicanes or pinch point devices obstruct the existing or natural flow of *surface water*.
5. Chicanes/Pinch points which cross an existing or proposed *walkway* shall be modified to maintain an *ADA* compliant pedestrian pathway.
6. Chicanes/Pinch points which cross an existing or proposed bicycle lane shall be modified to provide appropriate consideration for bicyclists.

C. Traffic Circles/Mini-Roundabouts:

1. The impacts evaluated for implementation of traffic circles or mini-roundabouts may exceed the typical *Level of Service* evaluation and shall include safe movements for all users of the intersection including pedestrians, bicyclist, personal vehicles, anticipated transit vehicles, anticipated freight/service vehicles, and emergency services vehicles.
2. Mini-Roundabouts shall be uniquely designed for each site but shall generally follow the guidelines of the *WSDOT Design Manual* Chapter 1320.
3. Traffic circles shall be uniquely designed for each location but shall generally follow *KSD 2-001*.

D. Speed Tables or Raised Crosswalks:

1. In some unique cases, the City may request that portions of or the entire intersection be raised; the raised intersection shall generally be designed with the same guidelines.

2. Speed tables are required on all marked pedestrian crossings on all internal commercial/mixed use access roads.
3. Speed tables shall generally be designed and constructed per KSD 2-004
4. Speed tables must be constructed of a material which is of different color and texture than the drive aisle it crosses. If concrete is used on the top (flat) portion of the table, it must be stamped and/or textured with a pattern more distinguishable than standard brushing.

E. Speed Feedback Signs:

1. Speed feedback sign manufacturer and model shall be determined by the City.
2. Signs may be solar or AC power as directed by the City.
3. Locations for signs shall be as directed by the City.
4. A minimum of one sign shall be installed in each direction.

The following safety treatments may be considered:

A. Rectangular Rapid Flashing Beacons (RRFB):

1. May be located at all priority pedestrian crossing routes. Priority routes are school walk routes, access to transit stops, and other locations as determined by the *city engineer*.
2. The system shall be hard wired unless otherwise approved by the *city engineer*. Solar powered systems may be approved at the discretion of the *city engineer*.
3. RRFB shall flash in both directions of vehicle travel. The final system shall be approved by the *city engineer* prior to installation.
4. Advanced warning speed feedback signs may be required at the discretion of the *city engineer*.

B. Mid-Block Crossings:

1. RRFBs and cross walk markings are required at all marked mid-block crossings.
2. Pedestrian lighting shall be evaluated and may be required at all marked mid-block crossings.
3. Advanced warning flashing signs shall be required on each approach.
4. Signs and beacons must be hard-wired unless otherwise approved by the *city engineer*. Solar powered systems may be approved at the discretion of the *city engineer*.

Alternative traffic calming and safety treatments not listed here may be proposed. Proposal must include a description of proposed treatment(s), justification for the alternative proposal, evidence of effectiveness, product data sheets and manufacturer (if applicable), and design schematic. All alternative traffic calming and safety treatments will require approval by the *city engineer*.

6.13 Alternative Road Design Guidelines

Where specific projects can be better served by alternative *road* design elements such as shared spaces, living streets/Woonerf, cycle tracks, green alleys, and parklets, the *Applicant* and City staff shall coordinate the alternative design elements to promote the use of such designs in a manner that adequately addresses the safety concerns of the City. Some basic guidelines for some alternative design types have been provided below but these guidelines do not provide all the details needed for full construction and implementation of such designs; the *Applicant* must provide a unique design for such *road* types. Alternative *road* designs shall be privately maintained.

- A. **Living Streets:** The Living Street, shared-space *roadway*, or “woonerf” involves creating a *road* which is shared among pedestrians, bicyclists, and motor vehicles, and where pedestrians have priority over motor vehicles. The *road* is designed without a clear division between pedestrian and motor vehicle space (i.e., no continuous curb), to reduce vehicle speed and to encourage travel with caution. The *street* is lined with *street* furniture (e.g.,

planters, *street* trees, benches), parking areas, and areas for social interaction to encourage reduced vehicle speeds but also to promote greater use of the shared space. The end result is a *road* which is a livable and attractive environment for a variety of activities.

1. For *roads* which permit only one direction of travel, a minimum horizontal vehicle clearance of 10 feet shall be maintained.
2. For *roads* which allow two directions of travel, a minimum horizontal vehicle clearance of 16 feet shall be maintained.
3. The *road* must not include a continuous above-grade curb.
 - i. Short curb sections may be used in association with the required physical features noted below.
 - ii. A sunken curb or other method of distinguishing the surfaces available to vehicle travel may be required to meet current *ADA* Standard Guidelines.
4. The *road* must be paved with an alternative pavement type which differs in color and texture from the adjacent *roadways* and *walkways*; concrete, if proposed, must be colored and stamped with a pattern more distinguishable than standard brushing. Pervious pavers are an acceptable alternative pavement type for such a use.
5. Physical features such as *street* furniture, parking stalls, play areas, art, bike racks, and other constructed elements shall be provided on alternating sides of the *roadway* so that the minimum vehicle clearance is not exceeded for more than 50 continuous feet, unless otherwise approved by the *city engineer*.
 - i. The required physical features shall create a shift in the vehicle clear area between 1/3 and 1/2 of the total vehicle clearance width, unless otherwise approved by the *city engineer* (i.e. If a vehicle lane is 16 feet wide, the travel lane centerline must shift by 5.3 feet minimum and 8 feet maximum).
 - ii. The required physical features, including parking stalls, shall be rotated in use so that the same physical feature is not provided in consecutive locations along the *road*.
 - iii. Trees must be provided at minimum of 1/4 of the required *roadside* features.
6. The *road* must maintain a minimum “comfort zone” of 4 feet on each side. The comfort zone is the area beyond the limits of a straight line drawn along the outer limits of the vehicle path (farthest vehicle travel point on each side).
7. The *road* must include a sign at each entrance from a public/private *roadway* which states that the *road* is a shared space or living *street*; the sign shall be approved by the City prior to installation.
8. The *road* must include lighting features which are designed to provide a minimum of 1.5 foot-candles to all portions of the *road* and physical features with an average-to-minimum uniformity ratio of 3:1; the comfort zone need not be assessed for lighting.
9. Where parking stalls are provided within a living *street*, they may be counted toward the required minimum parking per *KMC* 18.40, provided that turning movements into the public *right-of-way* are not required to enter/exist the stall.

Chapter 7: Intersection Design

The design criteria in this chapter apply to *roadway* intersections. Intersections, as applied in this chapter, shall not include individual residential *driveways* or joint-use *driveways*, but shall include all other *road* types, both public and private. Intersection design shall conform to the guidelines set forth in *AASHTO* Policy on Geometric Design to the maximum extent feasible. For state highways, refer to *WSDOT* design manual(s).

7.01 Alignment

The angle of an intersection of two *roadways* or a *driveway* with a *roadway* shall be between 85° and 95° and must maintain this angle within the *right-of-way* for a minimum of 10 feet beyond the *right-of-way* or easement line for *driveways* and 30 feet beyond the curb radius for two *roadways* intersecting. Exceptions may be granted for *driveways* within the limits of a cul-de-sac bulb.

7.02 Spacing

Spacing between adjacent intersecting *streets*, whether crossing or T-connecting, shall be as shown in Table 7.1.

Table 7.1

When highest classification involved is:	Minimum centerline offset shall be:
Major Arterial and State Highway	500 feet
Minor Arterial	300 feet
Collector	150 feet
Local <i>Road</i> and Private <i>Road</i> *	100 feet

* See Section 5.03H

7.03 Design Vehicles

Intersections shall be designed to accommodate the design vehicle appropriate for the highest classified *street* forming the intersection.

- A. The intersection design shall accommodate the use of the *roadway* as a designated truck route, bus route, or school bus route, where appropriate. The following *roads* have been identified for design purposes only:
 1. Truck route: See *Road Classification Map*, appendix A.
 2. King County Metro/Sound Transit Bus Route: 73rd Ave NE (SR522 to NE 181st St), NE 181st St (73rd Ave NE to 68th Ave NE), 68th Ave NE (NE 181st to NE 170th St), Juanita Dr (NE 170th St to NE 153rd Pl), NE 153rd Pl (Juanita Dr to NE 155th St), NE 155th St (NE 153rd Pl to 84th Ave NE), 84th Ave NE (NE 155th St to NE 145th St), SR522
 3. School Bus Route: Coordinate with Northshore School District.
- B. The minimum design vehicle is the SU-30, although use of larger design vehicles may be required depending on *roadway* classification, truck and transit routes, and adjacent and proposed land use. Where local *roads* meet local *roads*, turning vehicles may be designed to encroach on opposing *traffic* at the discretion of the *city engineer*.
- C. All elements of the intersection shall be designed so the design vehicle will not encroach onto *sidewalks*, *walkways*, landscaped areas, or the opposing travel lane.

1. Improvements associated with traffic calming devices or alternative *road* designs may be designed with mountable curbs provided that the area is not part of a pedestrian pathway and is a paved surface.
2. Improvements associated with traffic calming devices or alternative *road* designs may be designed such that they result in temporary movements into the opposing *traffic* lane, provided that appropriate transitions and signage are provided.

7.04 Curb Radii

Curb radii design must balance vehicle turning movements with pedestrian safety. Typically, it is appropriate to use the smallest turn radii possible that still accommodates the design vehicle.

- A. Curb radii are not required for individual *driveways* (commercial or residential), alleys, and joint-use *driveways*.
- B. Private *roads* shall be designed as intersections as required in Section 5.03H.
- C. For design, round curb radii to the nearest five-foot increment.
- D. Typical curb radii based on *street* classification are shown in Table 7.2. However, these values may be impacted by site conditions, including width of receiving lanes, on-street parking, and angle of intersecting *roadways*.
- E. A proposal for a curb radius design must be accompanied by supporting documentation for review and approval by the City.

Table 7.2

<i>Street Classification</i>	Radius (feet)
Major Arterial, Minor Arterial, or Collector to Major Arterial, Minor Arterial, or Collector	35
Major Arterial, Minor Arterial, or Collector to Local Road	25
Local Road or Private Road to Local Road	20

7.05 Drainage

An intersection shall be laid out and graded so that *surface water* drains and the intersection is safe and accessible for pedestrians and bicyclists.

- A. Drainage structures shall not be placed in an *ADA* ramp, landing, or crosswalk area. Drainage structures may be installed in crosswalk area if no other feasible alternative is available.
- B. Drainage structures shall be located outside the corner radii to the maximum extent feasible.
- C. Drainage structures shall be placed at upstream side of existing or proposed curb ramps.
- D. All private *roads* shall collect onsite surface runoff and convey the runoff to the on-site or public drainage system without impacting the pedestrian or bicycle travel way.
- E. See Chapter 10 for additional requirements.

7.06 Intersection Grades

On sloping approaches at an intersection, landings shall be provided with grade not to exceed one-foot difference in elevation for a distance of 30 feet approaching an arterial or 20 feet approaching all other *streets*, measured from the edge of traveled way.

7.07 Pedestrian Treatments

Accommodations for pedestrians shall be designed into all intersections. Pedestrian accommodations include *sidewalks*, crosswalks, pedestrian refuge islands, flashing beacons, and pedestrian signals and signal buttons. All pedestrian accommodations must be designed to meet current *ADA* Standard Guidelines.

- A. Vaults, covers, castings, or drainage grates shall not be placed within the crosswalk or within curb ramps or landing areas.
 - 1. Where it is infeasible to locate *utility* structures or *LIDs* outside of the pedestrian pathway, they must be treated with a slip-resistant material in compliance with current *ADA* Standard Guidelines.
- B. Marked crosswalks shall be provided on all signal-controlled intersections, pedestrian hybrid beacons (*HAWKS*), and crossings with flashing beacons. Crosswalks may be installed on other intersections at the discretion of the *city engineer*. Where required, crosswalk markings shall comply with *KSD 4-001*.
- C. Pedestrian lighting is required at all marked crossings based upon a lighting study, see Section 8.11.
- D. Curb ramps shall be provided per Section 8.05.
- E. When *street* paving or re-surfacing impacts a crosswalk (whether marked or not) through an intersection, the intersection must be retrofitted or upgraded to meet the current *ADA* Standard Guidelines and *RCW* requirements; retrofits and upgrades may be required on all barriers, curb ramps, landings, pedestrian signals, and pedestrian push buttons associated with the impacted accessible route.
- F. Crosswalk markings on public *roads* shall be limited to plastic bars as shown in *KSD 4-001*.
- G. Curb bulbs shall be installed per Section 8.02 unless otherwise approved by the *city engineer*.
- H. Pedestrian signals and signal buttons shall be designed per the *WSDOT* Design Manual chapters 1330 and 1510 and per the *MUTCD*.
- I. Refuge islands shall be designed per the *WSDOT* Design Manual chapter 1510.

7.08 Sight Distance

Stopping sight distance (Section 6.06) and entering sight distance (Section 6.07) requirements shall apply.

7.09 Bicycle Accommodations

All intersections with arterial and collector *roads* shall be designed to accommodate bicycle facilities to the maximum extent feasible. Bicycle lanes shall be clearly distinguished with pavement markings and signage as needed to safely move vehicles and bikes through any given intersection allowing proper consideration for merging *traffic* and the addition of lanes, or lane transitions, required for turning movements through the intersection. See *KSD 4-004*.

Chapter 8: Roadside Features

8.01 Sidewalks

Sidewalk shall be constructed in the location and at the width identified in Chapter 6. *Sidewalk* width dimensions shall be exclusive of, and in addition to, any portion of the curb and gutter, retaining wall, pedestrian curbing, fencing, and/or fall protection measures.

- A. All *sidewalks* shall be constructed to meet the ADA Standard Guidelines.
- B. *Sidewalk* shall be constructed with Portland cement concrete.
 1. Permeable cement concrete pavement may shall be used where feasible per the SWDM.
 2. Permeable cement concrete pavement on private *roads* shall be maintained by the *Applicant*, adjacent property owner, or other private owner for the life of the pavement. Maintenance shall be per SWDM requirements. Language about maintenance and maintenance requirements shall be noted on the final plat map or recorded as a separate document on each tax parcel.
- C. *Sidewalks* shall be constructed between the *Amenity Zone* and the limits of *right-of-way* on public *roads*. Where an *Amenity Zone* is not provided or required, *sidewalk* shall be constructed next to the curb or parking strip unless otherwise approved by the *city engineer*.
- D. Extended off-*street walkways* may be required by the *city engineer* to provide direct connections to existing pedestrian facilities or to/along School Walk Routes as identified by the City or school district.
- E. *Sidewalk* adjacent to retaining walls shall be a minimum of 1 foot wider than the minimum width listed in Chapter 6 if wall is to be constructed directly under *sidewalk*.
- F. All *utility LIDs* within the *sidewalk* surface shall not exceed 1/8 inch in vertical (lip) and 3/8 inch in horizontal (gap) discontinuity and shall be coated with a slip resistant coating.
- G. No fixed object may be placed within the *sidewalk*, including *utility* poles bases, which restrict the *sidewalk* width to less than 6 feet, unless otherwise approved by the *city engineer*.
- H. *Sidewalks* shall be designed per KSD 8-001 and 8-008.
- I. For elevation changes at back of *sidewalk* that are less than 24 inches, *sidewalk* with thickened edge or integral curb may utilized in lieu of block wall. See KSD 8-010 and 8-011.
- J. For new construction and existing infrastructure (alterations) on public *roads*, *sidewalks* shall meet all current ADA Standard Guidelines to the maximum extent feasible/practical. Where all elements of the ADA requirements cannot be met, a Licensed PE shall provide Maximum Extent Feasible/Practical (MEF) documentation. MEF documentation must be prepared on City forms and must contain the following information:
 1. Identify all measurements of proposed *sidewalk*,
 2. Highlight all portions of *sidewalk* associated with the project which are not fully compliant,
 3. Provide justification for why those elements cannot be designed or constructed to be fully compliant,
 4. Include a stamp and signature from the Licensed PE responsible for the documentation,
 5. Be approved by the *city engineer* prior to final permit approval or release of any performance agreements if changes occur during construction.
- K. Objects between 27 in. and 80 in. may not protrude more than 4 in. into the accessible route without a cane detectable warning device.
- L. Bus stop boarding and alighting areas shall be designed per WSDOT Design Manual Chapter 1510.

8.02 Curb & Gutters

Vertical curb and gutter shall be used on all new or widened public roads.

- A. Rolled curb may be permitted where it:
 - 1. Replaces or matches existing conditions,
 - 2. is used as part of a *traffic* calming device,
 - 3. is a private *road*,
 - 4. is used as part of an alternative *road* design.
 - 5. In all cases, the use of rolled curb in the public *right-of-way* must be approved by the *city engineer*.
- B. Extruded curb is not allowed in public *right-of-way* unless otherwise approved by the *city engineer*. For maintenance purposes, existing extruded curb may be replaced in-kind or extended as needed to maintain the purpose of the extruded curb.
- C. Curbs shall be designed per *KSD* 8-009.
- D. Where practical, curb bulbs shall be located at all local *road* intersection crossings. A 20-foot width shall be maintained at crossing.

8.03 Construction of Curbs, Gutters, and Sidewalks

Curbs, gutters, and *sidewalks* shall be concrete Class 4000, furnished and placed in accordance with *WSDOT* Standard Specifications, Sections 6-02, 8-04, and 8-14. Cold and hot weather precautions as set forth in *WSDOT* Standard Specifications Sections 5-05.3(14) and 6-02.3(6)A shall apply.

- A. Sub-grade compaction for curbs, gutters, and *sidewalks* shall meet a minimum 95 percent of maximum density.
- B. *Sidewalk* shall be constructed in compliance with current *ADA* Standard Guidelines.
- C. Concrete *sidewalks* shall be cured for at least 72 hours prior to opening to pedestrian *traffic*. *Sidewalk* concrete crossing *driveway* sections shall meet full strength prior to opening to vehicular *traffic*. Curing shall be by means of moist burlap or quilted blankets or other approved methods.
- D. During the curing period, *sidewalk*, curb and gutter shall be protected from damage by all *traffic*, both pedestrian and vehicular. Methods shall be used to prohibit *traffic* from impacting the curing concrete.
- E. Transitions between elevated *sidewalks* to *shoulder road* sections shall be constructed per *KSD* 8-005 (adjusted as necessary to meet *ADA* Standard Guidelines) and meet the following requirements unless otherwise approved by the *city engineer*:
 - 1. At intersections, curb shall extend around the entire radius and transition ramp(s) to *shoulder* shall be provided at the terminus ends.
 - 2. For straight connections or mid-block transitions, a transition ramp to *shoulder* shall be provided at the *sidewalk* end(s).
 - 3. Where the bottom of the ramp lies outside the limits of existing pavement, a minimum 4-foot by 4-foot asphalt landing shall be provided which does not exceed 2% maximum slope in any direction and the entire distance between the landing and existing edge of pavement shall be paved. The new asphalt landing shall be connected to and blended with the existing pavement.

8.04 Expansion Joints and Sidewalk Finishing

All expansion joints shall consist of pre-molded joint material conforming to the requirements of ASTM D994 (*AASHTO* M33). Full depth joints shall be placed at the following locations:

- A. Around fire hydrants, poles, posts, and *utility* castings and along walls or structures in paved areas.
- B. In curbs and *sidewalks* per *KSD 8-001*, *8-008*, and *8-009*. When curbs are placed by slip forming, a pre-molded strip of expansion joint shall be installed at a minimum depth of 3 inches. Expansion joints in *sidewalk* shall be located to match the joints in the curb whether *sidewalk* is adjacent to curb or separated by planting strip.
- C. On separate pour construction, an expansion joint shall be placed full depth between the curb and the adjacent *sidewalk*.
- D. In the upper three inches of the full width of the *sidewalk* and curb at both sides of any drainage frame and grate.

Unless otherwise specified in Section 2.08, *sidewalk* finishing shall be troweled smooth with a steel trowel. Before jointing or edging, the surface of the walk shall be lightly brushed in a transverse direction (perpendicular to *roadway*) with a soft brush. Tool marks consisting of V-grooves must be made in the *sidewalk* at intervals intermediate to the expansion joints, see *KSD 8-001* and *8-008*.

8.05 Curb Ramps

On all curbed *streets* or where *sidewalk* is not at the same grade as the *road* crossing, ramped sections (curb ramps) shall be constructed at *roadway* intersections, other crosswalk locations, or anywhere a raised pedestrian facility begins or terminates.

- A. Overlays, trench cuts, microsealing which impact a marked crosswalk or other legal crossing are considered alterations of the accessible route and require upgrading the crossing with curb ramps compliant *ADA Standard Guidelines*.
- B. Adding or altering the location of a marked crosswalk is considered an impact to the accessible route and will require upgrading the crossing with curb ramps compliant *ADA Standard Guidelines*.
- C. For existing infrastructure (at alterations) and new infrastructure, curb ramps shall meet all current *ADA Standard Guidelines* to the maximum extent feasible/practical. Where all elements of the guidelines cannot be met on public *roads*, a Licensed PE shall provide documentation identifying how the design is meeting the maximum extent feasible/practical. Documentation must be prepared on City forms and must contain the following information:
 - 1. Identify all measurements of proposed ramps,
 - 2. Highlight portions of all ramps associated with the project which are not fully compliant,
 - 3. Provide justification for why those elements cannot be designed or constructed to be fully compliant,
 - 4. Include a stamp and signature from the Licensed PE responsible for the documentation,
 - 5. Be approved by the *city engineer* prior to final permit approval or release of any performance agreements if changes occur during construction.
- D. Where a curb or barrier (greater than ¼ inch lip) exists at the crossing, a new curb ramp must be installed unless otherwise approved by the *city engineer*.
- E. Replacing a curb ramp or constructing a new curb ramp will require a companion curb ramp at the other end of the crossing if a barrier exists (curb or any vertical lip greater than ¼ inch).
- F. All curb ramps shall be perpendicular per *KSD 8-002*. Parallel curb ramps per *KSD 8-003* may be used in lieu of a perpendicular ramp as approved by the *city engineer*.
- G. The curb ramp standard details (*KSD 8-002*, *8-0003* and *8-004*) are intended as general guidance to City standard requirements; errors or omissions in the detail drawings does not exempt the *Applicant* from having to fully comply with the *ADA Standard Guidelines*.
- H. In the case that *ADA Standard Guidelines* for private property are updated and the standard details no longer represent the current guidelines or interpretations, the details shall be considered void and shall not be referenced in plans or construction documents on private property.

- I. Each proposed curb ramp shall be specifically detailed on the construction drawings as follows:
 1. Unique site elevations based on the proposed design and shall provide spot elevations at all significant grade breaks including, but not limited to, all corners of the required landings, the top and bottom of ramp,
 2. Slopes in all directions (top/bottom and left/right) at the gutter, ramp, landing, and curb ramp wings,
 3. Length and width of ramp, landing, and curb ramp wings (along the curb line only).
- J. Curb ramps shall be measured from grade break/expansion joint to grade break/expansion joint for *ADA* compliance as follows:
 1. Ramp: Length (centerline), width (top, centerline, and bottom), slope (all sides and across centerline)
 2. Landing: length/width (all four sides and centerline), slope (all sides and across centerline)
 3. Wings: along the side adjacent to curb
 4. Gutter slope: perpendicular to pedestrian travel
 5. Counter Slope: parallel to pedestrian travel, centerline of ramp/landing.
- K. Concrete for curb ramps shall be Class 4000, furnished and placed in accordance with *WSDOT* Standard Specifications, Sections 6-02, 8-04, and 8-14. Cold and hot weather precautions as set forth in *WSDOT* Standard Specifications Sections 5-05.3(14) and 6-02.3(6)A shall apply.
- L. Where a ramp is constructed on one side of the *street* and a *sidewalk* or raised pedestrian facility exists on the opposite side of the *street* that does not have a curb ramp, a receiving ramp shall also be provided. Where a raised pedestrian facility does not exist on the opposite side, a second ramp is not required.
- M. Where a ramp is constructed on one side of the *street* and a vertical barrier exists on the opposite side of the *street* separating the travel way with an at grade pedestrian *walkway*, the barrier must be removed to provide a minimum of 4 feet of clearance. Final surface features shall comply with *ADA* Standard Guidelines.
- N. Two ramps shall be provided per corner to the maximum extent feasible/practical for new construction on public roads.
- O. Where existing curb ramps are impacted and require replacement, two ramps shall be provided for each corner unless otherwise approved by the *city engineer*.
- P. Curb ramps shall be positioned so that a ramp opening is situated within the marked crosswalk or crossing area if unmarked. See *KSD* 4-001 and Section 7.07 for additional direction.
- Q. Curb ramps shall have detectable warning surfaces consisting of raised truncated domes and a contrasting surface across the entire opening of the ramp. The surface shall extend joint to joint across the opening and shall be placed within 2-inches of the grade break at the back of curb at all points. See *KSD* 8-002 and 8-003.
- R. The largest slope measured on any part of a section of curb ramp shall be considered the slope for that entire portion of the curb ramp. The smallest value for length and width measured on a curb ramp shall be considered the measurement for that entire portion of the curb ramp.
- S. All slopes shall be measured using a calibrated digital level device. Discrepancies between the *Contractor's* measurements and the *City's* measurements shall be settled with a third digital level of the *City's* choosing. The *Applicant* may opt, at their expense, for a licensed surveyor to verify measurements.
- T. Directional ramps shall not be permitted unless otherwise approved by the *city engineer*.

8.06 Concrete Steps and Barrier-Free Access Ramps – Private Property

Steps shall only be used on private property and where an acceptable alternative *ADA* accessible access is available. Where used, concrete steps shall be approved by the *city engineer* and constructed in accordance with *KCRS* Detail 5-007 or another design acceptable to the *City* and consistent with the *WSDOT* Standard Specifications.

- A. Ramps used to provide barrier-free access shall have a maximum slope of 12:1 with a maximum rise of 30 inches between landings. Landings shall be a minimum of 5-feet by 5-feet.
- B. Handrails design, whether for steps or other applications, shall be provided consistent with *KCRS* Detail 5-007, the *WSDOT* Standard Specifications, and *ADA* Standard Guidelines.

8.07 Shoulders

Where *shoulders* are provided, they shall be delineated by a four-inch white painted edge line. Raised pavement markers for further delineation of the *shoulder* may be required at the discretion of the *city engineer*.

- A. Asphalt paved *shoulders* may only be used where approved by the *city engineer* on existing *roads* to provide for bicycle and pedestrian use.
- B. *Shoulders* may not be widened to provide on-street parking unless accompanied by a delineated adjacent 5-foot wide *walkway*. *Walkways* must meet *ADA* Standard Guidelines.
- C. Parking is not allowed on landscaped (lawn, topsoil, planting beds) *shoulders* or under tree canopies where tree roots may be damaged.
- D. *Shoulders* may be adjusted/alterd, as approved by the *city engineer*, to provide for safe operation of the *roadway*.
- E. Maintenance of gravel and/or vegetated *shoulders* is the responsibility of the adjacent private property owner per *KMC* 12.70.

8.08 Bicycle Facilities

Every effort shall be made to include safe bikeways on all new *roadways* and reconstruction projects unless bicyclists are prohibited by law from using the *roadway*. Design considerations for bikeways shall be assessed on a case-by-case basis but shall generally comply with the following:

- A. Projects shall include the bicycle facilities identified in the City Transportation Element of the Comprehensive Plan and the cross sections in Appendix B.
- B. The planning and design of bikeways in any category shall be in accordance with the *WSDOT* Design Manual and the *AASHTO* Guide for the Development of Bicycle Facilities, current edition.
- C. Bike lanes, where required, shall be a minimum of 5 feet in width with a striped 2-foot buffer unless otherwise approved by the *city engineer*.
- D. Pavement markings shall be used on bike lanes and paths per *KSD* 4-004 and in accordance with the *MUTCD* and the *AASHTO* Guide for the Development of Bicycle Facilities, current edition.
- E. The design of all signalized intersections shall address bicycle usage.

8.09 Fixed Objects

In addition to sound engineering judgment and analysis, the following minimum standards shall apply to all new or relocated placements of fixed, or non-break-away, objects within the public *right-of-way*. Existing *utilities* which are not in compliance with these *Standards* are not required to be relocated until such time that a repair, reconstruction, replacement, expansion, or relocation of the *utility* structure is planned. The following constraints on obstacle location will not apply to locations not accessible by moving vehicles, "breakaway" structures whose break-off resistance does not exceed that of a single 4 inches x 4 inches wood post or a 1.5-inch standard (hollow) iron pipe or to "breakaway" fire hydrants installed to manufacturer's specifications.

- A. Fixed objects along SR522, or any *roadway* with a posted speed limit exceeding 35 mph, shall comply with the Clear Zone requirements of Chapter 1600 of the *WSDOT* Design Manual.

- B. On *roadways* 35 mph or less, no new fixed object shall be placed with any portion of the object being closer than 2 feet from the face of curb.
 - 1. The City may require that a clear zone analysis be submitted and approved by the City prior to a permit being issued for a project which proposes a fixed object placed within 10 feet of the travel way for arterial and collector *roads*.
- C. On *roadways* 35 mph or less where no curb exists, no new fixed object shall be placed with any portion of the object being closer than 10 feet from the edge of pavement (or edge line if present).
- D. Fixed objects within the public *right-of-way* shall not be located closer than 5 feet to any *driveway* or private *road*.
- E. All clear zone measurements shall be taken from the edge of travel way. The edge of travel way shall be defined as the interior limits of any edge line where edge striping exists or the edge of pavement where edge striping does not exist, or face of curb.

8.10 Amenity Zone

All public *roads* constructed or improved under these *Standards* shall have an *Amenity Zone* per Chapter 6.

- A. *Amenity Zones* shall be no less than 4 feet in width.
- B. The *Amenity Zone* must be between the curb and the *sidewalk* unless otherwise approved by the *city engineer*.
- C. *Amenity Zones* are reserved for *street* light poles, *traffic signs*, *utilities*, mailboxes, landscaping, and other public amenities and these features should be located within the *Amenity Zone* to the maximum extent feasible.
- D. *Amenity Zones* may either be landscaped or concrete paved.

8.11 Illumination

Street illumination (*roadway* and pedestrian) is required for all new subdivision, commercial, or multifamily projects in accordance with Kenmore Municipal Code 17.20.107. *Street* illumination shall be provided on all new *roads* as required to meet these *Standards*. Illumination will also be required when a *road* intersects an arterial/collector, at all marked crossings, and other locations as determined by the *city engineer*. Illumination of *roadways* with turn channelization will include all lane tapers. Illumination shall meet with the following requirements:

- A. All new streetlights shall be LED compatible and shall provide a new LED bulb at the time of installation.
- B. The illumination system shall be designed per the requirements of the *IES* lighting standards.
 - 1. Pedestrian conflict levels shall be as follows (reference current Kenmore Land Use Plan):
 - i. Residential areas (R1-R10 zoned): *low*
 - ii. Residential areas (R12 and greater), Downtown Residential, Public/Private facilities, school walk routes, Business areas: *medium*
 - iii. Commercial areas, Urban Corridor: *high*
 - iv. In areas where two or more zoning areas intersect, the highest conflict level will prevail.
- C. *Applicants* shall evaluate existing lighting and design additional lighting as required per this section. Designs shall require approval from Puget Sound Energy's (PSE) lighting division on any submitted design. As an alternative, PSE may provide design services if available.
- D. Complete calculations for structural design, including anchor bolt details, shall be prepared by a Licensed PE.
- E. In all areas of the City except for those areas noted as standards 2-5 in Section 2.08F, the *street* lighting shall be installed using the following product types unless otherwise approved by the *city engineer*:
 - 1. Base Style: Sheridan
 - 2. Base Material: Concrete

3. Base Color: Powder coated black
4. Head Type: Traditionaire
5. Head Color: Powder coated black

8.12 Landscaping

Street trees and landscaping should be incorporated into the design of *road* improvements for all classifications of *roads*. Trees and shrubs shall be installed per *KSD 6-007*.

- A. Approved *street* trees are listed in Appendix C.
- B. The trees shall be:
 1. Located within the *Amenity Zones*, at center medians, and at back of *sidewalk* within the *street right-of-way* where feasible and when approved by the City,
 2. Located at back of *sidewalk* if no *Amenity Zone* exists,
 3. A species compatible with overhead *utility* lines,
 4. Maintained by the adjacent property owner,
 5. Spaced between 20 and 40 feet on-center depending upon the maximum growth width of the selected trees,
 6. Trees shall be spaced so that mature trees have a space of 1-5 feet between the widest branches,
 7. Placed a minimum of 10 feet on center from any *driveway* or intersection radius return on arterial/collector *roads* and 5 feet on center from any *driveway* or intersection radius return on a local *road*.
 8. Minimum of 2 inches diameter measured 1 foot from the top of the root ball.
- C. The trees may be spaced at irregular intervals to accommodate sight distance requirements for *driveways*, intersections, lighting, *utilities*, and/or Low Impact Design facilities.
- D. All trees adjacent to *walkways* shall have a 7-foot minimum branching height at time of planting. This may be reduced if tree bases are more than 5 feet from the back of *sidewalk* or in a center median.
- E. Minimum height clearance of existing trees adjacent to new *roads* shall be 13.5 feet above the finished *roadway* grade.
- F. Trees placed at the back of *sidewalk* (either in the *right-of-way* or on private property) that are within 10 feet from *sidewalk* shall include root barrier along the back of *sidewalk* edge per *KSD 6-007*.
- G. Commercial root barriers shall be required for all trees planted in *Amenity Zones*. Interlocking root barriers shall be placed at the edge of *sidewalks* and curbs, on center with the tree.
- H. Landscape areas within the *right-of-way* shall be treated with a minimum of 18 inches of 3-way mix topsoil and plantings applied as recommended for the species planted. The following plantings are acceptable:
 1. *Prunus laurocerasus* 'Mount Vernon' (Dwarf Mount Vernon English Laurel)
 2. *Cornus sericea* 'Kelseyi' (Kelsey Dogwood)
 3. *Berberis buxifolia* 'Nana' (Dwarf Boxleaf Barberry)
 4. *Berberis thunbergii* f. *atropurpurea* 'Bagatelle' (Dwarf Purpleleaf Japanese Barberry)
 5. *Hebe* 'Emerald Gem' or 'Hinerua'
 6. *Mahonia nervosa* (Cascade Oregon Grape)/*Mahonia repens* (Creeping Oregon Grape)
 7. *Spiraea japonica* 'Bullata'/'Little Princess'/'Shirobana'/'Walbuma'
 8. *Arctostaphylos uva-ursi* (Kinnikinnick)

9. *Rubus calycinoides* (Creeping Raspberry)
 10. *Thymus serpyllum* 'Magic Carpet' (Creeping Thyme)
 11. *Thymus pseudolanuginosus* (Woolly Thyme)
 12. *Narcissus* 'xx' (Daffodil)
 13. Grass (drought tolerant grasses with microclover)
 14. Additional plant species as approved by the Public Works Operations Manager.
- I. Landscaping between the *sidewalk* and the *right-of-way* line (or between the pavement edge and the right of way line where no *walkway* exists) shall consist of native plantings where practical. No plantings shall be placed within 10 feet of any pavement edge where no curb and gutter exist.
 - J. All landscaping shall be drought tolerant and suitable for the location proposed (growth height and width, light conditions, soils conditions, slopes, etc.)
 - K. Additional landscaping features are required for downtown areas as identified in Section 2.08.

8.13 Mailboxes

All projects which create new or additional residential, commercial, or industrial units must provide necessary improvements for mail delivery in accordance with the Bothell Postmaster. Mailboxes shall be per *KSD* 6-001, 6-004 or 6-005.

- A. All new mailboxes shall be neighborhood collection box units (NCBU) as approved by the Postmaster and installed at locations in accordance with the Postmaster requirements. An 8-foot wide pullout section shall be installed adjacent to the mailboxes on arterial and collector *streets* to accommodate mail truck delivery where feasible.
- B. Where existing single mailboxes exist adjacent to the project site, the *Applicant* shall coordinate with the Postmaster and adjacent mailbox owners to offer consolidation of their mailboxes into the new NCBU provided for the project/*development*. The NCBU provided shall accommodate all interested property owners plus a minimum of 1 parcel locker.
- C. A minimum 6-foot clearance for pedestrians must be maintained around all portions of any mailbox placed within a *sidewalk, shoulder, or walkway*.
- D. Where existing mailboxes will be impacted by required *street* improvements, temporary considerations must be made to maintain constant mail services to all addresses. Relocation (permanent or temporary) or replacement of the existing mailboxes shall be coordinated with the Postmaster, the respective residents/businesses, and City *inspector*.
- E. Mailboxes for projects located within the downtown areas identified in Figure 2.1 shall coordinate mail delivery without placing a new mailbox along the project frontage. Existing NCBU's shall be utilized where possible. Where existing NCBU's do not exist, new mail receptacles shall be placed on, within, or behind the building structure to the maximum extent feasible, subject to Postmaster approval.
- F. All mailboxes shall be maintained by the respective property owners. For NCBU's, maintenance and replacement language shall be included on final plat maps or maintenance covenants recorded on each individual property title.

8.14 Cut and Fill Slopes

Side slopes shall generally be constructed no steeper than 4H:1V on both fill slopes and cut slopes unless otherwise approved by the *city engineer*. Steeper slopes may be approved by the City upon showing that the steeper slopes, based on soil analyses, will be stable, or that appropriate mitigation measures are put in place.

- A. Side slopes shall be stabilized by grass sod or seeding or by other planting or surfacing materials acceptable to

the City.

- B. See Sections 8.15 and 8.16 for additional requirements.

8.15 Guardrail

All *roadway* side slopes shall be evaluated for the need of a guardrail in accordance with the *WSDOT* Design manual. The standards of this section shall apply to new construction only and shall not require existing locations to be retrofitted unless additional grading work is proposed. The following order of preference shall be taken in the *roadway* design:

- A. 4H:1V or flatter fill slopes adjacent to the *roadway* where the slope drop is greater than 6 feet.
- B. Provide 3H:1V or flatter fill slopes where 4H:1V slopes cannot be provided and the slope drop is greater than 6 feet.
- C. Provide 2H:1V or flatter fill slopes where 3H:1V or 4H:1V slopes cannot be provided and the slope drop is less than 6 feet. A soils report prepared by a Licensed PE (Geotechnical) will be required to verify slope stability.
- D. Evaluate need for barrier systems and provide design in conformance with *WSDOT* Standard Plans, Standard Specifications, and the *WSDOT* Design Manual.

8.16 Sidewalk Side Slopes

The standards of this section shall apply to new construction only and shall not require existing locations to be retrofitted unless additional grading work is proposed. Measurements from slopes are taken from the top of slope.

- A. Any side slope 4H:1V or flatter shall have a minimum of 1-foot buffer (<2% cross slope) between the edge of *sidewalk* and the start of the slope. If a 1-foot buffer cannot be maintained, a pedestrian curb/integral curb per *KSD* 8-012/*KSD* 8-010 will be required if the slope exceeds 6 feet in vertical drop.
- B. Any side slope steeper than 4H:1V but not exceeding 2H:1V shall have a minimum of 2-foot buffer (<2% cross slope) between the edge of *sidewalk* and the start of the slope. If the slope exceeds 6 feet in vertical drop, a pedestrian curb/Integral curb will be required.
- C. If a 2-foot buffer (<2% cross slope) cannot be maintained adjacent to side slopes steeper than 4H:1V, the following mitigation will be required:
 - 1. If a minimum of 1-foot buffer (<2% cross slope) can be maintained, a 6-inch pedestrian curb/integral curb is required. Vertical drops more than 6 feet will require a pedestrian railing per *KSD* 6-006.
 - 2. If a minimum of 1-foot buffer cannot be maintained, a pedestrian handrail is required.
- D. All slopes steeper than 2H:1V shall be considered a vertical drop. The following are required for a side slope exceeding 2H:1V:
 - 1. If the slope is within 3 feet of any *sidewalk*, a pedestrian railing or pedestrian curb/integral curb will be required. Vertical drops more than 18 inches will require a pedestrian railing.
 - 2. Side slopes that are a minimum of 3 feet from the edge of *sidewalk* shall require a 3-foot buffer (<2% cross slope).
- E. The City reserves the right to require handrail or fencing for any slope steeper than 4H:1V within or adjacent to the *right-of-way* which are considered a safety hazard as determine by the *city engineer*.
- F. A chain link fence in lieu of a pedestrian handrail may be installed if placed on private property.

8.17 Road Signs

Street signage is required for all new subdivision, commercial, *townhome*, or multifamily projects in accordance with Kenmore Municipal Code 17.20.105. *Road* signs shall comply with and be fabricated in accordance with the most recent edition of the *MUTCD*, the *WSDOT* Sign Fabrication Manual, and the *WSDOT* Standard Specifications.

- A. All public *roads* shall have a *street* name sign with white letters on a green background.
- B. All private *roads* shall have a *street* name sign with white letters on green over a sign of equal size with the words “Private Road” in white letters on a green background.
- C. Joint use *driveways* shall have address signing at the *driveway/road* entrance. Signage shall be placed within a tract or easement.
- D. Private *roads* shall have address signing at the *driveway/road* entrance where lots are not addressed to the accessing private *road*. Signage shall be placed within a tract or easement adjacent to the addressed *road*.
- E. *Road* sign placement shall be one sign with double sided printing, mounted to the side or top or of the post so all lettering is visible.
- F. All signs shall be placed on metal or wood posts and installed per *KSD* 6-002.
- G. All *road* signs shall be approved by the *city engineer* prior to placement.
- H. Additional signage may be required (historical name signage, warning signs, etc.) as directed by the City.
- I. Sign type, placement, and location on SR522 shall be approved on a case-by-case situation.

8.18 Survey Monuments

Survey monuments shall be required for all *roads* and placed/replaced per *RCW* Chapter 58 by a land surveyor registered in the State of Washington.

- A. Monuments shall conform to King County Standard Figure 5-019 and 5-020. Replace “King County” with “Kenmore” and be placed at all *road* intersections, points of curves in *roads*, and at such intermediate points as may be required by the *city engineer*.
- B. Plat monumentation shall comply with these *Standards on developments* such as subdivisions, residential, commercial, binding site plans, or any other construction that establish new public *roadways* or reconstructs existing public *roadways*. Monuments shall be set along the center of the *right-of-way* at the PVCs and PVTs of vertical curves and the PI of horizontal curves. When the PVI of the curve falls within the paved area of the *road*, a PVI monument may be set in lieu of setting monuments at the PVC and PVT.
- C. The monument case will be installed after the final course of surfacing has been placed on the *road*.
- D. All monuments shall be registered with the Washington State Department of Natural Resources and a copy of the registration provided to the City.
- E. All existing monuments, which are disturbed, lost, or destroyed during construction or surveying, shall be replaced by the *Applicant, Contractor, Builder, Developer, or utility* per *RCW* 58.09.130 and 58.04.015.
- F. Monuments shall be required on existing public *roads* only if the *road* receives a full width overlay or when a new *road* connects to the existing *road*.
- G. Monuments may not be required if an existing monument is located less than 100 feet from the required new location.

Chapter 9: Surface Treatments

9.01 Local Public and Private Roads

Local public and private *roads* shall be *HMA* with minimum pavement sections per *KSD 5-001*.

- A. The minimum pavement thickness for repairs, patches, replacements, extensions, and/or modifications within existing local and private *roads* shall be per *KSD 5-001*. Pavement shall be placed in layers not to exceed 2 inches in compacted thickness.
- B. Cross sections noted in *KSD 5-001* are only applicable for stable compacted subgrade constructed with suitable materials. Additional subgrade work may be necessary to create a stable subgrade.
- C. Alternative pavement (porous, pervious pavers, etc.) must be considered where feasible per the SWDM. Any alternative pavements proposed shall be designed by a Licensed PE and appropriately designed for the proposed materials and site conditions and shall be approved by the City prior to construction.
- D. Any proposed exception to these materials may be subject to soils strength testing and traffic loading analysis, and subject to City review and approval. At any time during construction, should a question on the suitability or placement of native soil or import materials exist, the *inspector* may require a geotechnical evaluation to address soil conditions. When required, the report shall be prepared, stamped, and signed by a Licensed PE (Geotechnical) and shall include an assessment of the site conditions and recommendations for corrective actions. A copy of maximum density curves and all associated compaction test reports shall be included with the report. All materials shall meet the requirements of the *WSDOT* Standard Specifications unless otherwise approved.

9.02 Arterial, Collector, and Industrial/Commercial Roads

Asphalt pavement designs for arterial, collector, Industrial/commercial *roads* shall be prepared by a Licensed PE in accordance with the current “*AASHTO* Guide for Design of Pavement Structures”.

- A. Flexible pavements shall be designed using a layered design analysis in accordance with the “*AASHTO* Guide for Design of Pavement Structures”.
- B. Pavements shall be designed to meet the minimum fire district load requirement of 75,000 lbs and a point load requirement of 70 psi.
- C. Materials shall meet *WSDOT* Standard Specifications and placed in layers not to exceed 2 inches in compacted thickness.
- D. The pavement design shall be based on soil parameters reflecting actual field or laboratory tests and a traffic loading analysis. A subsurface investigation shall be performed to provide information on any materials that would cause settlement, stability, or drainage problems. Soil used for the design analysis shall be representative of the native subgrade conditions. The traffic loading analysis shall include *traffic* volume, percentage growth rate, and axle loadings.
- E. Pavement design sections shall not be less than those required for local *roads*.
- F. The following design inputs shall be used for calculation of the pavement section:
 1. Pavement Design Life = 20 years
 2. Reliability (R) = 85%
 3. Overall Standard Deviation (S_0) = 0.50
 4. Design Serviceability Loss (ΔPSI) = 1.5
 5. Drainage Coefficient (m) ≤ 1.0

6. Layer Coefficients:

- i. Hot Mix Asphalt: ≤ 0.44
- ii. Crushed Surfacing: ≤ 0.14

7. Resilient Modulus (M_r):

- i. HMA: $M_r = 450,000$ psi
- ii. Crushed Surfacing Materials: $M_r = 28,000$ psi
- iii. Subgrade Soil: The subgrade M_r is based on actual field or laboratory tests. The subgrade M_r value used in the pavement design is not to exceed 15,000 psi.

G. Resilient modulus values for the subgrade soil shall be determined by Laboratory M_r tests or Falling Weight Deflectometer tests (FWD) performed in situ or default M_r values based on soil classification per the Unified Soil Classification System (USCS). The soil classification shall be based on laboratory testing of representative samples of subgrade soil.

H. USCS soil types shall be determined per ASTM D 2487. Default M_r values based on the USCS are as follows:

Class	M_r (psi)	USCS Soil Type
A	15,000	GW, GP, GW-GM, GP-GM
B	12,500	GM, SW, SP
C	10,000	SW-SM, SP-SM, SM-ML ¹
D	7,500	GW-GC, GP-GC, SW-SC, SP-SC, SM-ML ²
E	2,500	GC, GC-GM, SC, SC-SM, CL, CL-ML
F	Special Design ³	MH, CH, OL, OH, Peat

(1) Nonplastic

(2) Plastic

(3) Class F soils require a special design required to stabilize the subgrade and will be subject to review and approval by the City.

9.03 Requirements for Roads on Poor Subgrade

The minimum material thicknesses for local *roads* is not acceptable if there is any evidence of instability in the subgrade. This includes but is not limited to free water, swamp conditions, fine-grained or organic soil, slides, uneven settlement, or preexisting unsuitable fill material. If any of these characteristics are present, the soil shall be sampled, tested, and a pavement section designed in accordance with Section 9.02. Both the soils test report and the resulting pavement design will be subject to review and approval by the City.

- A. Cement treated soil may be used as an alternative to full depth replacement of poor subgrade. An evaluation performed by a Licensed PE (Geotechnical) is required to verify that cement treated soil is appropriate. If appropriate, a cement treated soil design shall be provided by a Licensed PE (Geotechnical) and approved by the City. Cement treated soil shall not prohibit the migration of ground water, infiltration of water, or prohibit excavation from a standard backhoe. Cement amendments may not exceed 5% of the dry unit weight of the soil to be treated.

9.04 Road Widening

- A. When an existing asphalt paved *road* is to be widened, the following requirements shall apply unless otherwise

approved by the *city engineer*.

1. The edge of the travel lane shall be sawcut to provide a clean, vertical edge for joining to the new asphalt.
 2. The existing asphalt may require removal as directed by the *inspector*, depending on the condition of the surface and as needed to control *surface water* flow.
 3. The existing *road* shall be planed a minimum of 2 inches, half-width throughout the widened area and the final asphalt lift applied across the widened and planed areas.
 4. All failures and cracking on *road* surfaces must be repaired prior to the overlay; the limits of the overlay will be based on the condition of existing pavement and the extent of required changes to the surfacing and channelization.
 5. If, for any reason, an overlay is not required, the joint shall be sealed with appropriate asphalt sealer.
 6. When the City determines that potential impacts from a *development* warrant subgrade repairs prior to the overlay, the *Applicant* must provide a geotechnical report that includes recommendations for repairing the subgrade.
 7. Sawcut lines and/or joints shall be located along the proposed lane edge or at the center of the *road* or lane.
- B. If an existing *shoulder*, private *driveway*, or private *roadway* is proposed to be incorporated into a future public *roadway*, the existing pavement shall be removed and replaced with a pavement section complying with these *Standards*. The responsibility for any *shoulder* material thickness improvement shall be considered part of the requirement for *roadway* widening.
1. Alternatively, a pavement evaluation can be performed. This evaluation shall analyze the structural capacity and determine any need for improvement. Designs based on these evaluations are subject to review and approval by the *city engineer*. Pavement thickness must meet the minimum requirements for that *road's* classification regardless of the evaluation results.
- C. Any widening of an existing *roadway*, either to add travel lanes or paved *shoulder*, shall have the same surfacing material and thickness as the adjacent existing *roadway*.

9.05 Overlays

Where overlays are performed, a full width 2-inch grind is required prior to the overlay to maintain finished surface elevations to the maximum extent feasible. Additional grinding may be required to meet drainage and ADA requirements or in cases where the existing pavement is in poor condition. Overlays without grinding require approval from the *city engineer* prior to being approved.

- A. Overlays shall require a minimum thickness of 2-inches of new asphalt material.
- B. Existing asphalt berms or other drainage features to control surface runoff shall be maintained or restored during the overlay unless otherwise approved by the *city engineer*.
- C. The existing crown or directional cross slope of a *roadway* shall be maintained after the overlay unless otherwise required by these *Standards*.
- D. Immediately following an overlay, the existing pavement markings shall be restored to original or as directed by the City *inspector*. Where pavement markings cannot be permanently restored in the same day as the overlay, temporary pavement markings shall be provided by the *Applicant* as directed by the City *inspector*. At the City's direction, existing pavement markings may be revised to match cross sections proposed in Appendix B or in the City's Comprehensive Plan. Prior to applying permanent pavement markings, all temporary pavement markings shall be removed. Temporary pavement markings shall be maintained as directed by the City *inspector* until such time as the permanent pavement markings are completed.

- E. Where overlays match existing *shoulders*, transitions of material similar to the adjacent surface material shall be provided to ensure safe pedestrian use and acceptable vehicle transitions.
- F. Where existing pavement is in poor condition as determined by the City, additional restoration such as additional grinding depths to localized full depth replacements may be required. Asphalt condition shall be determined at time of overlay.

9.06 Materials and Lay-Down Procedures

Materials and lay-down procedures shall be in accordance with *WSDOT* Standard Specifications and the requirements of this section.

- A. Prior to placement of any curb, gutter, *sidewalk*, or pavement section, a representative from an *AASHTO* accredited laboratory shall perform a compaction test on all backfill material placed in compacted lifts of 6 inches or more thick; the material shall be compacted to a minimum of 95% of the maximum dry density (ASTM D1557 modified) before any paving material is placed. Backfill material shall not be placed in compacted lifts greater than 1-foot thick. Backfill sections exceeding 6 inches but less than 4 square feet in area may be verified per Section 9.06B.
- B. For native undisturbed soils and backfill sections less than 6 inches in total compacted thickness, at the Licensed PE (Geotechnical) shall certify that backfill/undisturbed soils are firm and unyielding. This requirement may be waived at the *Inspector's* discretion.
- C. Asphalt pavement shall be placed in lifts no greater than 2 inches of compacted depth and compacted per *WSDOT* Standard Specifications to a minimum 92% compaction of the Rice value.
- D. Compaction reports shall be submitted to the *Inspector* prior to approval of any paved area.
- E. Compaction testing frequency shall be provided as noted in Section 4.06.
- F. During surfacing activities, *utility* and survey monument covers in *roadways* and *walkways* shall be protected and adjusted to the new finished grade.
- G. Asphalt shall not be placed on standing water or where subgrade conditions are such that compaction efforts might compromise the stability of the soil. Asphalt shall not be applied during rainfall or before any imminent storms that might damage the construction. The City will have the discretion as to whether the surface and materials are dry enough to proceed with asphalt placement.
- H. A proof roll and field investigation may be requested by the *inspector* to confirm the sub-grade is firm and unyielding. A single or dual axle dump truck, loaded to a minimum 90 percent maximum gross weight capacity, shall be used to perform the proof roll.
- I. Asphalt shall not be placed below temperatures noted in *WSDOT* Standard Specifications Section 5-04 unless otherwise approved by the *city engineer*.

9.07 Asphalt Surfacing Repairs

When repairing shallow holes and gouges in asphalt less than 1-inch deep, the surface must be thoroughly cleaned, and all loose or broken material must be removed from the hole/gouge. The bottom and edges of the hole/gouge shall be swabbed with asphalt tack. *HMA* shall then be placed into the hole or gouge and thoroughly tamped or rolled.

- A. For failures or holes/gouges between 1 and 2 inches in depth, the asphalt shall be sawcut such that the perimeter of cut encompasses a minimum of 2 feet beyond the perimeter of the entire failure, hole, or gouge. The existing pavement shall be a uniform square sawcut or removed. As an alternative, the pavement may be ground to the depth of the surrounding hole or damage. Asphalt tack coat shall be applied to all surfaces of existing pavement in the repair area.
- B. For failures or holes/gouges greater than 2 inches in depth, the asphalt shall be sawcut such that the minimum

repair area is three feet beyond the perimeter of repair. The existing pavement shall be sawcut or removed by a pavement grinder to the depth of the surrounding hole or damage. Asphalt for tack coat shall be applied to all surfaces of existing pavement in the repair area.

- C. *HMA* shall be placed in lifts of not greater than 2-inches compacted depth and shall be thoroughly and uniformly compacted to not less than 92 percent of the maximum density as determined by the Rice value.
- D. Edges shall be sealed in accordance with Section 5-04 of the *WSDOT* Standard Specifications.

9.08 Pavement Markings, Markers, and Pavement Tapers

Pavement markings and raised pavement markers shall be used to delineate channelization, transit lanes, bus zones, bike lanes, lane endings, crosswalks, longitudinal lines, fire hydrants, and any other location necessary to control or guide all users of the *roadway* system.

- A. Prior to any removal of pavement markings, existing markings shall be identified and temporarily staked along the City *Right-of-way* as needed to facilitate restoration of the channelization.
- B. Pavement markings shall conform to *KSD* 4-001 through 4-003 and *WSDOT* standard detail M-3.20-04.
- B. When removal of existing pavement markings is required, removal and compliance shall be done per *WSDOT* Standard Specification 8-22.3(6).
- C. Channelization and transitions shall be required when through *traffic* is diverted around a lane or obstacle, when connecting full-width *streets* with different cross sections, and when extending an existing *street* with a new cross section different than the existing one. Channelization shall also be required to redirect *traffic* back to its original alignment.
- D. Channelization plans and crosswalk locations shall be approved by the City prior to permit approval.
- E. Tapers: Tapers shall be installed per the *MUTCD*. Where the existing edge line of travel lane does not align with the inside gutter edge of newly installed curb, alternating white Type 1 and 2 raised pavement markers shall be installed at 5-foot centers to the end of the curb at a 25:1 taper. A reflective, 12-inch tall white tubular marker shall be installed at the edge of the curb.
- F. Crosswalks: Crosswalks shall be installed at all intersections controlled by *traffic* signals, flashing beacons, and other areas approved by the *city engineer*. See Section 7.07 for additional installation requirements.
- G. All pavement markings shall be laid out with spray paint and approved by the *Inspector* before they are installed.
- H. Pavement markings for channelization shall be reflectorized hot or cold applied plastic or paint per *WSDOT* Standard Specifications and the standard details. Extruded or sprayed markings shall be dressed with glass beads for initial reflectance. All materials shall have beads throughout to maintain reflectance as the material wears.
- I. Green pavement markings for bike lanes shall meet the following requirements:
 1. The daytime chromaticity coordinates for the color used for green colored pavement markings shall be as follows:

1		2		3		4	
X	Y	X	Y	X	Y	X	Y
0.230	0.754	0.266	0.500	0.367	0.500	0.444	0.555

The daytime luminance factor (Y) shall be at least 7, but no more than 35.

2. The nighttime chromaticity coordinates for the color used for green colored pavement markings shall be as follows:

1		2		3		4	
X	Y	X	Y	X	Y	X	Y
0.230	0.754	0.366	0.540	0.450	0.500	0.479	0.520

3. Green colored pavement markings shall be retroreflective.
4. Green paint or other marking materials applied to the *roadway* surface used to simulate a green colored pavement shall minimize loss of traction for bicyclists.
5. All paint shall be applied in three even coats unless otherwise noted on the Standard Details.

9.09 Curb Painting

At the request of adjacent property owners, curb painting by private parties is allowed if approved by the City. Curb painting shall comply with paint and application requirements as noted in *WSDOT* Standard Specifications 9-34 and as noted below:

- A. Curb paint color shall meet with AMS Standard 595 and be a commercially rated paint for outdoor concrete applications. Colors and allowed uses are as follows:
 1. Yellow [restricted parking only (RP)/No Parking (NP)]: color 33538 or close equivalent
 - i) Loading/unloading zones (RP)
 - ii) 5 feet either side of a *Driveway* (NP)
 2. Blue (restricted parking only): color 35180 or close equivalent
 - i) Americans with Disabilities Act (*ADA*) parking
- B. Curbing shall be painted with two full coats of paint. Paint may be applied by brush or spray.
- C. Curb paint shall be maintained by the *Applicant*, Homeowners Association, or entity(ies) that installed the paint. The City will not maintain or install curb painting. Each property owner/*Applicant* shall complete a letter of authorization prior to permit approval.
- D. Curb painting may require additional signage as directed by the *city engineer*.
- E. Requests for curb painting must obtain a beautification permit from the City.
- F. Per *KMC* 13.45.030 *Stormwater* Pollution Prevention Manual (SPPM), paint is considered an illicit discharge into *stormwater* facilities. No paint shall be allowed to discharge into the City’s storm drainage system. Left over paint shall be stored or disposed of in compliance with the SPPM at the property owner’s expense.

Curb painting on private *roads* and *driveways* for Fire Department use is required and shall be red color 11105 or close equivalent and applied as noted above and at the following locations where applicable.

- A. 15 feet either side of the fire hydrant
- B. Fire lane

Chapter 10: Drainage

10.01 General

Drainage facilities including pipe and ditch sizing, outfall protection, and temporary erosion and sediment control standards shall be designed consistent with Kenmore Municipal Code 13.35 and the adopted *Surface water* Design Manual (SWDM) including the amendments in Appendix F.

- A. No drainage from downspouts, splash blocks, sheet flow, etc. shall discharge across the surface of a *walkway* or *roadway*. “Through *sidewalk* drainage” is not allowed.
- B. Drainage facilities shall be placed and constructed per *KSD* 7-001 through 7-011, *WSDOT* Section B Standard Plans, and King County *Road* Standards (KRS) as appropriate. *KSD* and these *Standards* shall take precedence over any discrepancy with KRS and *WSDOT* standard plans.
- C. Materials, construction, and testing are specified in the *WSDOT* Standard Specifications. The *city engineer* may amend, delete, or add specifications or standard drawings. The *Development engineer* may require that additional details, specifications, or standards be developed; such items may be used freely by the City and incorporated into future revisions of the *Standards* and standard details.
- D. Where technical conflicts occur between the *Standards* and the SWDM, the more restrictive standard governs.
- E. See Section 7.05 for additional requirements.
- F. See Section 11.04 for installation and restoration requirements.

10.02 Road Ditches

Filling of existing ditches, including for additional on-street parking, is prohibited, except as noted below. Filling of ditches without City approval will result in monetary penalties per *KMC* 1.15 and 1.20 and will require corrective action up to and including restoration of the ditch and storm sewer testing/cleaning.

- A. Filling or elimination of *roadside* ditches shall only be permitted in the following cases:
 1. For one direct *driveway* access (including any existing) per parcel regardless of the parcel width as noted in Section 5.04D; or
 2. Construction of full frontage improvements (curb, gutter, *sidewalk*, etc);
or
 3. As part of a City *CIP* or maintenance project.

10.03 Storm Sewers and Culverts

Storm Sewer Pipes and Culverts shall be installed in accordance with Section 7 of the *WSDOT* Standard Specifications. All pipes and culverts shall flow directly to catch basin (via sidewalls), ditches, or swales and shall not directly discharge to gutters, *roadways*, *sidewalks*, or catch basin grates.

- A. Minimum pipe size within the public *right-of-way* or on any system to be maintained by the City shall be 12-inch diameter unless otherwise approved by the *city engineer*.
- B. The minimum slope on all pipe types and sizes is 0.5%, except those designed for flow control, water quality or *LID*(flow control BMPs) facilities.
- C. Pipe systems shall be designed in conformance with SWDM.
- D. Allowable pipe materials are identified in Appendix F.
- E. All storm sewer pipe and culverts placed under vehicle travel ways shall be covered by a minimum of two feet of cover. Where 2 feet of cover cannot be provided, ductile iron pipe must be used and must maintain 1-foot of minimum cover. For all other areas, 1-foot minimum cover is required. For existing concrete pipe, corrugated metal pipe, and pipe arches; pipe cover shall be per SWDM 4.2.1.1.
- F. Pipes which convey runoff over, across, through, or down a steep slope as define by *KMC*, must be a surface mounted pipe which is fused or mechanically restrained at the joint and which is anchored per the requirements of SWDM 4.2.1.
- G. All culverts which collect surface runoff from landscaped areas, ditches, or interceptor trenches without the use

of a catch basin or manhole, shall include a debris cage or trash rack at the upstream end.

- H. All new connections to an existing public underground drainage system shall be at a new or existing catch basin or manhole; no mid-span connections, tees, or “core-tapping” are permitted.
- I. Prior to substantial completion acceptance (but after all backfill and pavement are completed), all new storm sewer pipe including connected existing storm sewer pipe shall have a video inspection performed from structure to structure, unless otherwise approved by the *city engineer*. Video shall capture sidewalls and shall provide a close view of all joints. Final video capture shall be delivered to the City for review and acceptance.
- J. No *utility* shall be allowed to cross over/under another *utility* nor run parallel to any *utility* with less than a 2-foot offset unless otherwise approved by each respective *utility* owner.

10.04 Catch Basin Locations and Junctions

Catch basins shall be located along existing/proposed gutter lines and along drainage lines at edge of pavement or within *shoulders* if approved by the City. Catch basins shall not be located within the travel way outside of the gutter line or within *sidewalks*.

- A. Catch basins shall be spaced no greater than 150 feet for grades less than one percent, 200 feet for grades between 1 percent and 3 percent and 300 feet for grades 3 percent and greater.
- B. Catch basins rather than curb inlets shall be used to collect storm water from *road* surfaces.
- C. Type 2 catch basins shall be required where the depth to the invert of any pipe from the finished grade exceeds 5 feet.
- D. Manholes may be used in lieu of catch basins if they do not directly collect water from the surface. Manholes must be used if inverts are greater than 18 ft deep.
- E. Concentrated flow from adjacent property shall not discharge over the surface of *roadways, walkways, or shoulders*.
- F. Catch basins or manholes are required when joining differing types or sizes of pipes.
- G. See Section 7.05 for additional location requirements.

10.05 Frames, Grates, and Covers

Frames and grates/covers shall be per *KSD 7-007* through *7-010*.

- A. Metal castings for drainage structures shall not be dipped, painted, welded, plugged or repaired.
- B. Porosity in metal castings for drainage structures shall be considered a workmanship defect subject to rejection by the City.
- C. Castings for manhole rings shall be gray-iron conforming to the requirements of *AASHTO M 105, Grade 30B*. Covers shall be ductile iron conforming to *ASTM A 536, Grade 80-55-06*. Manhole rings and covers shall support a minimum loading of 25,000 pounds. All mating surfaces shall be machine finished to ensure a non-rocking fit.
- D. All manhole rings and covers shall be identified as specified in the *WSDOT Standard Specifications, Section 9-05.15*.
- E. Castings for metal frames for catch basins and inlets shall be cast steel, gray iron, or ductile iron as specified in Sections 9-06.8, 9-06.9, or 9-06.14 of the *WSDOT Standard Specifications*.
- F. Castings for metal frames for catch basins, inlets, grates and solid metal covers shall support a minimum loading of 25,000 pounds.
- G. Castings for grates and solid metal covers for catch basins and inlets shall be cast steel or ductile iron as specified in Sections 9-06.8 or 9-06.14 of the *WSDOT Standard Specifications*. The foundry name and material designation shall be embossed on the top of the grate. The material shall be identified as “CS” for cast steel and “DUC” or “DI” for ductile iron and shall be located near the manufacturer’s name.

- H. All metal covers for basins located in public *roadways* shall have “City of Kenmore” and other verbiage (as shown on *KSDs*) embossed on the top of the grate. Metal covers located on private property and maintained by private entities shall have “Private” embossed on the top of the grate.
- I. All grates and covers, including large grates placed over detention or water quality vaults, shall be seated properly to prevent rocking, including the replacement of existing covers with solid metal covers. Any warping or curvature of the metal that is not specified in the details or specifications shall be considered a workmanship defect subject to rejection by the City.
- J. Unless otherwise specified, vaned grates shall be used with standard frame in the traveled way, gutter, or paved *shoulder*. Diagonal slotted grates may be used in gravel/landscaped *shoulders* and on privately maintained systems. Solid lids shall be used within and *sidewalk* or crosswalk.
- K. At sag vertical curves, on the end of downgrade cul-de-sacs, or before intersections with a grade four percent or greater, an analysis shall be done to assure that typical catch basin grates will collect the surface runoff. To collect excessive volumes of runoff or protect against plugged grates and overflow situations, the City will require the use of through-curb inlet frames on vertical curbs. Where the through-curb inlets cannot be used, place a catch basin at the low point and two extra inlets located not greater than 0.1 foot above the low point grate within a distance of 25 feet.
- L. For new storm drains on existing rolled curb *roadways* use *KCRS* Figures 7-019 through 7-021.
- M. New catch basins that do not collect runoff shall use solid locking covers. Existing catch basins, which no longer collect runoff, shall have their frame and grates replaced with solid covers.
- N. All storm drain covers and grates within the *right-of-way* shall require locking lids and bolts. Additionally, all control structure and/or detention system storm drain covers shall be locking regardless of their location including hinged access points and large open grates.
- O. Trench drains may only be used outside of the *right-of-way* unless otherwise approved by the *city engineer*. At a minimum, trench drains shall have catch basins or yard drains at either end unless used as a *driveway* culvert. The maximum distance between catch basins or yard drains along a trench drain shall be 100 feet.

10.06 Erosion and Sediment Control

Provide erosion and sediment control as required in the SWDM or as specified by other guidelines and/or regulatory requirements.

- A. When using geotextile for temporary silt fences, the material shall be designed specifically for erosion control. It shall meet the requirements of *WSDOT* Standard Specifications, Section 9-33.2(1), Table 6.
- B. Fencing must be inspected regularly and after each significant storm event for damage. Any damaged, loose, or deteriorated fencing must be repaired/replaced within 24-hours. Sediment collected behind the fence must be removed so that this material does not push the fence over.
- C. All sites shall be permanently stabilized and all temporary erosion control measures removed prior to final approval.

10.07 Underground Structures

Where drainage structures are proposed below an area subject to *traffic* loading, including public *roads*, private *roads*, and parking lots, additional design consideration shall be applied.

- A. Large grates which do not utilize typical manhole or catch basin lids shall be located outside of the travel way, *sidewalk*, and any other public *walkways*.
- B. Maintenance access points and access openings shall be located outside of any vehicular travel lane. If it is not possible to locate outside of a vehicular travel lane, all access ports shall be located to allow maintenance work to be completed while maintaining at least one lane open to vehicle travel.

- C. All type 2 catch basins, manholes, and drainage vaults require access ladders and/or handholds per *KSD 7-005*. Ladders shall not exceed 6 inches beyond the edge of the frame and grate.
- D. Specialty structures or vaults subject to *traffic* loading shall be structurally designed by a Licensed PE (Structural) to support HS-25 loading standards and shall include a design for an additional 45,000 lbs. point load, applied on an 18"x18" area.
 - 1. Structural design plans shall be submitted to and approved by the City prior to construction of any such structure.
 - 2. Additional pavement markings or signage may be required at the discretion of the Fire Marshall to identify the structure location and alert emergency services of the structure below the surface.

10.08 Low Impact Development

Low Impact Development (*LID*) principles and Best Management Practices (BMPs) shall be designed and constructed in accordance with the SWDM (adopted *KMC 13.35*), including the design criteria, limitations and infeasibility criteria for each BMP, as applicable. Additionally, *LID* principles and BMPs shall adhere to the following:

- A. The *right-of-way* shall not be used for placement of *stormwater* facilities serving private property unless a City approved maintenance covenant is recorded onto the respective adjacent property title(s) or plat map.
- B. *LID* BMPs may be installed in the *right-of-way* for treatment or flow control of *stormwater* runoff from public roads. The facility shall comply with the city's clear zone requirements and Section 8.09 of these *Standards*.
- C. *LID* facilities on private property shall be located adjacent to the public *right-of-way* (plus any setback requirement outlined in the SWDM) unless a 10-foot wide minimum access *road* is constructed to the facility.
- D. BMP and bioretention system plantings in the *right-of-way* must be low growing species and mowable by City maintenance equipment (or as *contracted*), unless otherwise approved by the *city engineer*. See Section 8.12 for approved plantings.
- E. Rain gardens shall not be located in the public *right-of-way*, unless otherwise approved by the *city engineer*.
- F. Any *LID* BMP damaged by construction, maintenance activities, motor vehicles, or other activities, the party responsible shall restore the facility to an equivalent or better condition, as determined by the *city engineer*.
- G. Landscaped *Amenity Zones* adjacent to *sidewalk* may be utilized for full/limited infiltration for *sidewalks* if reliable, see Appendix F for additional requirements.
- H. A report outlining feasibility with supporting documentation of *LID* BMPs shall be provided to the City for each project.
- I. All *LID* features shall be maintained per the SWDM. Maintenance requirements shall be noted on the final Plat Map. Where no plat map exists, maintenance covenants shall be recorded on each property identifying maintenance requirements.

Chapter 11: Utilities

11.01 General

All *utility* work, including maintenance, performed within the City *right-of-way* shall require a *utility* permit.

- A. A design/construction agreement in lieu of obtaining a permit may be used under the following circumstance:
 - 1. When the *utility* work performed is related to a *utility* relocation or an undergrounding request for a City Capital Improvement Project; and
 - 2. When the *utility* work will be performed during the construction period of the Capital Improvement Project; and
 - 3. When the *utility* work will be wholly contained within the work limits of the Capital Improvement Project.
- B. *Utilities* to be located within existing and proposed *right-of-way* shall be constructed in accordance with current franchise and/or permit conditions and *KMC* 12.55, and in compliance with these *Standards*. In their use of the *right-of-way*, *utilities* will be given consideration in concert with the *traffic*-carrying requirements of the *road* which are, namely, to provide safe, efficient and convenient passage for motor vehicles, pedestrians, and other transportation uses. Aesthetics shall be a consideration.
- C. Underground installation of all *utilities* is required for new *developments*, for new *utilities* (including extensions of existing), and for all new and relocated *utility* services. All attempts shall be made to underground *utilities*. The following are exceptions to undergrounding:
 - 1. Aerial *utility* replacements if there are no changes in the connection locations (pole and meter).
 - 2. Transfer of existing *utilities* to new pole as part of pole replacement or City directed relocations; existing pole must be removed.
 - 3. New *utilities* that can be attached to existing poles.
 - 4. Preservation of significant trees per *KMC* 18.20.2730, as approved by the *city engineer*.
 - 5. Maintenance of *utilities*
 - 6. Other safety or environmentally sensitive situations as determined by the *city engineer*.
- D. All permits for new placement and replacement of existing *utility* poles and other *utility* structures above grade shall be accompanied by written certification from the *utility's* professional engineer licensed in the State of Washington or from an agent authorized by the *utility* to certify that the installations conform to these *Standards* and that the proposed work is in conformity with sound engineering principles relating to *street* safety and Section 8.09. Any *utility* pole requiring horizontal support shall be done by use of guy anchors; secondary poles (pole kickers) shall not be used.
- E. *Utilities* are subject to the *KMC* and policies relating to drainage, erosion/sedimentation control and sensitive areas as set forth in *KMC* 13.35 and the *Surface water* Design Manual.
- F. *Street* trees planted within the *right-of-way* along *streets* under the jurisdiction of the City of Kenmore shall not be removed or cut back where it damages the aesthetic quality of the tree. Such trimming, when required by power or telephone companies to safeguard their wires, shall be done in a manner that preserves the general appearance of the tree. Trees, shrubs and other plantings shall not be removed or trimmed where it damages the aesthetic appearance of the planting areas. (*KMC* 12.70.080).
- G. For new installations and relocations related to *City Projects*, *utilities* are responsible for surveying locations of new *utility* locations and providing as-built drawings with station and offset information (taken from the City's project stationing) to the City.
- H. Definitions:
 - a. Pothole cut – any cut 1 square foot or less.

- b. Boring/receiving pit cut – any cut 15 SF or less.
- c. Trench cut – any cut in the pavement that exceeds the maximum size for pothole or boring/receiving pit cuts.

11.02 Utility Locates

Utility locates are required per Section 4.10.

- A. *Utility* owners are responsible for locating their respective facilities. At the City’s request, the exact depth and location of underground facilities shall be potholed by the respective *utility*. Location of the *utility* shall be documented on a map with measured locations noted at a minimum of every 50 feet.
- B. *Utility* locate markings on *sidewalks*, curb ramps, and other non-*roadway* areas shall be removed within 10 calendar days of work completion. Removal shall not damage the finished surface.

11.03 Standard Utility Locations within the Right-of-Way

Utilities within the *right-of-way* on new *roads* or on *roads* where existing topography or other *utilities* are not in conflict shall be located as indicated below (cover depth is measured from the pipe zone, see *KSD 5-002*). Where existing *utilities* are in place, new *utilities* shall conform to these *Standards* as nearly as practicable and yet be compatible with the existing installations. Existing *utilities* may require relocation to conform to the other requirements identified in these *Standards*. Above ground *utilities* located within intersections shall be placed to avoid conflict with placement of curb ramps and *sidewalks*. Mains and service connections to all lots shall be completed prior to placing of surface materials. *Utilities* shall be located as follows where feasible:

- A. Gas and Water Lines:
 - 1. Located 3 to 7 feet off the *roadway* centerline.
 - 2. Designated Side of Centerline: GAS: South and West. WATER: North and East.
 - 3. Depth: 36 inches (3 feet) minimum cover from finished grade.
- B. Individual water service lines and side sewers shall:
 - 1. Be placed with minimum 36-inch (3 feet) cover from finished grade, ditch bottom or natural ground.
 - 2. Use *road right-of-way* only as necessary to make side connections.
 - 3. For any one connection, not extend more than 60 feet along or through the *right-of-way*, or the minimum width of the existing *right-of-way*.
 - 4. Locate water meter boxes, when placed or replaced, on the *right-of-way* line immediately adjacent to the property being served, unless otherwise approved by the *city engineer* and the water district.
- C. Sanitary Sewers: Locate no more than 3 feet off *roadway* centerline; depth 36-inch (3 feet) minimum cover from finished grade.
 - 1. Side Sewers shall be provided to all adjacent lots or parcels.
 - 2. Side Sewers shall be located per Northshore *Utility District* standards.
- D. Sanitary and water lines shall be separated in accordance with good engineering practice such as the Criteria for Sewage Work Design, Washington Department of Ecology, latest edition.
- E. Gravity systems, whether sanitary or storm drainage, shall have precedence over other systems in planning and installation except where a non-gravity sanitary or storm systems have already been installed under a previous approved permit and subject to applicable provisions of such permits or franchises.
- F. Electric *utilities*, telephone, cable TV, fiber optic conduit, other telecommunication: All new services and system mainlines including extensions and underground relocations shall be installed underground with 36-inch (3 feet) minimum cover, either side of *road* outside of the established travel lanes, a minimum of 2 feet from the edge

of pavement or curb, and at a depth compatible with other *utilities* and storm drains. The City may require additional clearance from the edge of pavement for *roads* proposed for widening for bike lanes or additional travel lanes. See Section 11.01 and 11.04 for undergrounding requirements. If undergrounding of new *utilities* is not feasible at locations where existing segments end or begin, new poles and other *utility* structures above grade shall conform to the following:

1. *Utility* poles or other approved essential *roadside* obstacles must comply with the clear-zone standards listed in Section 8.09.
 - i) Notwithstanding other provisions regarding pole locations described in these *Standards*, no pole shall be located so that it poses a hazard to the general public. *Utilities* shall place and replace poles with primary consideration given to public safety. Existing *utility* poles that do not comply with these *Standards* and are struck will be considered a hazard by the City and shall be mitigated by the *utility* in accordance with these *Standards*. Additionally, existing *utility* poles that comply with City *Standards* and are struck at least two times within the same five-year period shall be mitigated by the responsible *utility* as required by the *city engineer* and in accordance with these *Standards*.
2. Every effort shall be made to meet the *Standards* during emergency work or replacement of existing *utility* poles and other structures. After a pole has been replaced/relocated, the permittee is responsible for coordinating the transfers and pole removal. All *utilities* sharing that pole shall have a maximum of 180 days from the date the new pole is placed to relocate their facilities to the new pole and remove the old pole. Locations of poles shall also be compatible with *driveways*, intersections, and other *road* features (i.e., they shall not interfere with sight distances, *road* signing, *traffic* signals, culverts, etc.). To the extent possible, *utilities* shall share facilities so that a minimum number of poles are needed.
3. Where *road* uses leave insufficient overhang, anchor, and tree-trimming space for overhead *utilities*, additional easements and/or *right-of-way* may be required to accommodate the *utilities*. The costs associated with additional easements and/or *right-of-way* for this purpose shall be borne by the *Applicant* or other party initiating the improvement.
4. Where existing poles are in place, *utilities* shall consolidate onto the existing poles; no additional poles shall be installed.

11.04 Underground Installations

All hard surface *roadways* shall be jacked or bored except for storm drainage installations. Other exceptions will be considered on a case-by-case basis as needed.

- A. The underground systems shall not disturb existing survey monumentation unless there is no reasonable alternative. Disturbed monuments shall be corrected per WAC 332-120.
- B. When approved, the open cut shall be a neat-line cut made by saw cutting a straight continuous line. The current *WSDOT* Standard Specifications, Sections 7-08 and *KSD* detail 5-002 will generally apply unless otherwise stated.
 1. Trench sides shall be kept as nearly vertical as possible.
 2. Compaction and restoration must be done per *KSD* 5-002 and as detailed below and immediately after the trench is backfilled.
 3. After backfill and compaction, if a permanent repair cannot be completed during that same work period, an immediate cold mix patch shall be placed and maintained in a manner acceptable to the City.
 4. A permanent hot mix patch per section 9.07 shall be placed and sealed before permit expiration but within 30 calendar days.
 5. Cement concrete pavement shall be restored in accordance with Section 5-05.3(22) of the *WSDOT* Standard Specifications.

6. On crossings required to be opened to *traffic* prior to final trench restoration, steel plates shall be installed by the *Contractor* with cold patch wedges on all sides or as directed by the City.
- C. Backfill in *Roadway*: Trench backfill shall be crushed surfacing top course or base course meeting the requirements of Section 9-03.9(3) of the *WSDOT* Standard Specifications unless otherwise approved by the *city engineer*.
1. For excavations more than 4 feet deep (not including the pipe zone) on arterial and collector *roads* (2 feet on local *roads*), gravel borrow backfill may be approved by the *city engineer* for depths below 4 feet or 2 feet respectively.
 2. Native backfill in-lieu of gravel borrow may only be used upon approval of the material by the *Inspector*; the *Inspector* may require a Licensed PE (Geotechnical) to assess and certify the native material as suitable backfill.
 3. Backfill shall be placed and compacted mechanically at a maximum of 12-inch lifts to 95 percent of the maximum density as determined by ASTM D1557 Modified proctor test.
 4. Pipe Zone Bedding material for *utilities* other than Storm Drainage shall be Gravel Backfill for Pipe Zone Bedding, Gravel Backfill for Drains, or Gravel Backfill for Sand Drains per *WSDOT* Standard Specifications 9-03.12. Fluidized thermal backfill, controlled density fill (CDF), or other material may be used as approved by the City.
- D. All underground *utilities* shall have locator tape placed the full length of the underground run and placed between 1 and 2 feet directly above the respective *utility*.
- E. Pavement Restoration: Restoration of a trench within an asphalt pavement shall include *HMA* to the same thickness as the existing asphalt pavement or per Section 9, whichever is the greater.
1. Concrete pavement shall be restored consistent with Section 5-05 of the *WSDOT* Standard Specifications. Any concrete pavement *traffic* lane affected by the trenching shall have all affected panels fully replaced.
 2. Asphalt pavement shall be repaired depending on the impacts to the asphalt surface as directed below:
 - i. Any *roadway* surfaced (new construction or overlay) within the previous 5 years shall be restored with a 2-inch grind and overlay the full width of the *roadway* and shall extend a minimum of 20 feet beyond the cut limits.
 - ii. Cuts for pothole investigations, boring/receiving pits, for trenches which run perpendicular to the *roadway* which only impact one-side of the striped centerline, or for any cut which is entirely within limits of the *roadway shoulder* and is outside the existing or future travel way, shall neat cut the asphalt pavement 1 foot beyond the limits of the trench/pit and patch with new asphalt material. The edges of the new asphalt patch shall be sealed with asphalt binder (AR-4000 or approved equivalent).
 - iii. Trench cuts running predominantly parallel to the *roadway* which only impact one side of the striped centerline shall be repaired with a half-width 2-inch grind and overlay between the striped centerline and the edge of pavement or curb and shall extend a minimum of 20 feet beyond the cut limits. Pavement undisturbed by trenching activities shall be ground as needed to meet the requirements of a half-width overlay.
 - iv. Trench cuts of any type which impact more than one side of the striped centerline shall be repaired with a full-width 2-inch grind and overlay and shall extend a minimum of 20 feet beyond the cut limits. Pavement undisturbed by trenching activities shall be ground as needed to meet the requirements of a full-width overlay.
 - v. Any location where a trench cut or boring/receiving pit cut activity results in more than 2 separate cuts of any type within 100 feet of each other shall be interpreted as a singular cut with the overlay requirement as noted above.

- vi. Trench or boring/receiving pit cuts (with the exception of pothole investigations) within 100 feet of each other and occurring within a 5-year period by the same agency/*development* will be considered one activity and subject to pavement restoration requirements as outlined in this section.
 - vii. Pothole investigations within 50 feet of each other running parallel to the *road* and occurring within a 5-year period by the same agency/*development* will be considered one activity and subject to pavement restoration requirements as outlined in this section.
 - viii. Where a striped centerline does not exist, the "centerline" shall be at the crown line or as determined by the *city engineer*. In cases of superelevation or where the crown line is not at the approximate center of the paved *roadway*, the *city engineer* may consider the "centerline" to be the measured center of the paved *roadway*.
 - ix. Overlays shall be consistent with Section 9.05.
- F. Controlled Density Backfill: As an alternative to mechanical compaction, trench backfill above the bedding and below asphalt/concrete may be accomplished by use of controlled density backfill (CDF) in a design mixture according to Section 2-09.3(1) E of *WSDOT* Standard Specifications.
- 1. The *Contractor* shall provide a mix design in writing and the CDF shall not be placed until the City has reviewed the mix design and authorized its use.
 - 2. CDF shall meet the requirements of Section 6-02 of the *WSDOT* Standard Specifications and shall be accepted based on a Certificate of Compliance.
 - 3. The producer shall provide a Certificate of Compliance for each truckload of control density fill. The Certificate of Compliance shall verify that the delivered material is in compliance with the mix design.
- G. Backfill outside the *roadway* prism: Backfill outside the *roadway* prism shall be excavated material free of wood waste, debris, clods and/or any rocks exceeding six-inches in any dimension and meet compaction requirements.
- H. All work shall be inspected and tested per Chapter 4.06.

11.05 Inspection & Notification

The *Applicant* shall adhere to inspection notification requirements per the approved permit, existing franchise agreement, and Chapter 4.

11.06 Final Adjustments

All *utility* covers, including drainage, which are located on proposed asphalt *roadways*, shall be temporarily placed at subgrade elevation prior to placing crushed surfacing material.

- A. Final adjustment of all covers and access entries shall be made following final paving by:
- 1. Sawcutting or neat-line jack hammering of the pavement around lids and covers. Opening should not be larger than 12 inches beyond the radius of the cover.
 - 2. Removing base material, surfacing course, and frame; adding risers; replacing frame and cover no higher than finished grade of pavement and no lower than one-half inch below the pavement.
 - 3. Filling and mechanically compacting around the structure and frame with crushed surfacing material, or asphalt treated base, or placing in 5-inch minimum thickness of cement concrete Class 4000 to within 3 inches of the top.
 - 4. Filling the remaining 3 inches with *HMA* compacted and sealed to provide a dense, uniform surface.
 - 5. Final adjustment of all covers and access entries shall be completed prior to permit expiration but within 30 days of final paving.
 - 6. Final adjustments may be done prior to the final pavement lift utilizing *HMA* and paper joints around

covers, as approved by the *Inspector*.

11.07 Microtrenching

Microtrenching shall mean a narrow open excavation trench for the purpose of installing a subsurface pipe or conduit. Microtrenching as an alternative to boring may be considered for telecommunication, fiber and cable installations at the discretion of the *city engineer*. The following minimum standards will apply to microtrenching:

- A. The trench shall be between 1 and 2 inches in width or as otherwise approved by the *city engineer*.
- B. For local *roads*: conduit/conductor shall be installed at depth of 12 inches below the established finished grade of the existing paved surface.
- C. For arterial and collector *roads*: conduit/conductor shall be installed at a depth of 16-18 inches below the finished grade of the existing paved surface.
- D. Microtrench shall be a minimum of 2 feet from any existing curb/gutter.
- E. A 2-inch deep, 24-inch wide (centered on the proposed microtrench) pavement grind shall be made the full length of the trench.
- F. Microtrenching is allowed within *walkways*, *curb/gutter*, or concrete paved *roads*, however, panel/segments from joint to joint must be removed and replaced; no sawcutting of concrete will be allowed.
- G. Microtrench shall be backfilled with water compacted sand to the bottom of the ground pavement layer followed with hot mix asphalt (*HMA*). Cement/sand slurry reaching 2500 psi may be used in lieu of compacted sand.
- H. *HMA* patch shall be installed and finished per Section 9.07.

[END]



APPENDIX A

ROAD CLASSIFICATIONS

City of Kenmore

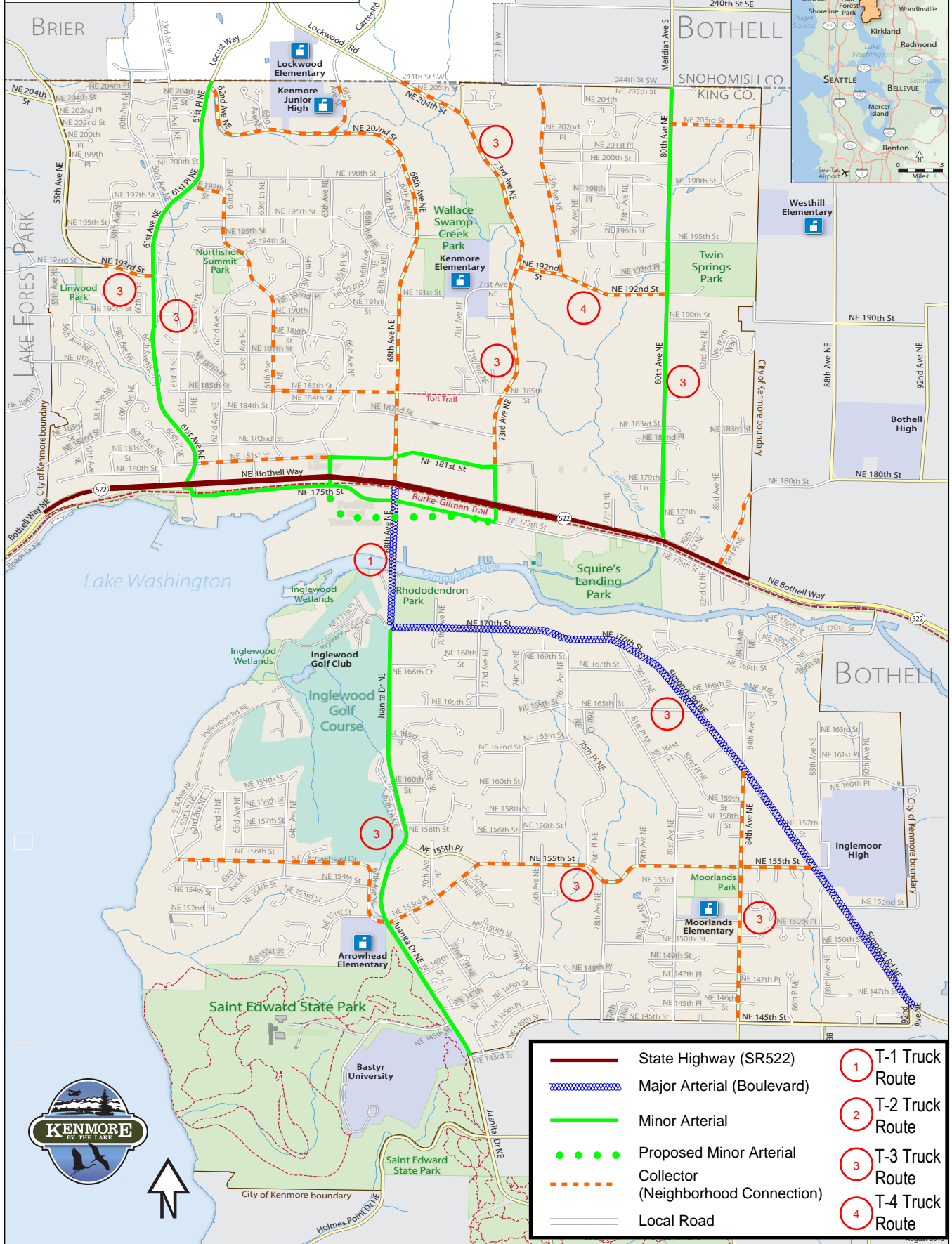

CITY OF KENMORE

ENGINEERING DEPARTMENT
(425) 398-8900

Road Classifications

FIGURE A-1

NOT TO SCALE

Date: 5/20/2021



APPENDIX B

ROAD SECTIONS

68th Avenue NE
(SR522 to 181st St)

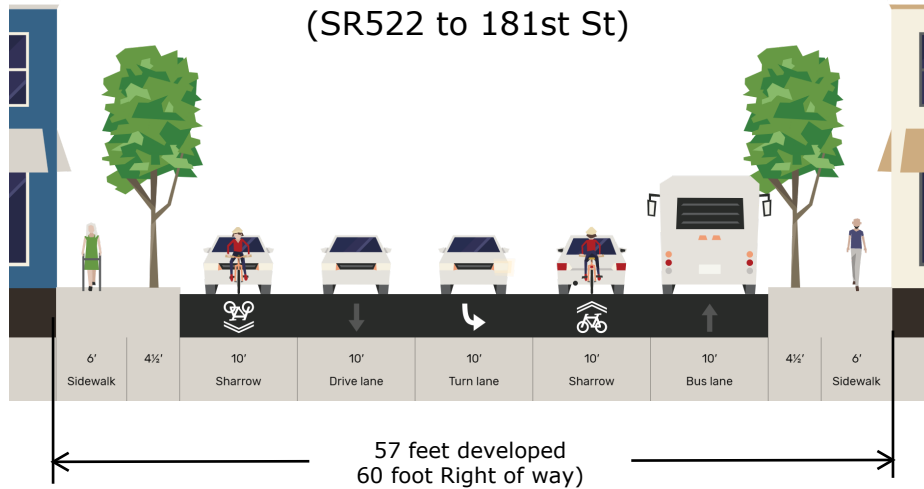

68th Avenue NE
(181st St to 185th St)

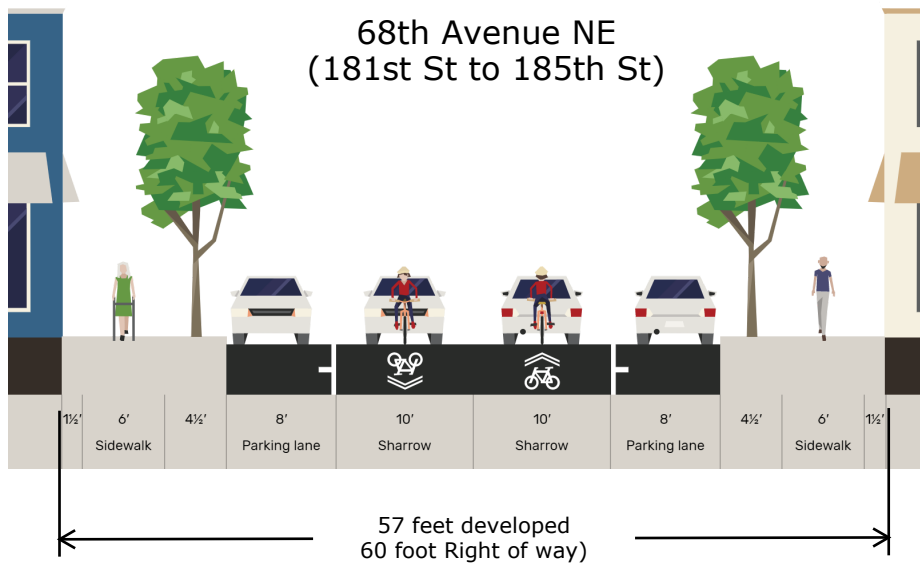

68th Avenue NE
(185th St to 202nd Ave)
NE 202nd St
(68th Ave to 62nd Ave)
62nd Avenue NE
(202nd St to 61st Pl)

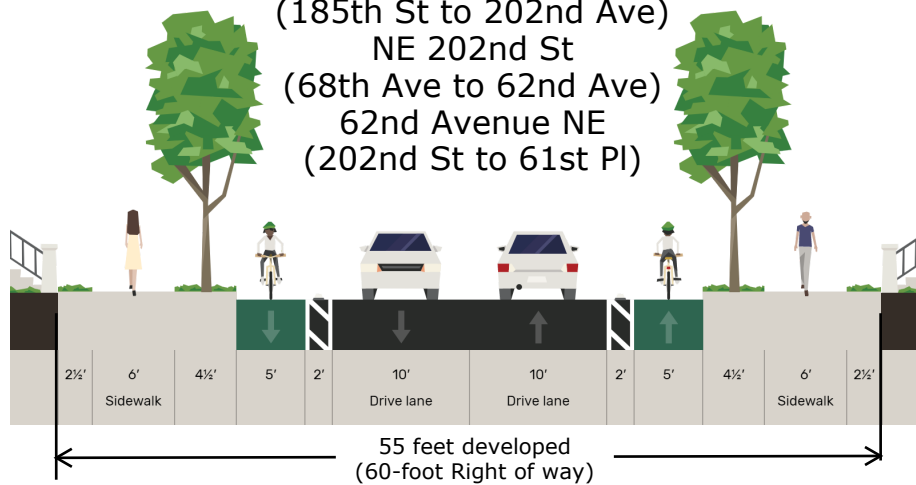

CITY OF KENMORE

ENGINEERING DEPARTMENT
(425) 398-8900

**68th Ave NE / NE 202nd St
Cross Section**

**FIGURE B-1
NOT TO SCALE**

Date: 05/12/2023

61st Avenue NE/61st Place NE
(190th St to 62nd Ave)**

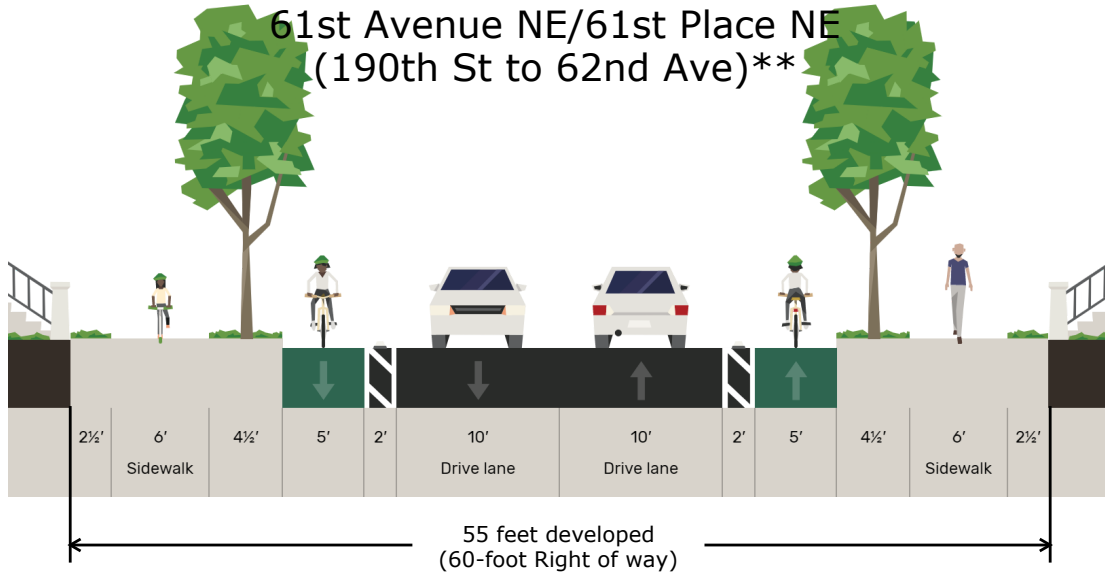

61st Avenue NE
(~184th St to 190th St)**

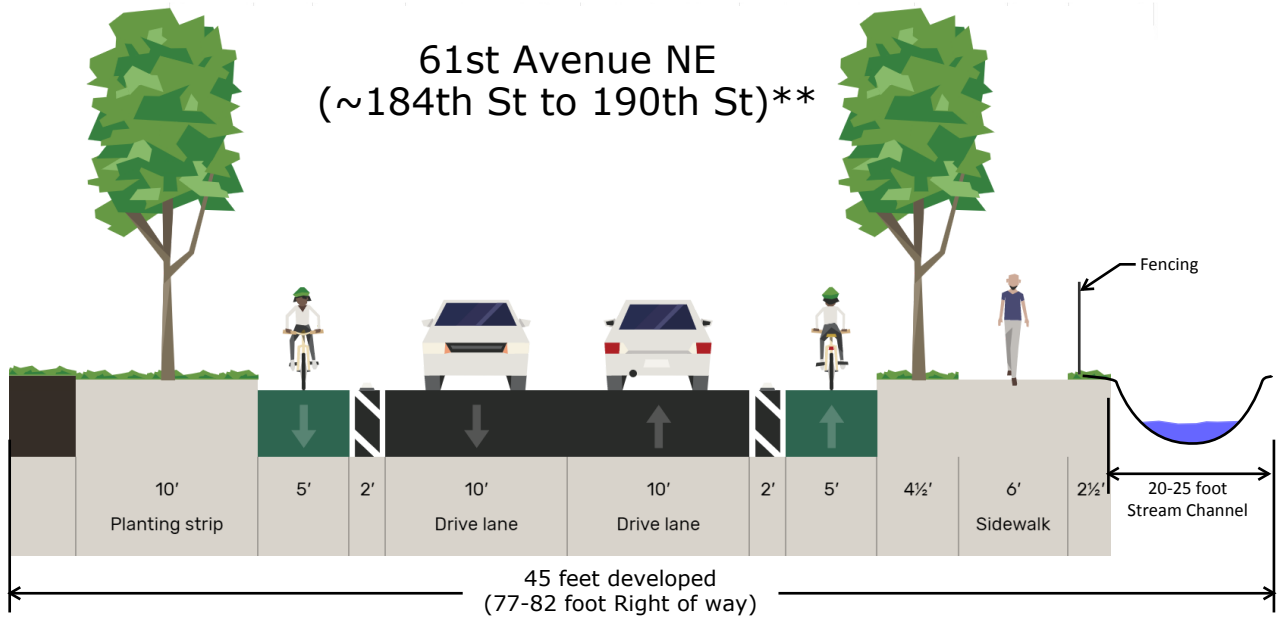

61st Avenue NE
(181st St to ~184th St)*

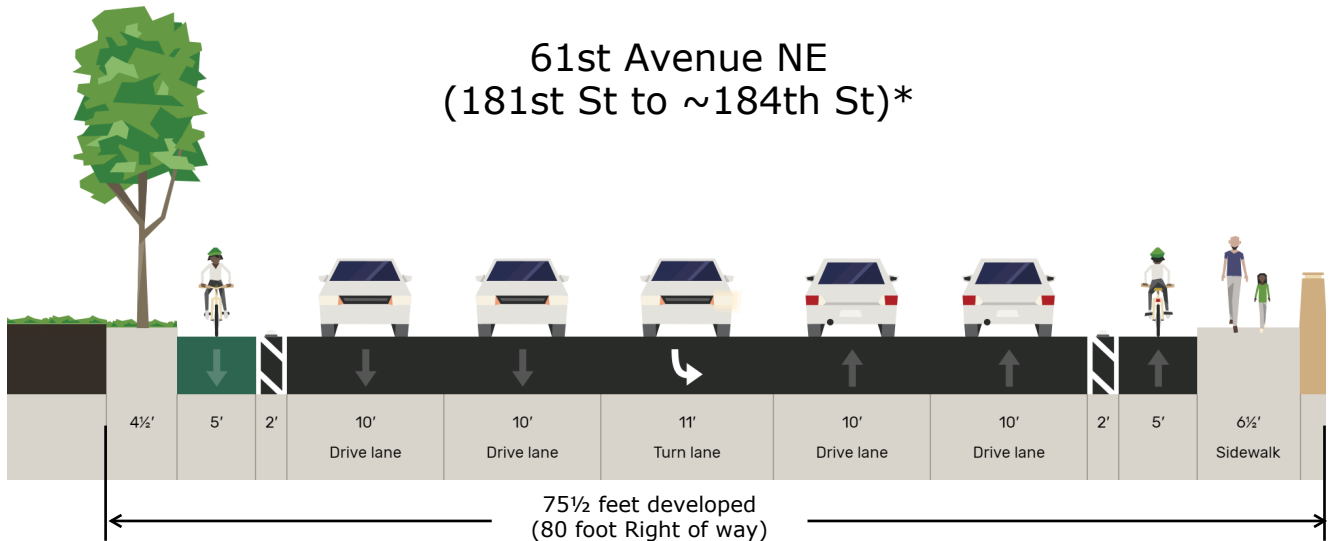

* Cross section transitions from 5 lane to 2 lane with bike lane configuration
** additional 11-foot wide left turn lane required at the 190th and 193rd intersections (NB and SB)



CITY OF KENMORE

ENGINEERING DEPARTMENT
(425) 398-8900

**61st Ave NE / 61st PI NE
Cross Section**

**FIGURE B-2
NOT TO SCALE**

Date: 05/11/2023

80th Avenue NE
(SR522 to 177th PI)

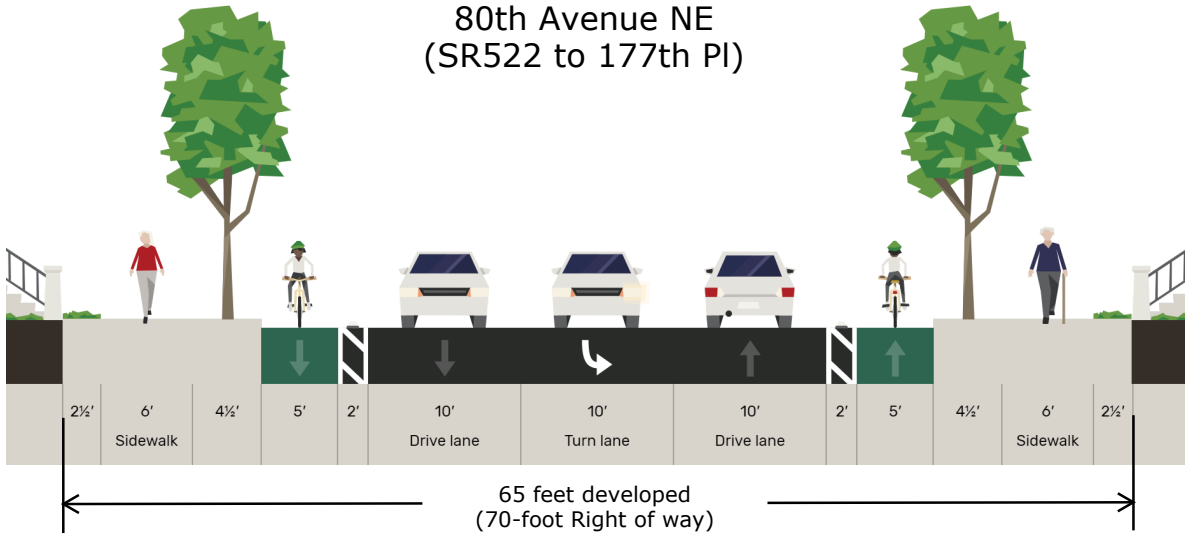

80th Avenue NE
(177th PI to 193rd PI)
(198th St to 205th St)

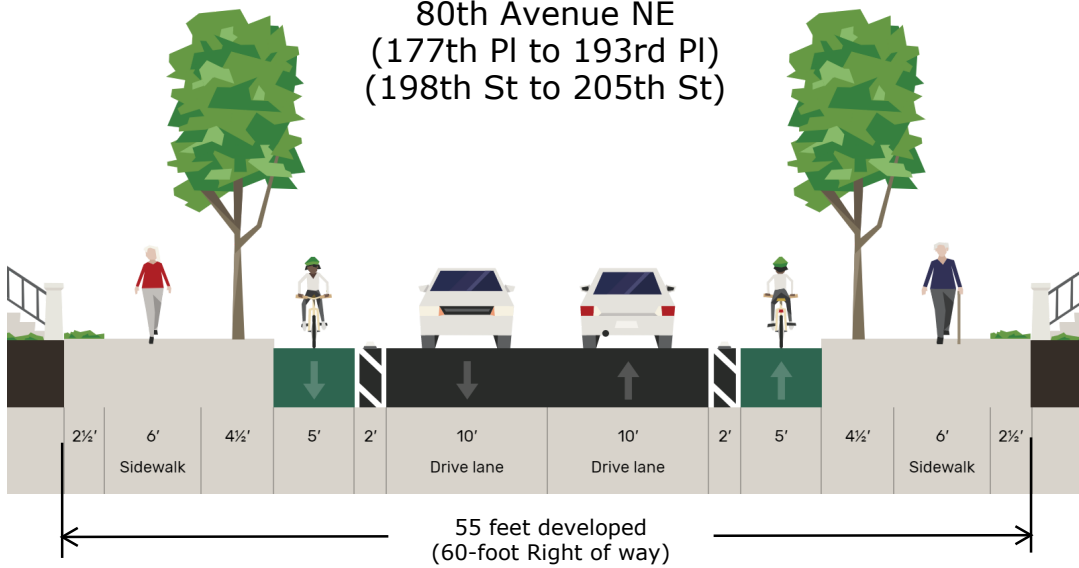

80th Avenue NE
(193rd PI to 198th St)

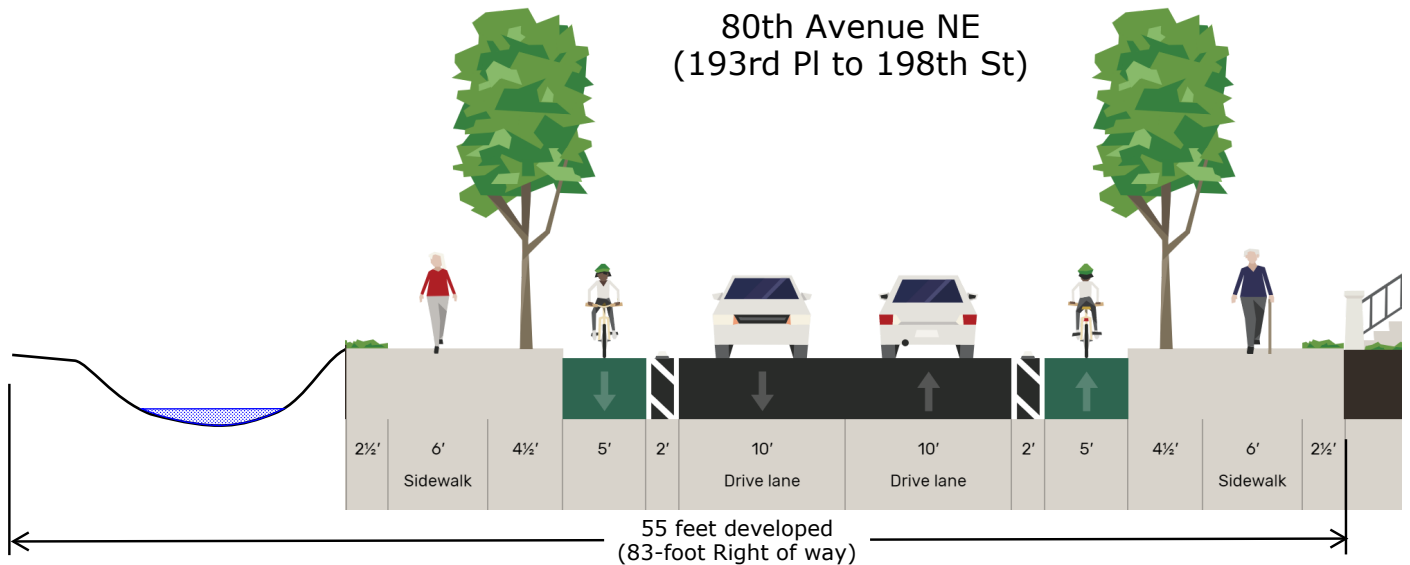

CITY OF KENMORE

ENGINEERING DEPARTMENT
(425) 398-8900

**80th Ave NE
Cross Section**

**FIGURE B-3
NOT TO SCALE**

Date: 05/15/2023

73rd Avenue NE
(175th to SR522)

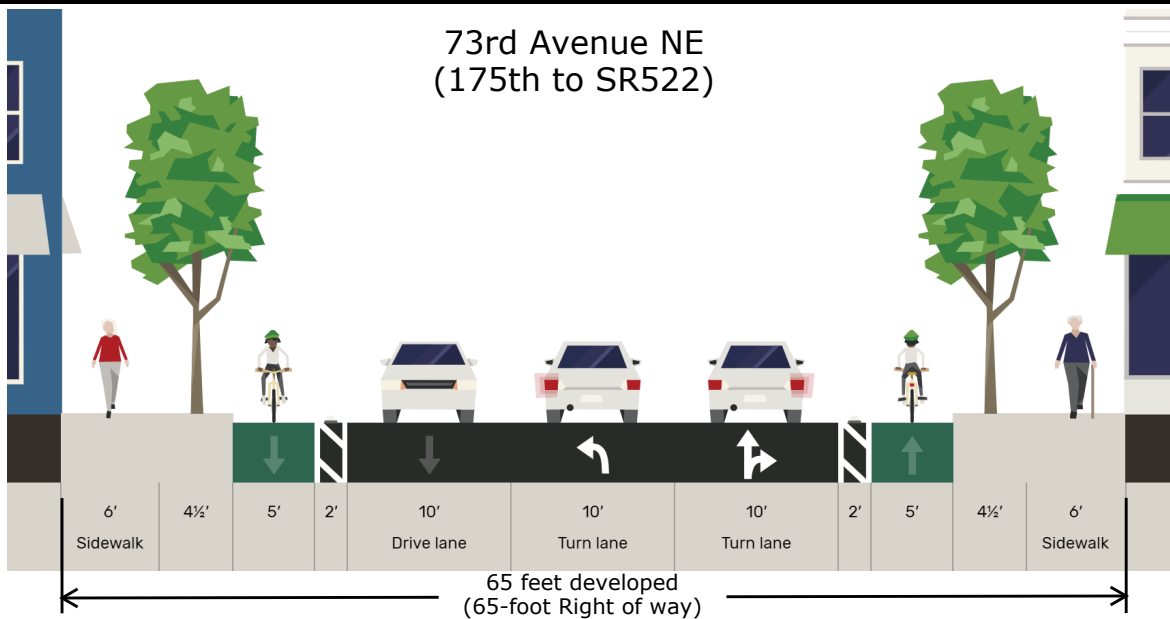

73rd Avenue NE
(SR522 to 181st St)

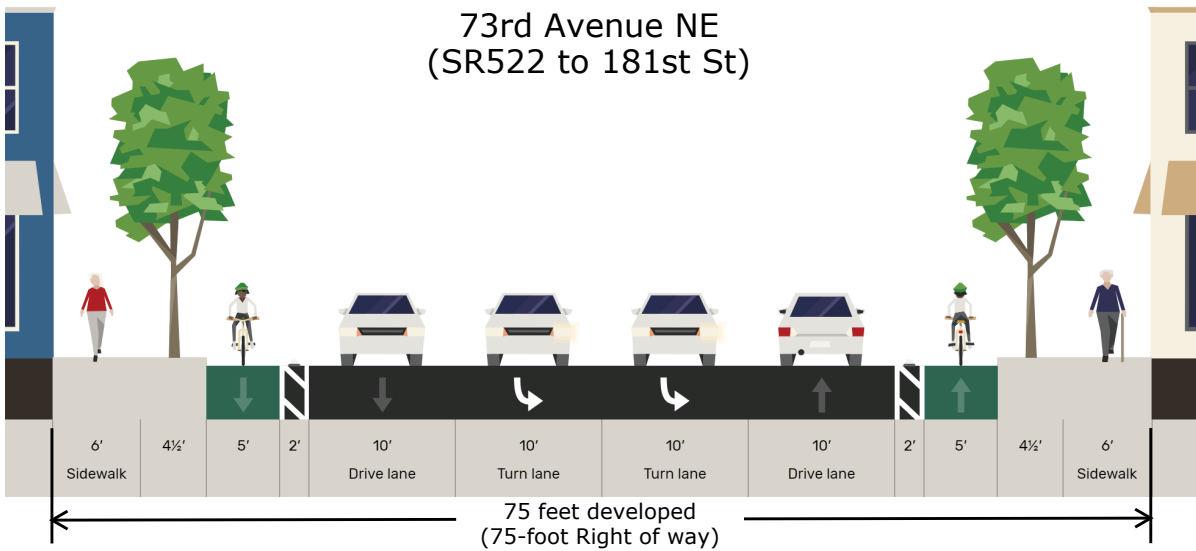

73rd Avenue NE
(181st St to 205th St)

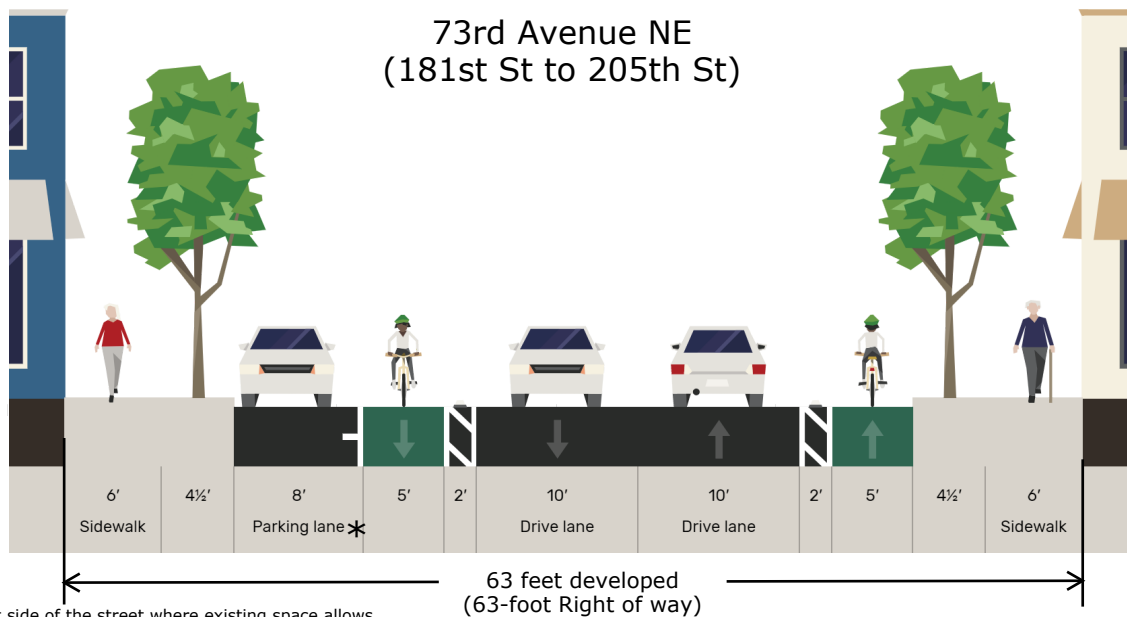

* Parking on the west side of the street where existing space allows



CITY OF KENMORE

ENGINEERING DEPARTMENT
(425) 398-8900

**73rd Ave NE
Cross Section**

**FIGURE B-4
NOT TO SCALE**

Date: 05/15/2023

NE 153rd Pl
(Juanita Dr to 70th Ave)

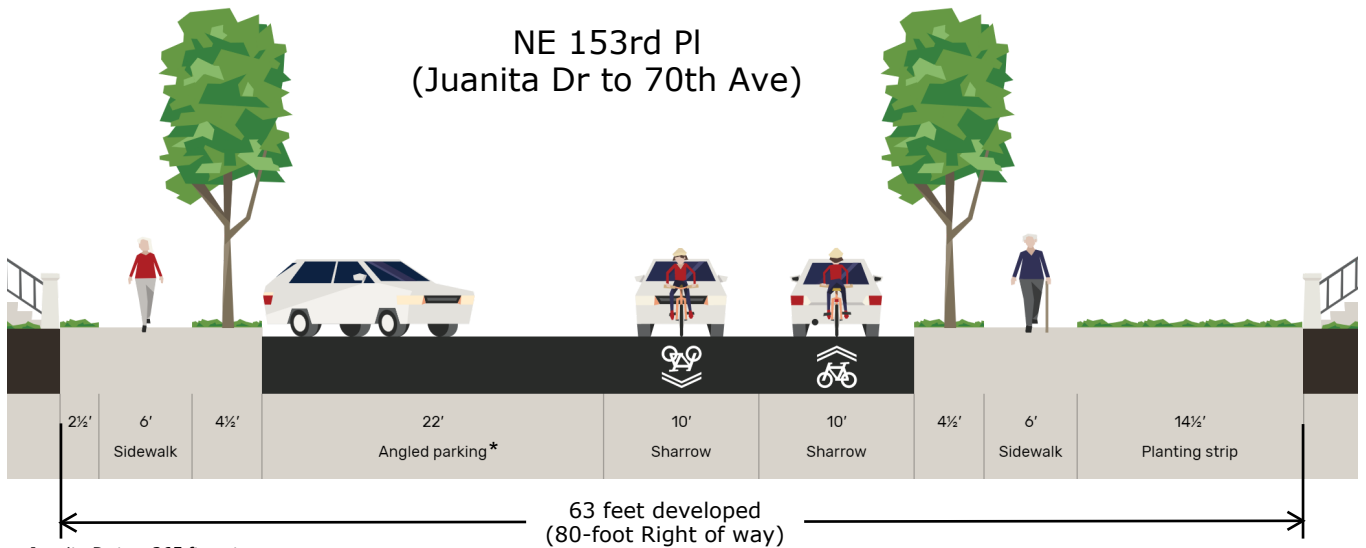

* Only from Juanita Dr to ~265 ft east

NE 153rd Pl/NE 155th St
(70th Ave to 84th Ave)

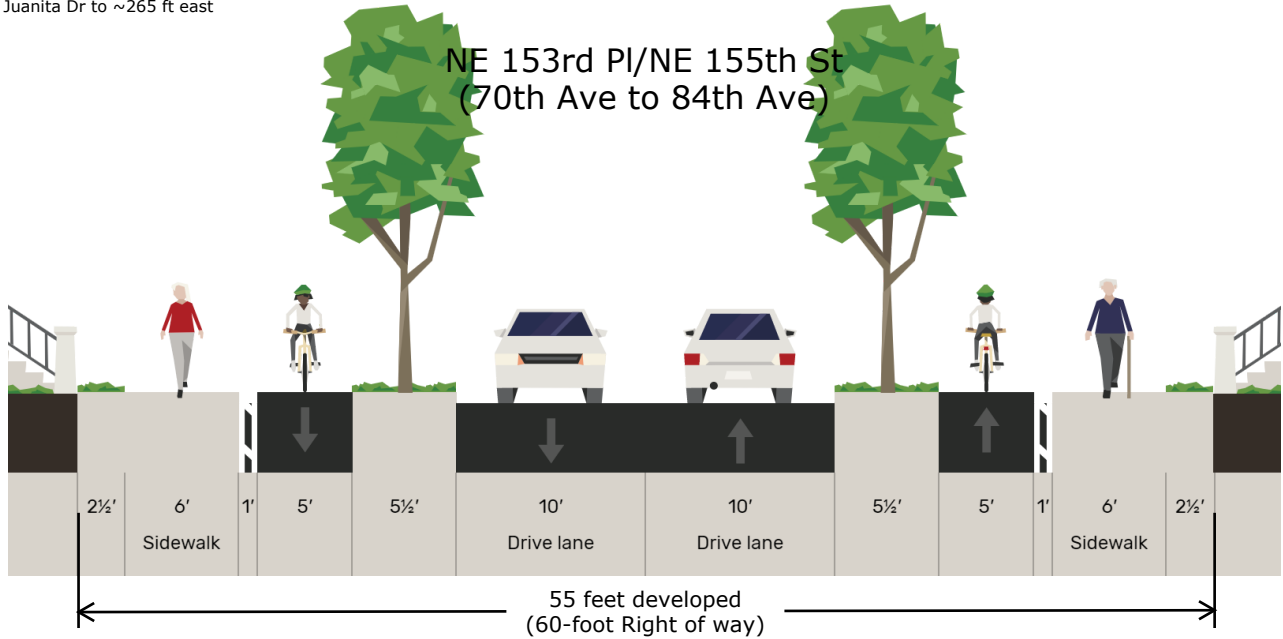

NE 155th St
(84th Ave to Simonds Rd)

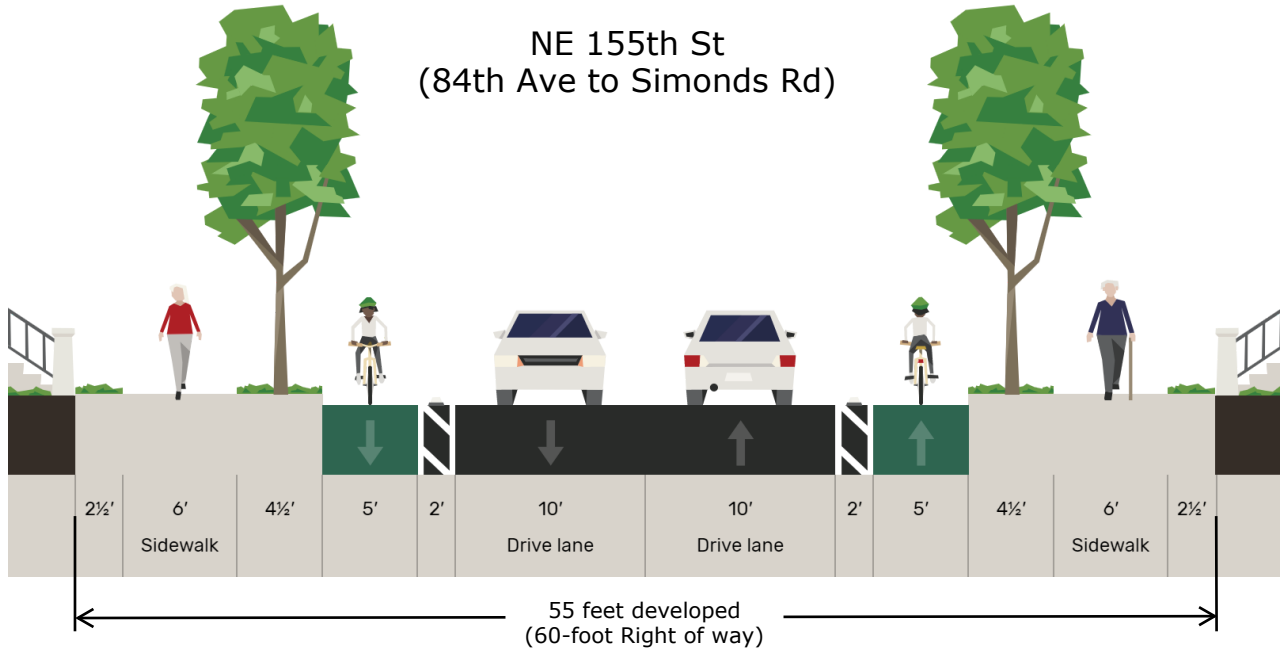

CITY OF KENMORE

ENGINEERING DEPARTMENT
(425) 398-8900

**NE 153rd Pl/ NE 155th St
Cross Section**

**FIGURE B-5
NOT TO SCALE**

Date: 05/15/2023

Simonds Rd
(75th Ave to 92nd Ave)
NE 170th St
(68th Ave to 75th Ave)

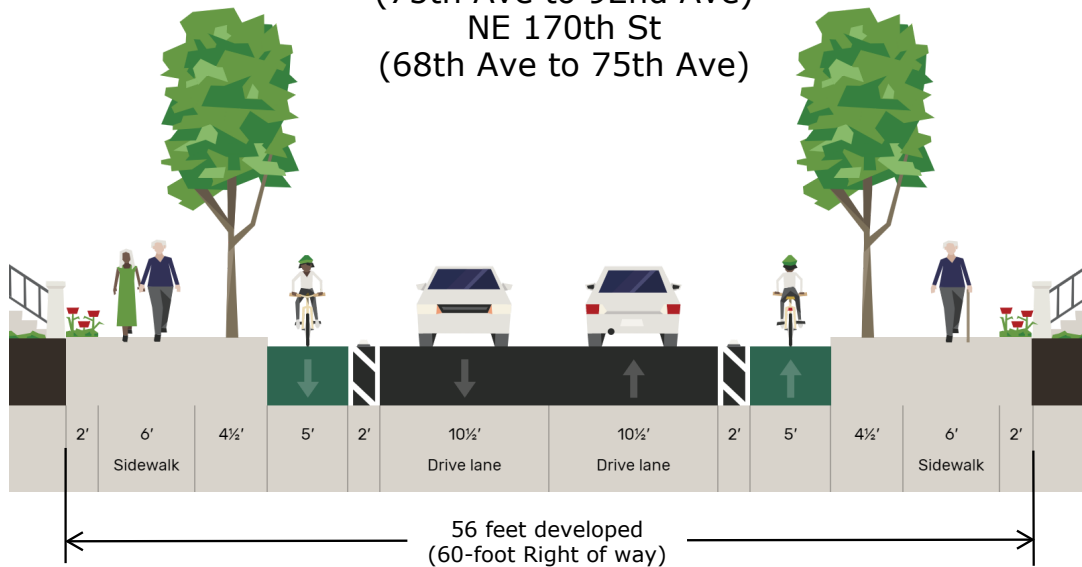

Simonds Rd
(NE 155th & NE 151st Intersections)

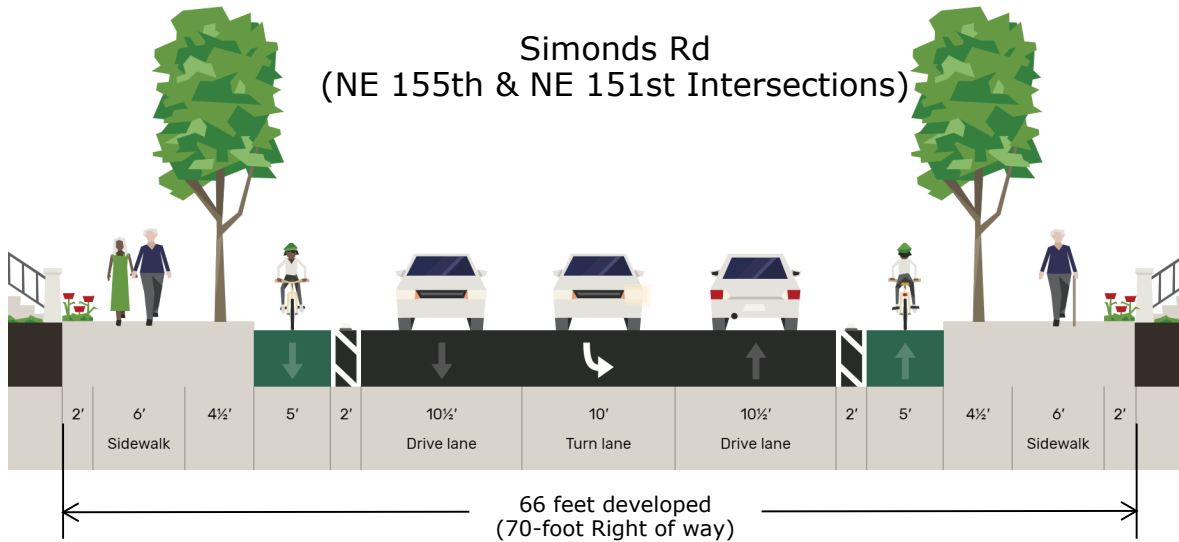

NE 170th St
(68th/Juanita Dr Intersection)

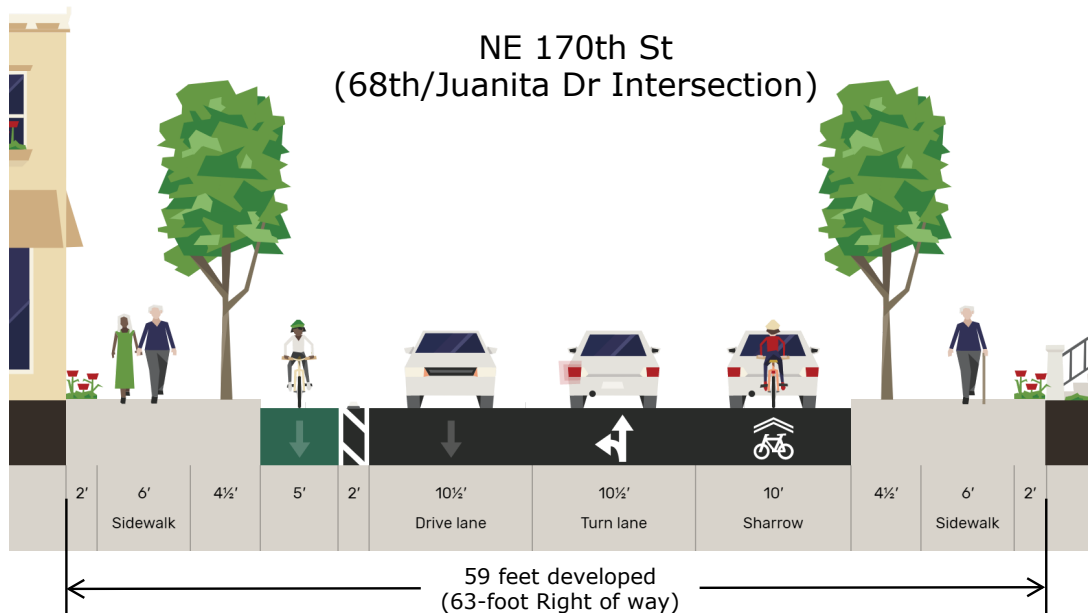

CITY OF KENMORE

ENGINEERING DEPARTMENT
(425) 398-8900

**Simonds Rd/NE 170th St
Cross Section**

FIGURE B-6

NOT TO SCALE

Date: 05/22/2023

Juanita Drive (NE 143rd to NE 170th)

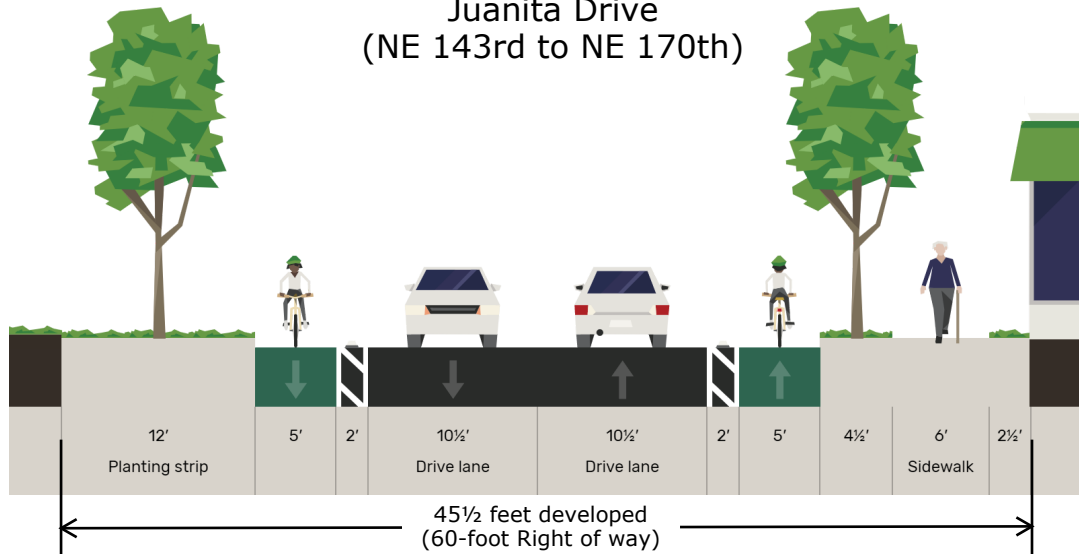

Juanita Drive (Intersections and Approaches)

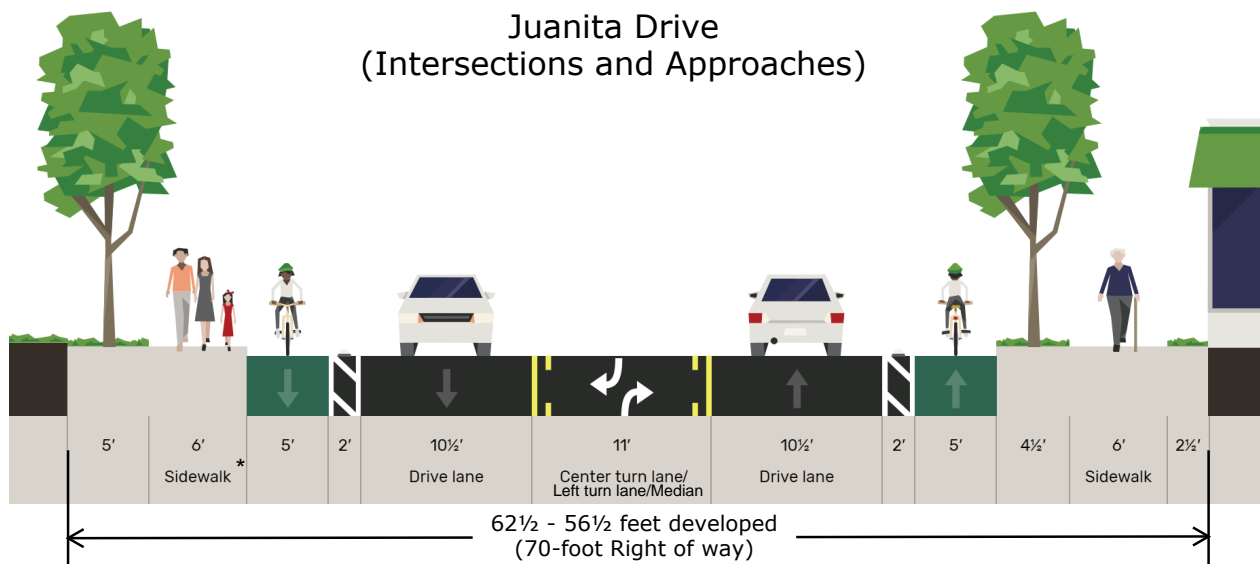

* Sidewalk at select intersections and becomes planting zone within approach areas

Juanita Drive (NE 170th Intersection)

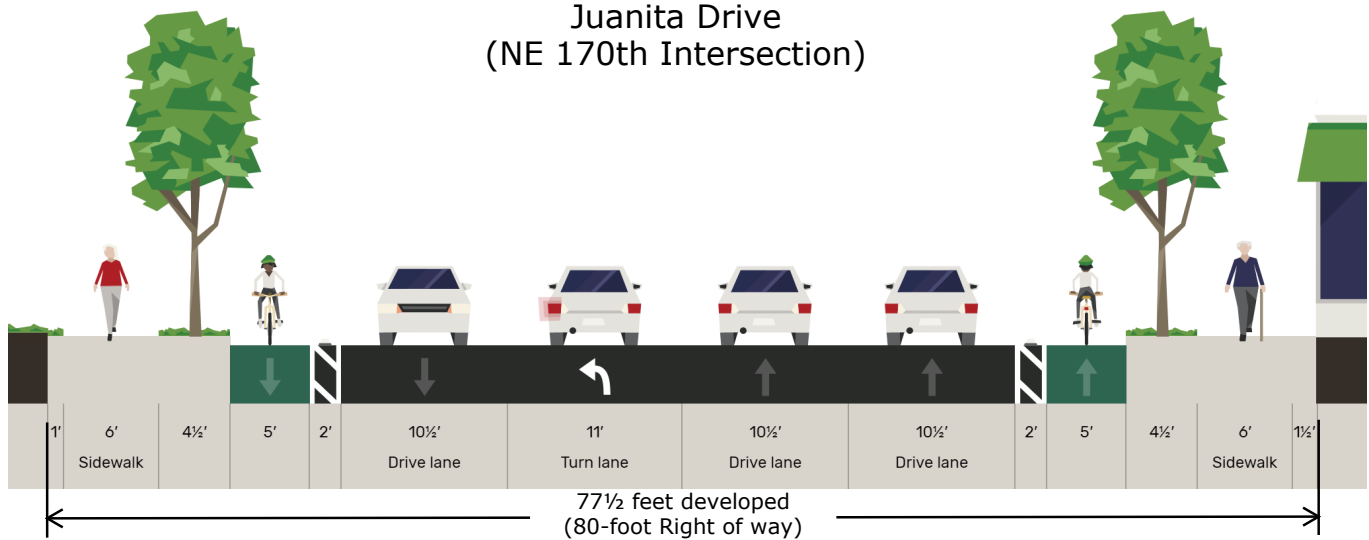

CITY OF KENMORE

ENGINEERING DEPARTMENT
(425) 398-8900

**Juanita Drive
Cross Section**

**FIGURE B-7
NOT TO SCALE**

Date: 05/15/2023

NE 192nd St
(73rd Ave to 80th Ave)

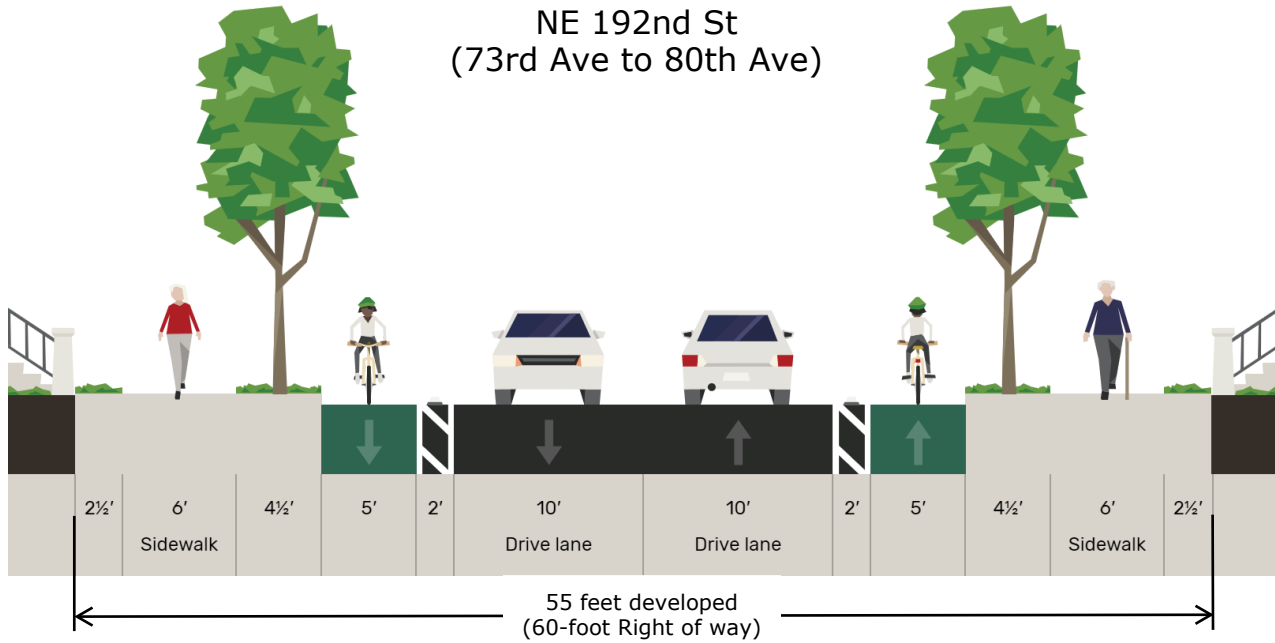

CITY OF KENMORE

ENGINEERING DEPARTMENT
(425) 398-8900

**NE 192nd St
Cross Section**

**FIGURE B-8
NOT TO SCALE**

Date: 05/15/2023

NE 181st St
(67th Ave to 68th Ave)

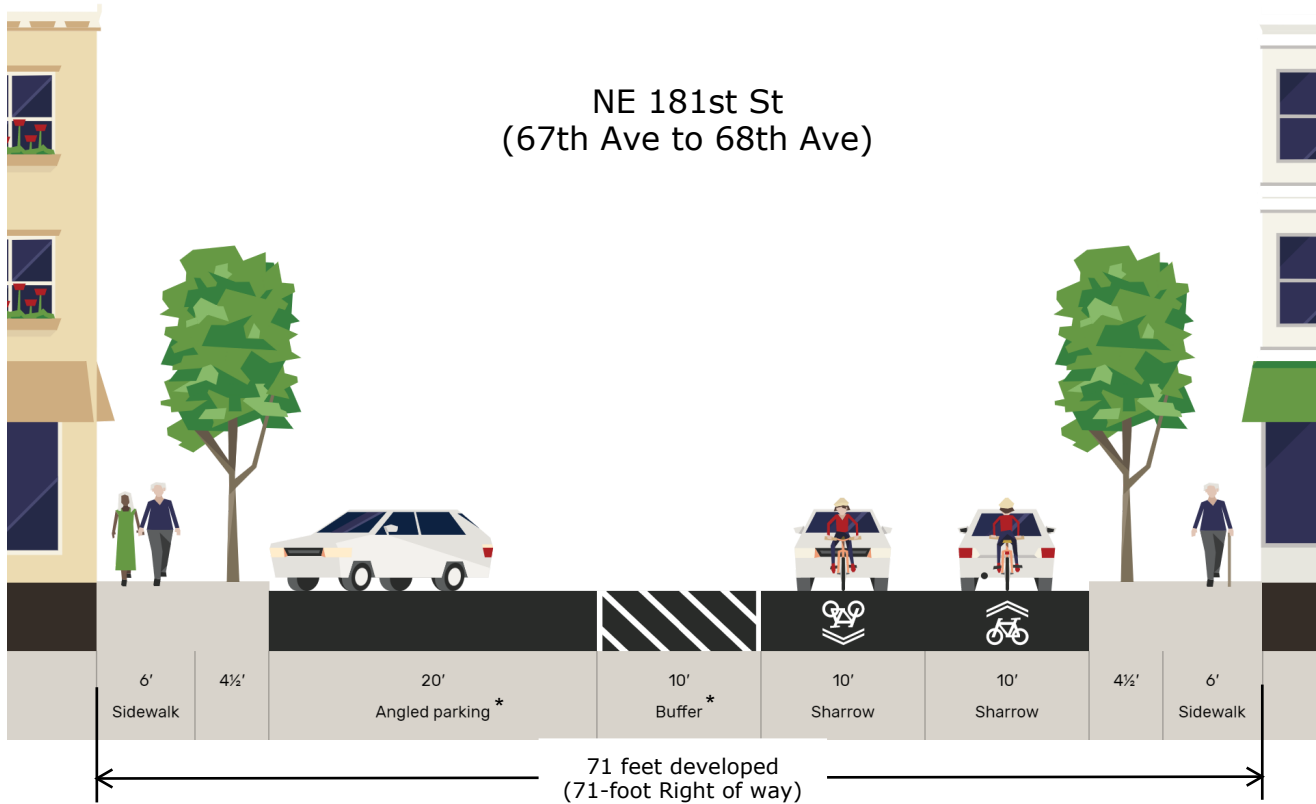

* Angle parking and buffer area right of way reduced to 8-foot wide parallel parking with 2 foot buffer at mid-block to 68th Ave NE.

NE 181st St
(61st Ave to 67th Ave
68th Ave to 73rd Ave)

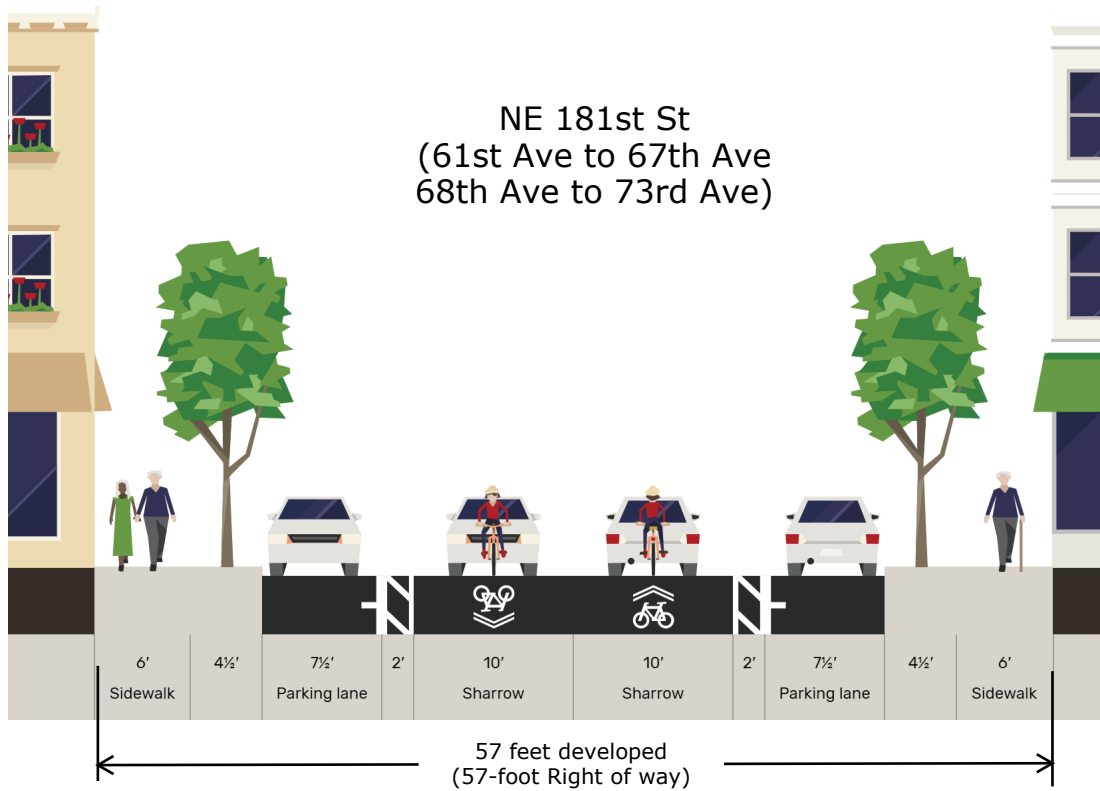

CITY OF KENMORE

ENGINEERING DEPARTMENT
(425) 398-8900

**NE 181st St
Cross Section**

**FIGURE B-9
NOT TO SCALE**

Date: 05/16/2022

84th Ave NE
(145th St to Simonds Rd.)

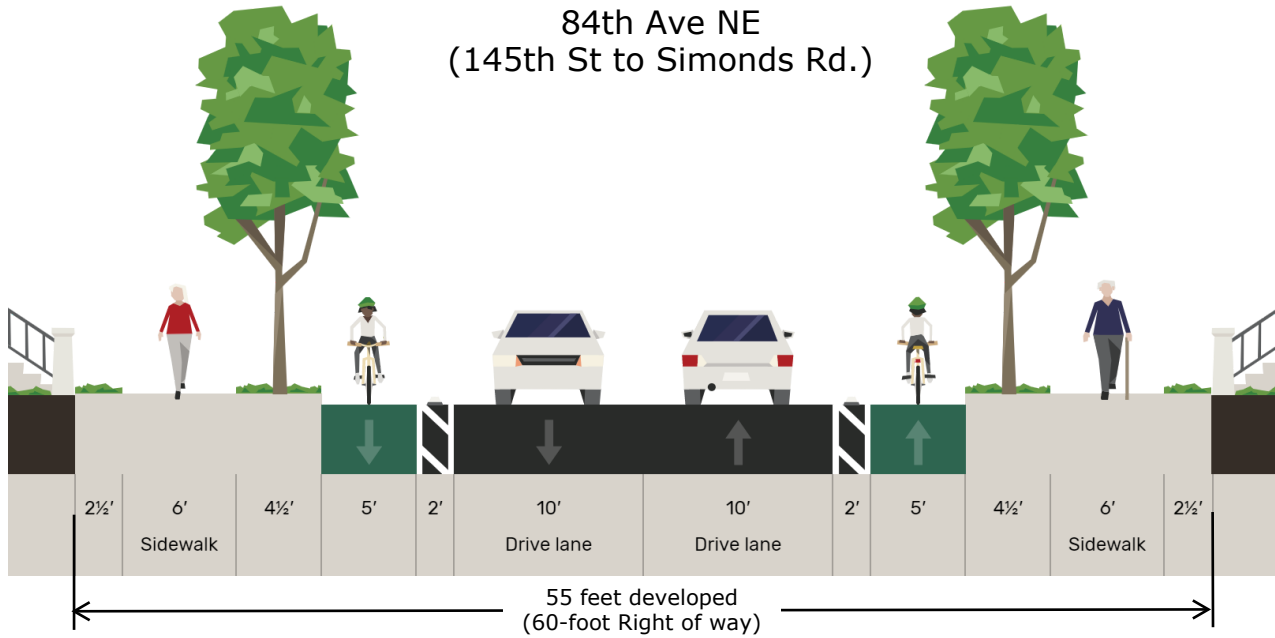

CITY OF KENMORE

ENGINEERING DEPARTMENT
(425) 398-8900

**84th Ave NE
Cross Section**

**FIGURE B-10
NOT TO SCALE**

Date: 05/15/2023

NE 193rd St
(61st Ave to 55th Ave)

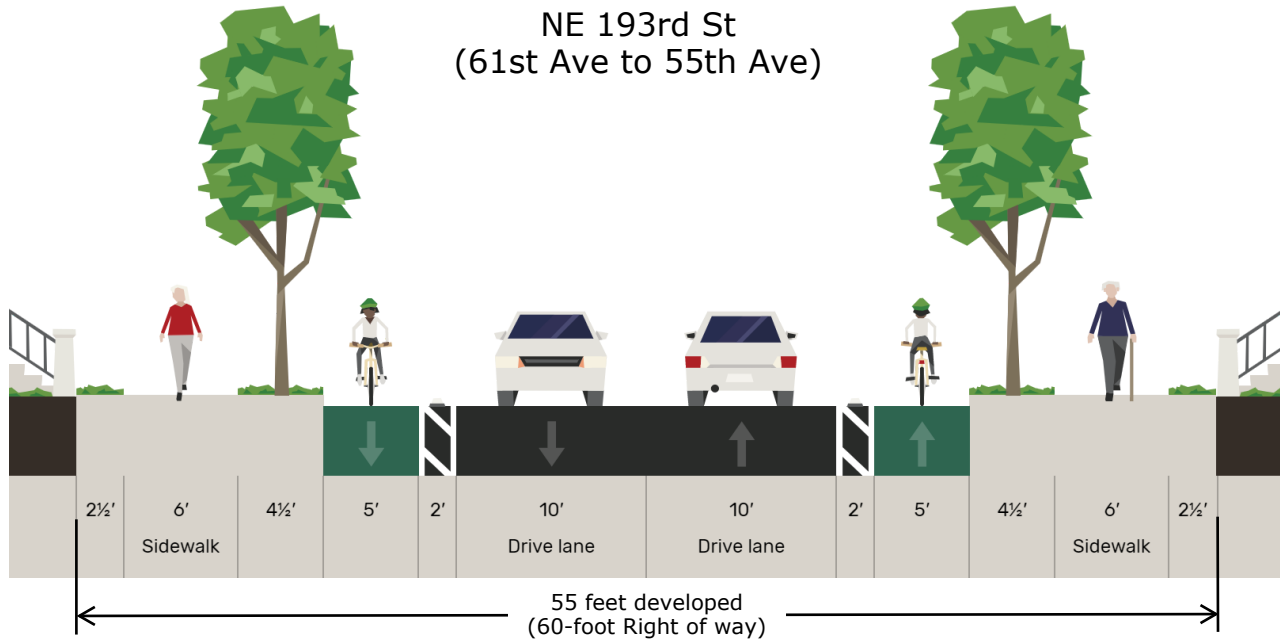

CITY OF KENMORE

ENGINEERING DEPARTMENT
(425) 398-8900

NE 193rd St
Cross Section

FIGURE B-11
NOT TO SCALE

Date: 05/15/2023

NE 203rd St
(80th Ave to East City Limit)

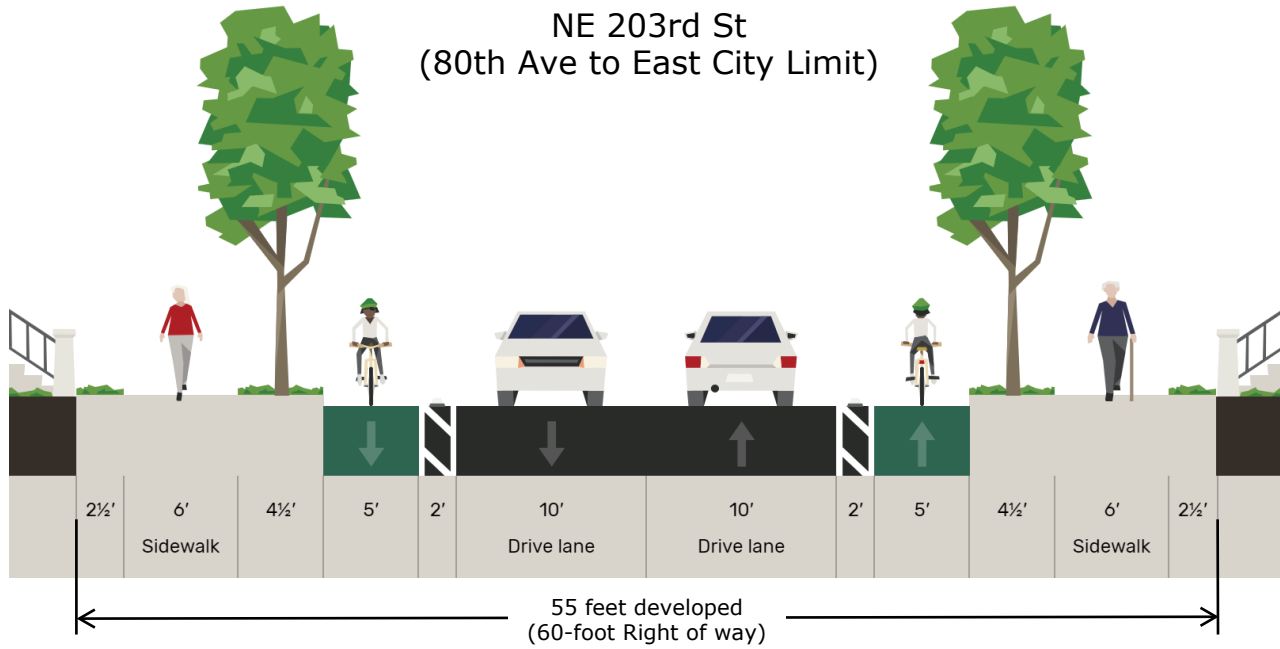

CITY OF KENMORE

ENGINEERING DEPARTMENT
(425) 398-8900

**NE 203rd St
Cross Section**

**FIGURE B-12
NOT TO SCALE**

Date: 05/15/2023

NE 175th St
(61st Ave to 65th Ave)

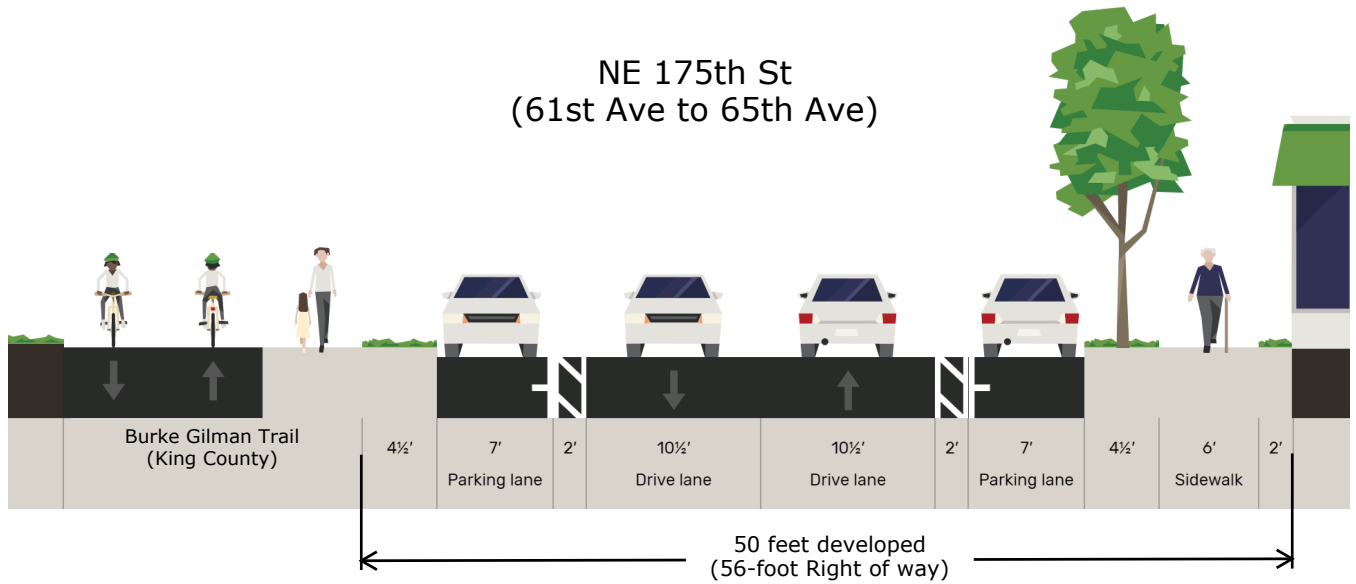

NE 175th St
(65th Ave to 68th Ave)
(~860ft East of 68th to 73rd Ave)

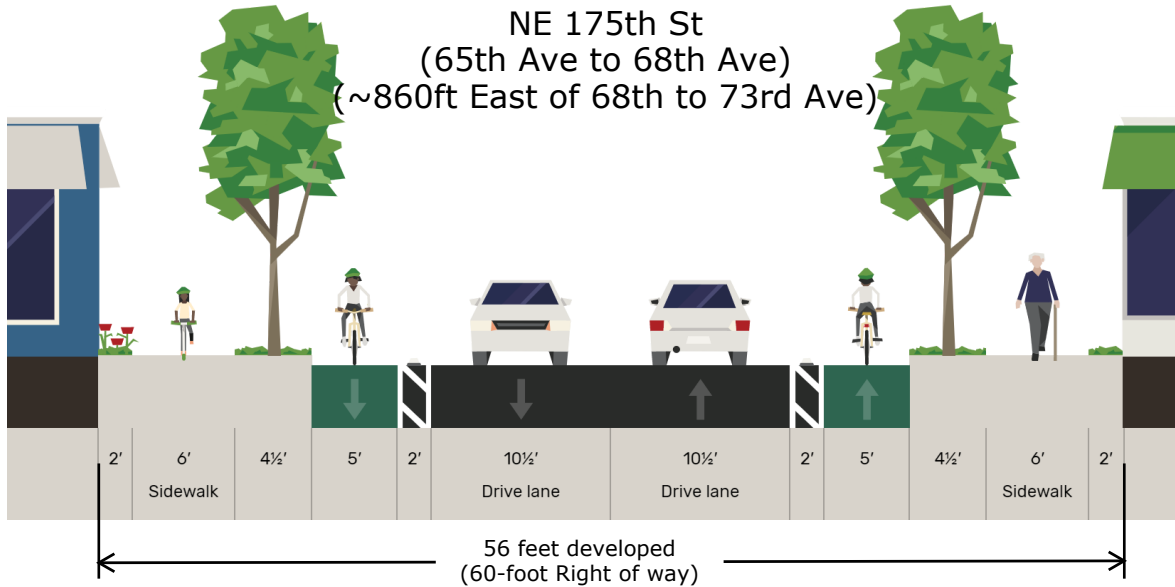

NE 175th St
(68th Ave to ~860ft east of 68th Ave NE)

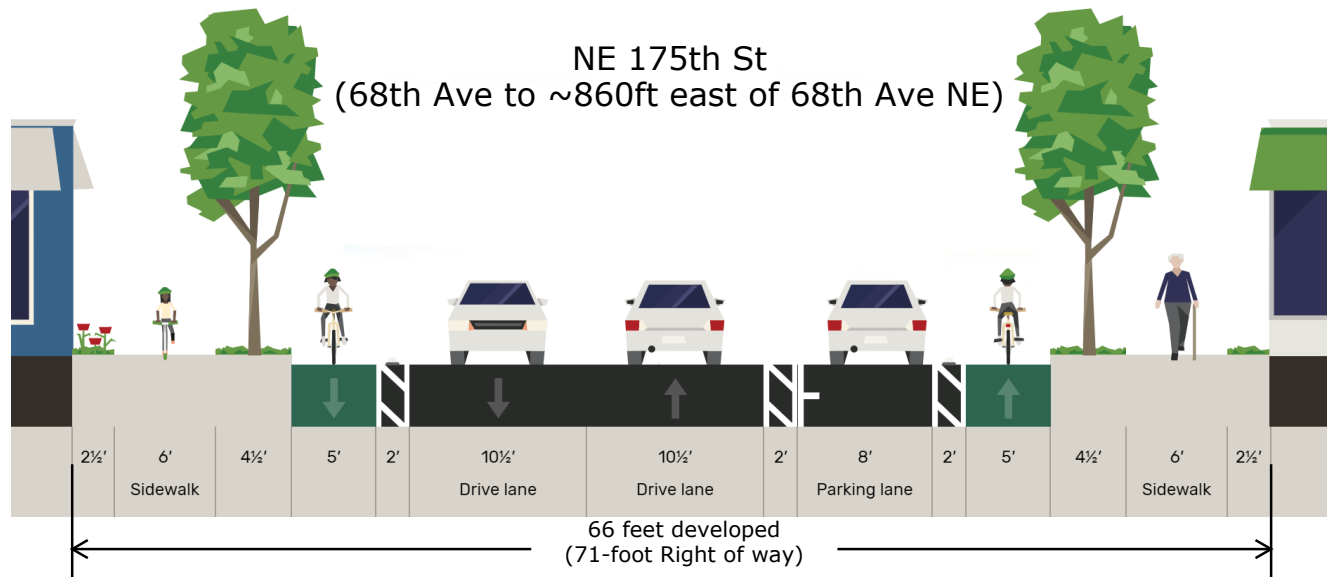

CITY OF KENMORE

ENGINEERING DEPARTMENT
(425) 398-8900

**NE 175th St
Cross Section**

**FIGURE B-13
NOT TO SCALE**

Date: 05/15/2023



APPENDIX C

STREET TREE LIST

CITY OF KENMORE STREET TREE LIST 5/1/2021

The following street tree list includes the main tree species approved for installation within the City's right-of-way. The list incorporates trees that offer maximum flexibility but also ensures the safe and efficient operation of the public right-of-way. Tree selection should be made taking into consideration of the environmental and built condition of any location so that the best suited tree is used. Factors such as, but not limited to, soil type, available space, sun exposure, existing utilities, microclimate, drainage, etc. should be taken into consideration when selecting a tree. The specific site selected should be examined to determine the area needed for future growth for the life of the tree.

Botanical	Common (* denotes drought tolerant)	Mature Height	Mature Width	Deciduous / Evergreen	Size ¹	Approved for Amenity Strip
Abies koreana	Korean Fir	18'	8'	Evergreen	Small	No
Abies pinsapo	Spanish Fir*	30'	15'	Evergreen	Small	No
Abies pinsapo 'Glaucua'	Blue Spanish Fir*	30'	15'	Evergreen	Small	No
Acer buergerianum	Trident Maple*	35'	35'	Deciduous	Medium	Yes
Acer circinatum	Vine Maple*	20'	20'	Deciduous	Small	No
Acer griseum	Paperbark Maple*	30'	25'	Deciduous	Small	Yes
Acer rubrum 'Armstrong'	Armstrong Maple	50'	25'	Deciduous	Large	Yes
Acer rubrum 'Bowhall'	Bowhall	40'	15'	Deciduous	Medium	Yes
Acer saccharum 'Barrett Cole' APOLLO®	Sugar Maple	30'	12'	Deciduous	Small	Yes
Acer saccharum 'Temple's Upright'	Sugar Maple	45'	17'	Deciduous	Medium	Yes
Acer triflorum	Threeflower Maple*	30'	25'	Deciduous	Small	Yes
Acer 'Warrenred' PACIFIC SUNSET®	Painted Maple*	30'	25'	Deciduous	Small	Yes
Amelanchier varieties	Serviceberry*	15'	10'	Deciduous	Small	No
Arbutus unedo	Strawberry tree*	20'	20'	Evergreen	Small	No
Calocedrus decurrens	Incense Cedar*	40'	12'	Evergreen	Medium	No
Cercidiphyllum japonicum (compact varieties available)	Katsura Tree	60'	50'	Deciduous	Large	Yes
Chamaecyparis obtusa 'Filicoides Compacta'	Compact Fernspray Hinoki Cypress*	15'	6'	Evergreen	Small	No
Chamaecyparis obtusa 'Gracilis'	Hinoki Cypress*	25'	10'	Evergreen	Small	No
Cornus 'Eddie's White Wonder'	Eddie's White Wonder Dogwood	35'	20'	Deciduous	Medium	Yes
Cornus kousa var. chinensis 'Milky Way'	Chinese Dogwood	30'	25'	Deciduous	Small	Yes
Cornus mas	Cornelian cherry*	15'	15'	Deciduous	Small	Yes
Fagus sylvatica 'Rohan Obelisk'	Columnar Purple Beech	35'	15'	Deciduous	Medium	Yes
Ginkgo biloba 'Tubifolia'	Maidenhair Tree*	25'	18'	Deciduous	Small	Yes
Koelreuteria paniculata	Goldenrain Tree*	30'	25'	Deciduous	Small	Yes
Malus 'Adirondack'	Flowering Crabapple*	18'	10'	Deciduous	Small	Yes

Botanical	Common (* denotes drought tolerant)	Mature Height	Mature Width	Deciduous / Evergreen	Size ¹	Approved for Amenity Strip
Malus 'Jewelcole' RED JEWEL™	Flowering Crabapple*	15'	12'	Deciduous	Small	Yes
Malus 'Sutyzam' SUGAR TYME™	Flowering Crabapple*	18'	15'	Deciduous	Small	Yes
Malus transitoria 'Schmidtcutleaf' GOLDEN RAINDROPS™	Flowering Crabapple*	20'	15'	Deciduous	Small	Yes
Liriodendron tulipifera 'Fastigiatum'	Columnar Tulip Tree*	60'	20'	Deciduous	Large	Yes
Parrotia persica	Persian Ironwood*	40'	40'	Deciduous	Large	Yes
Parrotia persica 'Vanessa'	Persian Ironwood*	40'	20'	Deciduous	Medium	Yes
Picea omorika	Serbian Spruce*	30'	10'	Evergreen	Small	No
Pinus contorta 'Chief Joseph'	Golden Lodgepole Pine	20'	6'	Evergreen	Small	No
Pinus flexilis 'Vanderwolf's Pyramid'	Limber Pine*	25'	15'	Evergreen	Small	No
Pinus thunbergii 'Thunderhead'	Compact Japanese Black Pine*	20'	20'	Evergreen	Small	No
Quercus palustris 'Pringreen' GREEN PILLAR™	Columnar Pin Oak	45'	15'	Deciduous	Medium	Yes
Quercus rubra	Red Oak	50'	40'	Deciduous	Large	Yes
Tsuga mertensiana	Mountain Hemlock	20'	8'	Evergreen	Small	No

1. Small trees required a minimum amenity strip/planting area width of 4 feet wide
Medium trees require a minimum amenity strip/planting area width of 5 feet wide
Large trees require a minimum amenity strip/planting area width of 6 feet wide



APPENDIX D

STANDARD PLAN NOTES

CITY OF KENMORE STANDARD PLAN NOTES

(Last Updated 5/18/2023)

The standard plan notes must be included on all engineering plans. Notes which in no way apply to the project may be omitted and replaced with the term "not used"; the remaining notes must not be renumbered.

GENERAL NOTES

- (1) All design and construction shall be in accordance with permit conditions, the Kenmore Municipal Code (KMC), City of Kenmore 2021 Road Standards (KRS), 2021 King County Surface Water Design Manual (as amended by City of Kenmore), Washington State Department of Transportation (WSDOT) Standard Specifications (current edition), and the conditions of preliminary approval. It shall be the sole responsibility of the applicant and the professional civil engineer of record to correct any error, omission, or variation from the above requirements found in these plans. All corrections shall be at no additional cost or liability to the City of Kenmore.
- (2) The design elements within these plans have been reviewed against the existing codes and standards at the time of application. Some elements may have been overlooked or missed by the City of Kenmore plan reviewer. Any variance from adopted standards is not allowed unless specifically approved by the City of Kenmore prior to construction.
- (3) Approval of these plan does not constitute an approval of any other construction (e.g. domestic water conveyance, sewer conveyance, gas, electrical, etc.) not included in this plan set or if included, not specifically approved either in writing to the City or on the plans themselves by the approving agency.
- (4) Before any construction or development activity, a pre-construction meeting must be held between the City's Inspector, the Applicant, and the Applicant's Construction Representative.
- (5) A copy of these approved plans must be on the job site whenever construction is in progress.
- (6) Construction activities are limited to the hours of 7 a.m. to 7 p.m. Monday through Friday and 9 a.m. to 5 p.m. on Saturday. No construction is to take place on Sundays or Holidays.
- (7) It shall be the applicant's / contractor's responsibility to obtain all construction easements necessary before beginning any off-site work. Easements require review and approval by the City prior to construction.
- (8) Utilities or other installations that are not shown on these approved plans shall not be constructed unless an approved set of plans that meet all standard requirements are submitted to the City of Kenmore 30 days prior to construction.
- (9) Datums shall be NAVD 88 and NAD 83/91 (KMC 17.15.130), unless otherwise approved by the City of Kenmore.
- (10) Dewatering system (underdrain) construction shall be within the right-of-way or appropriate drainage easement, but not underneath the roadway section. All underdrain systems must be constructed in accordance with WSDOT Standard Specifications.
- (11) All utility trenches and roadway subgrade shall be backfilled and compacted in accordance with KRS Chapter 9.
- (12) All pavement shall be compacted in accordance with KRS Chapter 9.
- (13) Open cutting of existing roadways for utility or storm work is not allowed unless specifically approved by the City of Kenmore and noted on these approved plans. Any open cut shall be restored in accordance with KRS.
- (14) The Contractor shall be responsible for providing adequate safeguards, safety devices, protective equipment, flaggers, and any other needed actions to protect the life, health, and safety of the public, and to protect property in connection with the performance of work covered by the contractor. Any work within the traveled right-of-way that may interrupt normal traffic flow shall require at least one flagger for each lane of traffic affected. The most current Manual on Uniform Traffic Control Devices (MUTCD) shall apply. Work in right-of-way is not authorized until a traffic control plan is approved by the City of Kenmore.

DRAINAGE NOTES

- (1) Proof of liability insurance shall be submitted to the City of Kenmore prior to the construction of the drainage facilities, preferably at the pre-construction meeting.
- (2) All pipe and appurtenances shall be laid on a properly prepared foundation in accordance with WSDOT specifications. This shall include leveling and compacting the trench bottom, the top of the foundation material, and any required pipe bedding, to a uniform grade so that the entire pipe is supported by a uniformly dense unyielding base.
- (3) Steel pipe shall be aluminized or galvanized with asphalt treatment #1 or better inside and outside.
- (4) All drainage structures, such as catch basins and manholes, not located within drainage flow line, shall have solid locking lids. All drainage structures associated with a permanent retention/detention facility shall have solid locking lids.
- (5) All catch basin grates shall conform to KRS.
- (6) All driveway culverts located within City of Kenmore right-of-way shall be of sufficient length to provide a minimum 4:1 slope from the edge of the driveway to the bottom of the ditch. Culverts shall have beveled end sections to match the side slope requirement of KRS.
- (7) Rock for erosion protection of roadway ditches, where required, must be of sound quarry rock, placed to a depth of 1 foot, and must meet the following specifications: 4"-8"/40%-70% passing; 2"- 4" rock/30%-40% passing; and -2" rock/10%-20% passing. Installation shall be in accordance with KRS.
- (8) Drainage outlets (stub-outs) shall be provided for each individual lot, except for those lots approved for infiltration or other BMP by the City of Kenmore. Stub-outs shall conform to the following:
 - a) Each outlet shall be suitably located at the lowest elevation on the lot, so as to service all future roof downspouts and footing drains, driveways, yard drains, and any other surface or subsurface drains necessary to render the lots suitable for their intended use. Each outlet shall have free-flowing, positive drainage to an approved stormwater conveyance system or to an approved outfall location.
 - b) Outlets on each lot shall be located with a five-foot-high, 2" x 4" stake marked "storm" or "drain". The stub-out shall extend above surface level, be visible, and be secured to the stake.
 - c) Pipe material shall conform to underdrain specifications described in KRS and, if non-metallic, the pipe shall contain wire or other acceptable detection.
 - d) Drainage easements are required for drainage systems designed to convey flows through individual lots.
 - e) The applicant/contractor is responsible for coordinating the locations of all stub-out conveyance lines with respect to the utilities (e.g. power, gas, telephone, television).
 - f) All individual stub-outs shall be privately owned and maintained by the lot homeowner.
- (9) All disturbed pervious areas (compacted, graded, landscaped, etc.) of the development site must demonstrate one of the following: The existing duff layer shall be staged and redistributed to maintain the moisture capacity of the soil, OR; Amended soil shall be added to maintain the moisture capacity.
- (10) Seasonal clearing is limited between October 1 and April 30 inclusive, unless otherwise approved with a written decision by the City of Kenmore.
- (11) All new storm sewer pipe including connected existing storm sewer pipe shall have a video inspection performed from structure to structure, unless otherwise approved by the City Engineer. Video shall capture sidewalls and shall provide a close view of all joints.
- (12) All new storm sewer pipe shall be jet cleaned and all catch basins cleaned of all soil, rock and any other foreign material. All existing pipe and catch basins within the project limits shall be jet cleaned. All material shall be collected and disposed of off-site.

EROSION AND SEDIMENTATION CONTROL NOTES

- (1) Approval of the project's erosion and sedimentation control (ESC) plan does not constitute an approval of permanent road or drainage design (e.g. size and location of roads, pipes, restrictors, channels, retention facilities, utilities, etc.)
- (2) The implementation of these ESC plans and the construction, maintenance, replacement, and upgrading of these ESC facilities is the responsibility of the applicant/ESC supervisor until all construction is approved.
- (3) The boundaries of the clearing limits shown on this plan shall be clearly flagged by survey tape or fencing, if required, prior to construction (KCSWDM Appendix D). During the construction period, no disturbance beyond the clearing limits shall be permitted. The clearing limits shall be maintained per the standards by the applicant/ESC supervisor for the duration of construction.
- (4) Stabilized construction entrances shall be installed at the beginning of construction and maintained for the duration of the project. Additional measures, such as constructed wheel wash systems or wash pads, may be required to ensure that all paved areas are kept clean and track out to road right of way does not occur for the duration of the project.
- (5) The ESC facilities shown on this plan must be constructed prior to or in conjunction with all clearing and grading so as to ensure that the transport of sediment to surface waters, drainage systems, and adjacent properties is minimized.
- (6) The ESC facilities shown on this plan are the minimum requirements for anticipated site conditions. During the construction period, these ESC facilities shall be upgraded as needed for unexpected storm events and modified to account for changing site conditions (e.g. additional cover measures, additional sump pumps, relocation of ditches and silt fences, perimeter protection etc.).
- (7) The ESC facilities shall be inspected daily by the applicant/ESC supervisor and maintained to ensure continued proper functioning. Written records shall be kept of weekly reviews of the ESC facilities.
- (8) Any areas of exposed soils, including roadway embankments that will not be disturbed for two days during the wet season or seven days during the dry season shall be immediately stabilized with the approved ESC cover methods (e.g., seeding, mulching, plastic covering, etc.).
- (9) Any area needing ESC measures, not requiring immediate attention, shall be addressed within seven (7) days.
- (10) The ESC facilities on inactive sites shall be inspected and maintained a minimum of once a month or within 24 hours following a storm event.
- (11) At no time shall more than one (1) foot of sediment be allowed to accumulate within a catch basin. All catch basins and conveyance lines shall be cleaned prior to paving. The cleaning operation shall not flush sediment-laden water into the downstream system.
- (12) Any permanent retention/detention facility used as a temporary settling basin shall be modified with the necessary erosion control measures and shall provide adequate storage capacity. If the permanent facility is to function ultimately as an infiltration system, the temporary facility must be rough graded so that the bottom and sides are at least three feet above the final grade of the permanent facility.
- (13) Cover measures will be applied in conformance with Appendix D of the Surface Water Design Manual.
- (14) Prior to the beginning of the wet season (October 1), all disturbed areas shall be reviewed to identify which ones can be seeded in preparation for the winter rains. Disturbed areas shall be seeded within one week of the beginning of the wet season. A sketch map of those areas to be seeded and those areas to remain uncovered shall be submitted to the City inspector for review. See KCSWDM D.2.4.2 and D.2.4.3 for additional requirements.

STRUCTURAL NOTES

- (1) Rockeries are considered to be a method of bank stabilization and erosion control. Rockeries shall not be constructed to serve as retaining walls. Rockeries shall be constructed in accordance with the International Building Code.

EROSION AND SEDIMENT CONTROL RECOMMENDED CONSTRUCTION SEQUENCE

- (1) Pre-construction meeting.
- (2) Post sign with name and phone number of ESC supervisor (may be consolidated with the required notice of construction sign).
- (3) Flag or fence clearing limits.
- (4) Install catch basin protection if required.
- (5) Grade and install construction entrance(s).
- (6) Install perimeter protection (silt fence, brush barrier, etc.).
- (7) Construct sediment ponds and traps.
- (8) Grade and stabilize construction roads.
- (9) Construct surface water controls (interceptor dikes, pipe slope drains, etc.) simultaneously with clearing and grading for project development.
- (10) Maintain erosion control measures in accordance with KRS and manufacturer's recommendations.
- (11) Relocate erosion control measures or install new measures so that as site conditions change, the erosion and sediment control is always in accordance with the City's Erosion and Sediment Control Standards.
- (12) Cover all areas that will be unworked for more than seven days during the dry season or two days during the wet season with straw, wood fiber mulch, compost, plastic sheeting or equivalent.
- (13) Stabilize all areas that reach final grade within seven days.
- (14) Seed or sod any areas to remain unworked for more than 30 days.
- (15) Upon completion of the project, all disturbed areas must be stabilized and BMPs removed if appropriate.



APPENDIX E

STANDARD DETAILS

CITY OF KENMORE STANDARD DETAILS 5/20/2023

These standard details are meant to provide a standard of construction within the City of Kenmore. These details are not meant to contain all necessary information needed for construction. The engineer of record is responsible for reviewing these standard details for applicability and conformance to the proposed design and for providing all additional information or modifications as required to construct the proposed improvements. Any standard detail not addressing a particular design need, the Engineer of Record shall either use applicable standard details from King County or the Washington State Department of Transportation or create their own project specific details.

TABLE OF CONTENTS:

Standard Plan Series	Description	Standard Number	Standard title
2	Roadway Features	2-001	Traffic Circle
		2-002	Hammerhead Turnaround
		2-003	Cul-de-sac Turnaround
		2-004	Speed Table
		2-005	Speed Hump
3	Structures	3-001	Rock Wall - Cut Section
		3-002	Rock Wall - Fill Section
		3-003	Block Wall - Cut Section
		3-004	Block Wall - Fill Section
4	Channelization/Striping	4-001	Crosswalk and stop bar
		4-002	Pavement Marking Detail
		4-003	Not Used
		4-004	Bicycle Lanes
5	Paving	5-001	Roadway Cross Section
		5-002	Trench cut
6	Roadside Features	6-001	Mailbox wood post
		6-002	Traffic sign
		6-003	Wood Post Foundation
		6-004	Mailbox Collection Unit
		6-005	Mailbox Cluster
		6-006	Pedestrian Railing
		6-007	Planting
		6-008	Tree Grate Detail
		6-009	Hank Heron

Standard Plan Series	Description	Standard Number	Standard title
7	Storm Drainage	7-001	Beveled End Pipe Section
		7-002	Trench Cut Storm Drainage
		7-003	Catch Basin Type 1
		7-004	Catch Basin Type 1L
		7-005	Catch Basin Type 2
		7-006	Catch Basin Type 2 Details
		7-007	Vaned Grate
		7-008	Diagonal Slotted Grate
		7-009	Solid Cover
		7-010	Square Frame
		7-011	Debris Cage for Catch Basin
8	Sidewalk/Driveways	8-001	Sidewalks
		8-002	Perpendicular Curb Ramp
		8-003	Parallel Curb Ramp
		8-004	Combination Ramp
		8-005	Transition Ramp to Shoulder
		8-006	Driveway Type 1 (with amenity zone)
		8-007	Driveway Type 2 (without amenity zone)
		8-008	Concrete Finishing
		8-009	Curbs
		8-010	Integral Curb Sidewalk
		8-011	Thickened Edge Sidewalk
		8-012	Pedestrian Curb

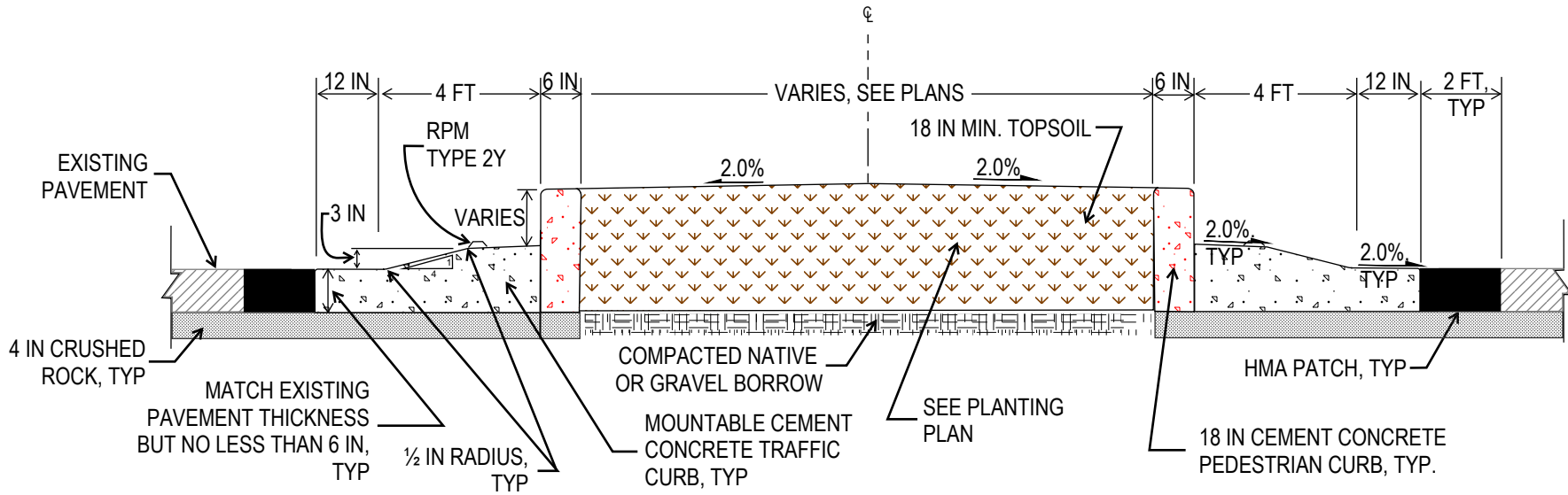

SECTION A-A'



30X30 W41-124, SEE NOTE 4 30X30 W2-6, SEE NOTE 3

NOTES:

1. ADJUST MONUMENTS AND UTILITY LIDS/RIMS TO GRADE
2. PLANT MATERIAL AND LAYOUT TO BE APPROVED BY CITY BEFORE PLANTING
3. ADVANCE WARNING SIGNS ON EACH ROAD APPROACHING TRAFFIC CIRCLE - LOCATE PER PLAN OR AS DIRECTED BY CITY
4. MOUNT ONE SIGN FACING EACH DIRECTION OF TRAVEL ON WOOD POST PER KSD 6-002, CENTER POST ON TRAFFIC CIRCLE

5, FULL DEPTH EXPANSION JOINTS, EQUALLY SPACED

REFLECTIVE PAVEMENT MARKERS (RPM)
TYPE 2 YELLOW, EQUALLY SPACED:
USE 10 FOR < 15' DIAMETER
USE 15 FOR ≥ 15' DIAMETER

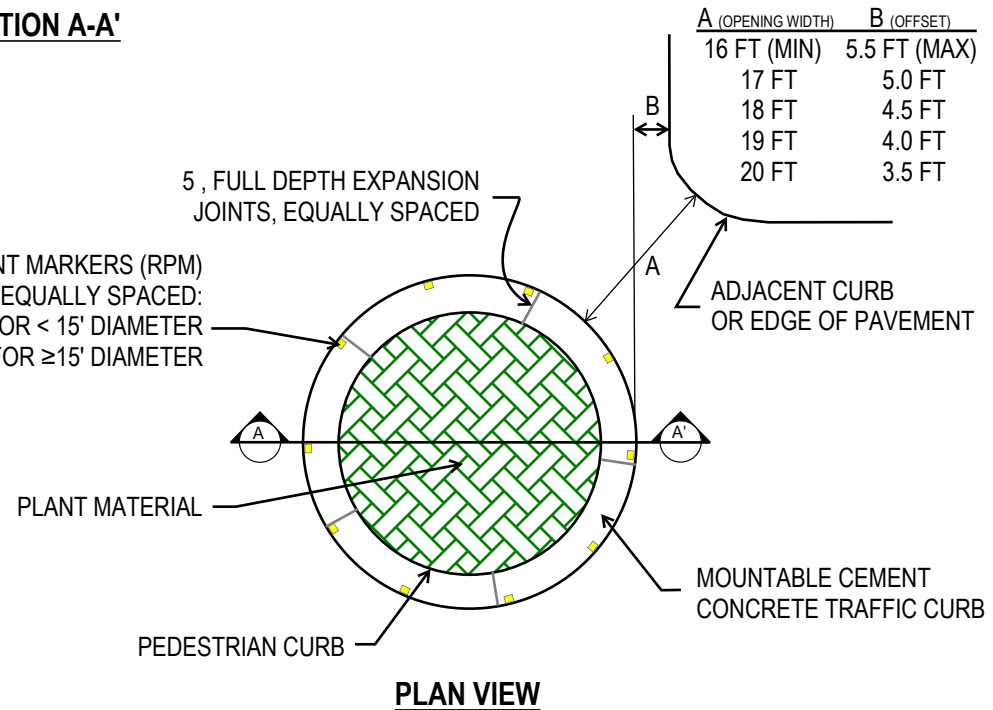

PLAN VIEW



CITY OF KENMORE

ENGINEERING DEPARTMENT
(425) 398-8900



TRAFFIC CIRCLE

FIGURE 2-001

NOT TO SCALE

Date: 05/16/2023

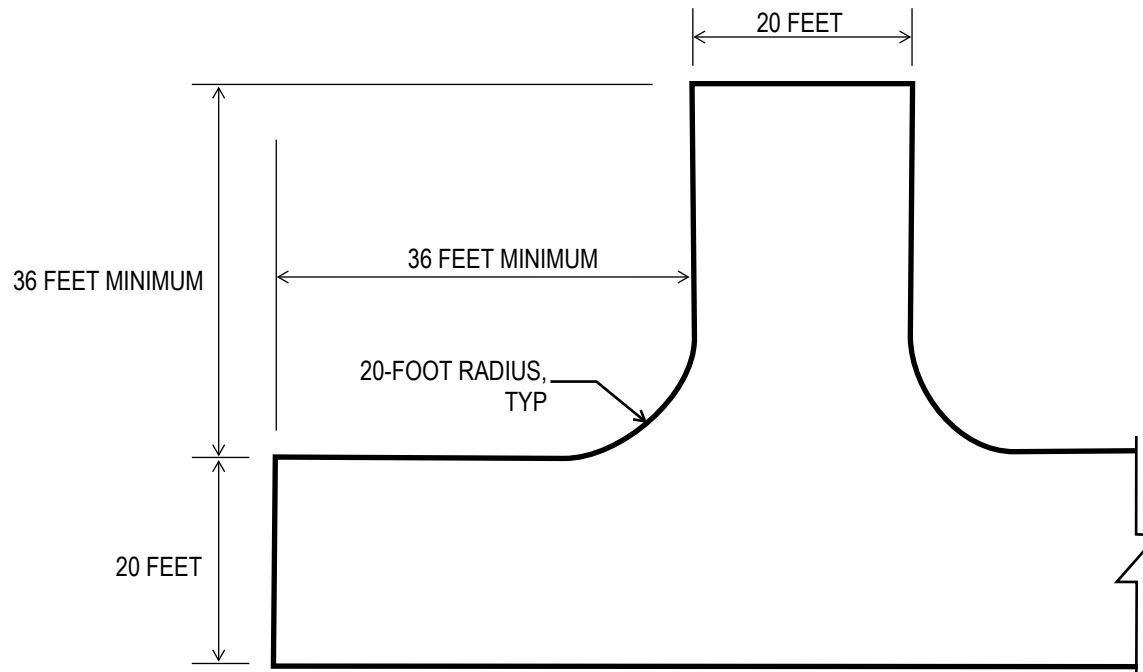

NOTES

1. ALL STREET ENDS SHALL BE SIGNED PER THE MOST CURRENT MUTCD
2. HAMMERHEAD ROADWAY WIDTH IS THE PAVEMENT SECTION ONLY AND DOES NOT INCLUDE ANY REQUIRED SIDEWALK OR UTILITY EASEMENT
3. NO PARKING IS ALLOWED WITHIN THE HAMMERHEAD AREA SHOWN



CITY OF KENMORE

ENGINEERING DEPARTMENT
(425) 398-8900



Hammerhead Turnaround

FIGURE 2-002

NOT TO SCALE

Date: 11/13/2020

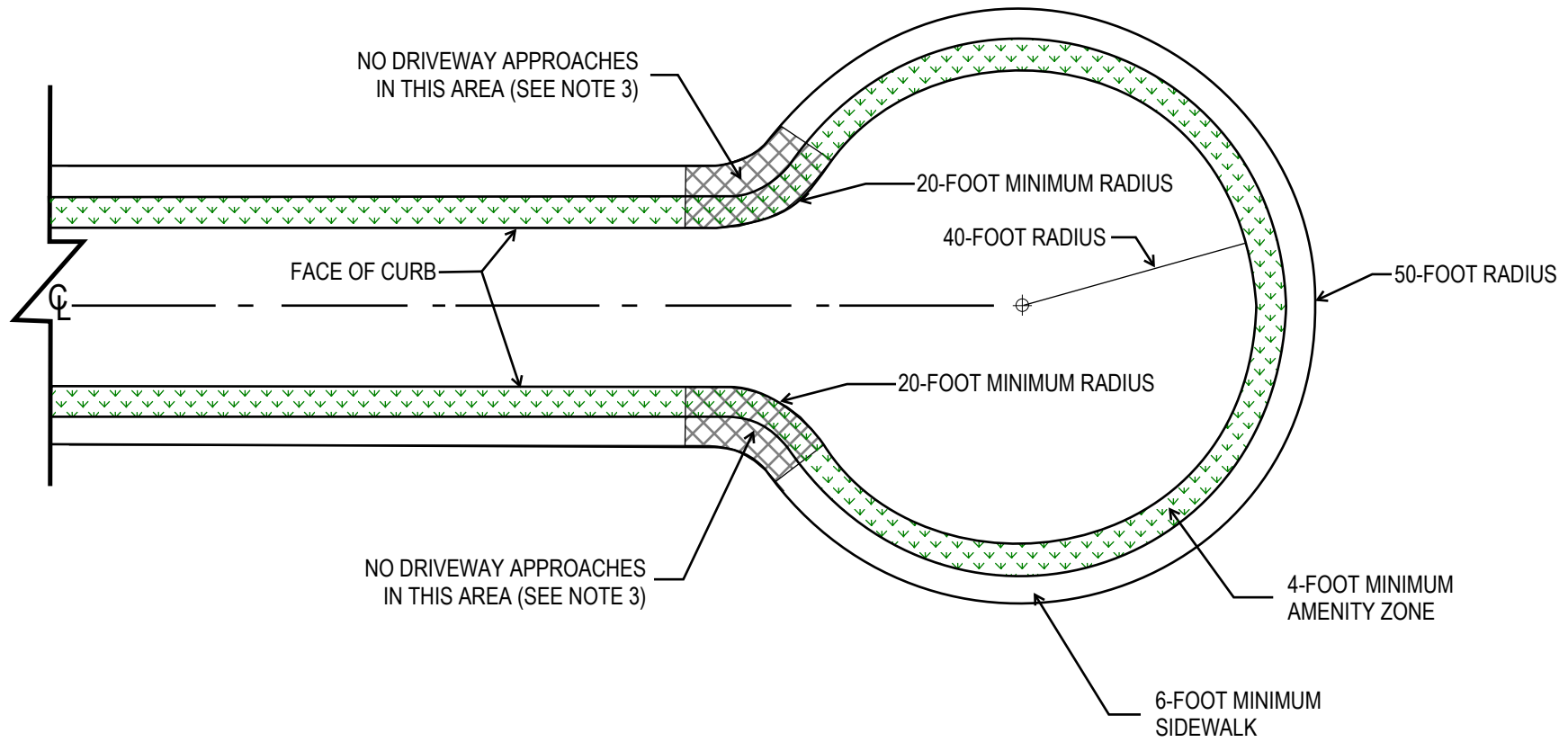

NOTES

1. ROADWAY APPROACH WIDTH VARIES, SEE KENMORE ROAD STANDARDS TABLE 6.1
2. STREET SIGNAGE WILL BE DETERMINED BY THE CITY ENGINEER.
3. DRIVEWAY APPROACHES MAY NOT BE LOCATED WITHIN 5 FEET OF THE RADIUS.



CITY OF KENMORE

ENGINEERING DEPARTMENT
(425) 398-8900



CUL-de-SAC

FIGURE 2-003

NOT TO SCALE

Date: 11/13/2020

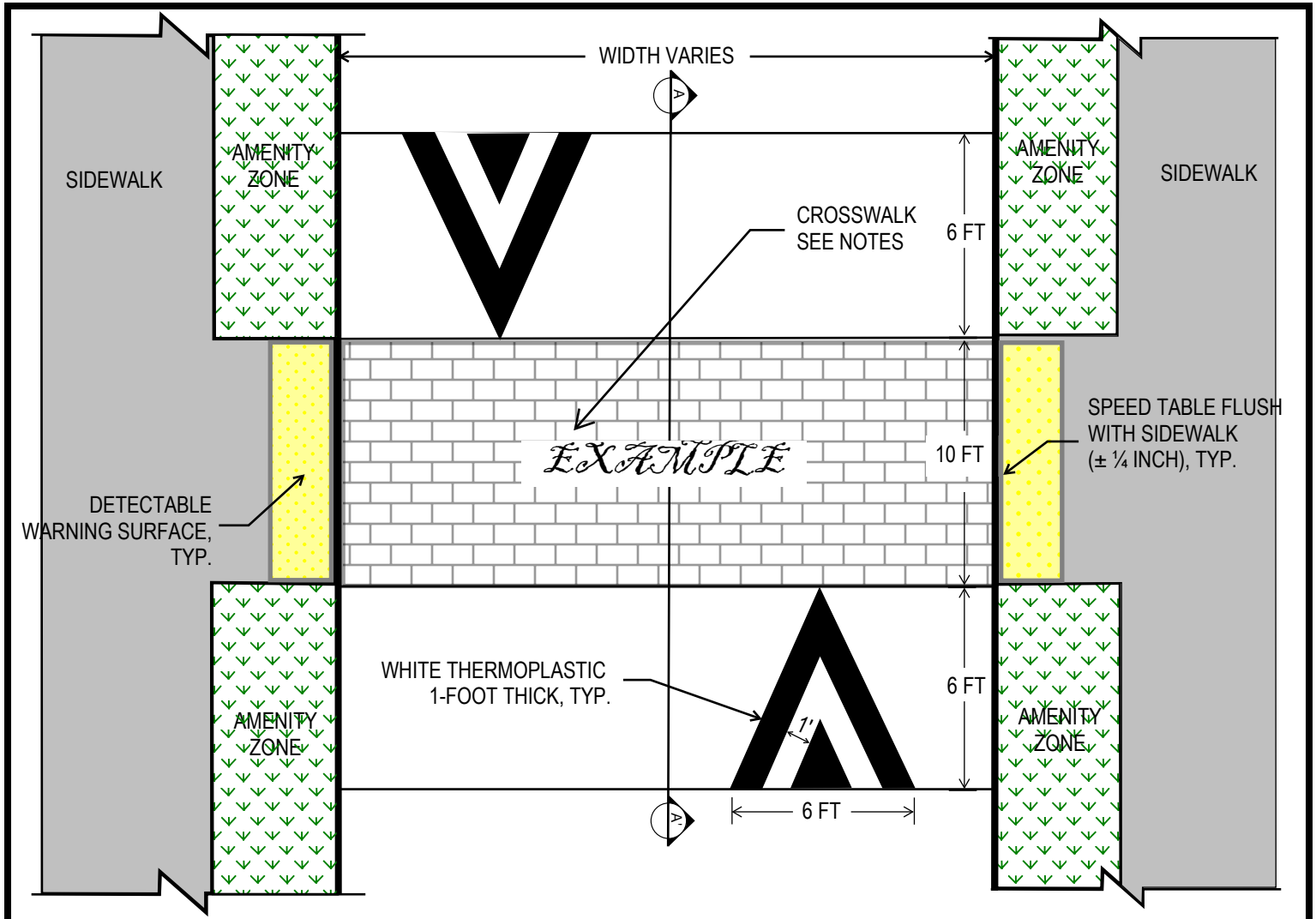

PLAN VIEW

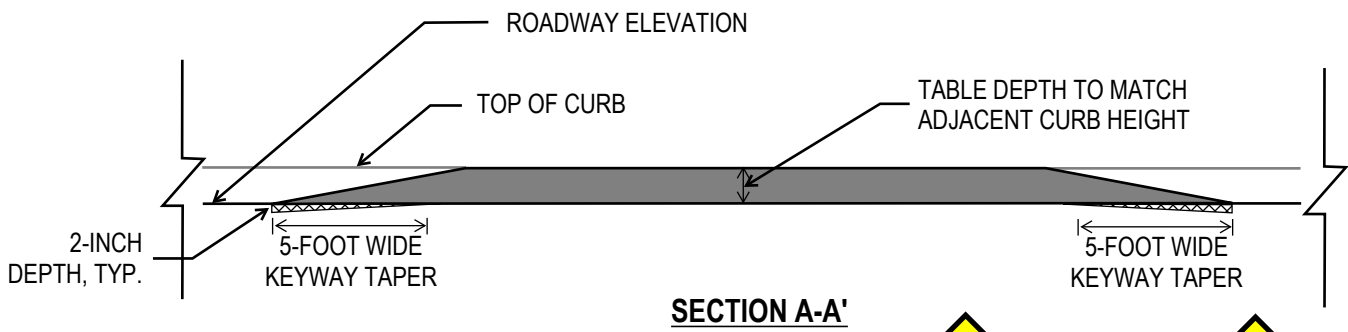

- NOTES:
1. CROSSWALK SHALL BE A CONTRASTING COLOR OR PATTERN AS APPROVED BY THE CITY
 2. SIGNS SHALL BE INSTALLED ON BOTH APPROACHES TO THE SPEED TABLE, "SPEED TABLE 15 MPH" SHALL BE PLACED APPROXIMATELY 25 FEET FROM SPEED TABLE. "SPEED TABLE AHEAD" SHALL BE PLACED APPROXIMATELY 150 FEET FROM "SPEED TABLE 15 MPH" SIGN.
 3. ADDITIONAL STORM DRAINAGE MAY BE REQUIRED TO ADDRESS PONDING.

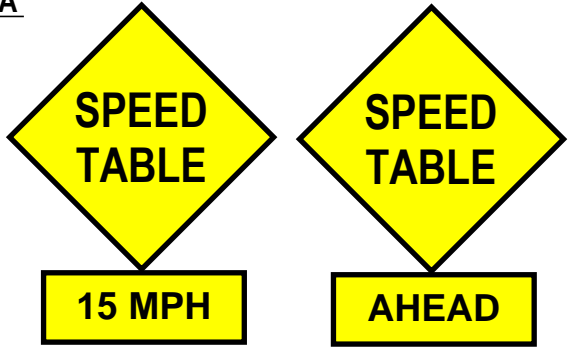

WHITE THERMOPLASTIC, TYP.

FACE OF CURB/EDGE OF PAVEMENT

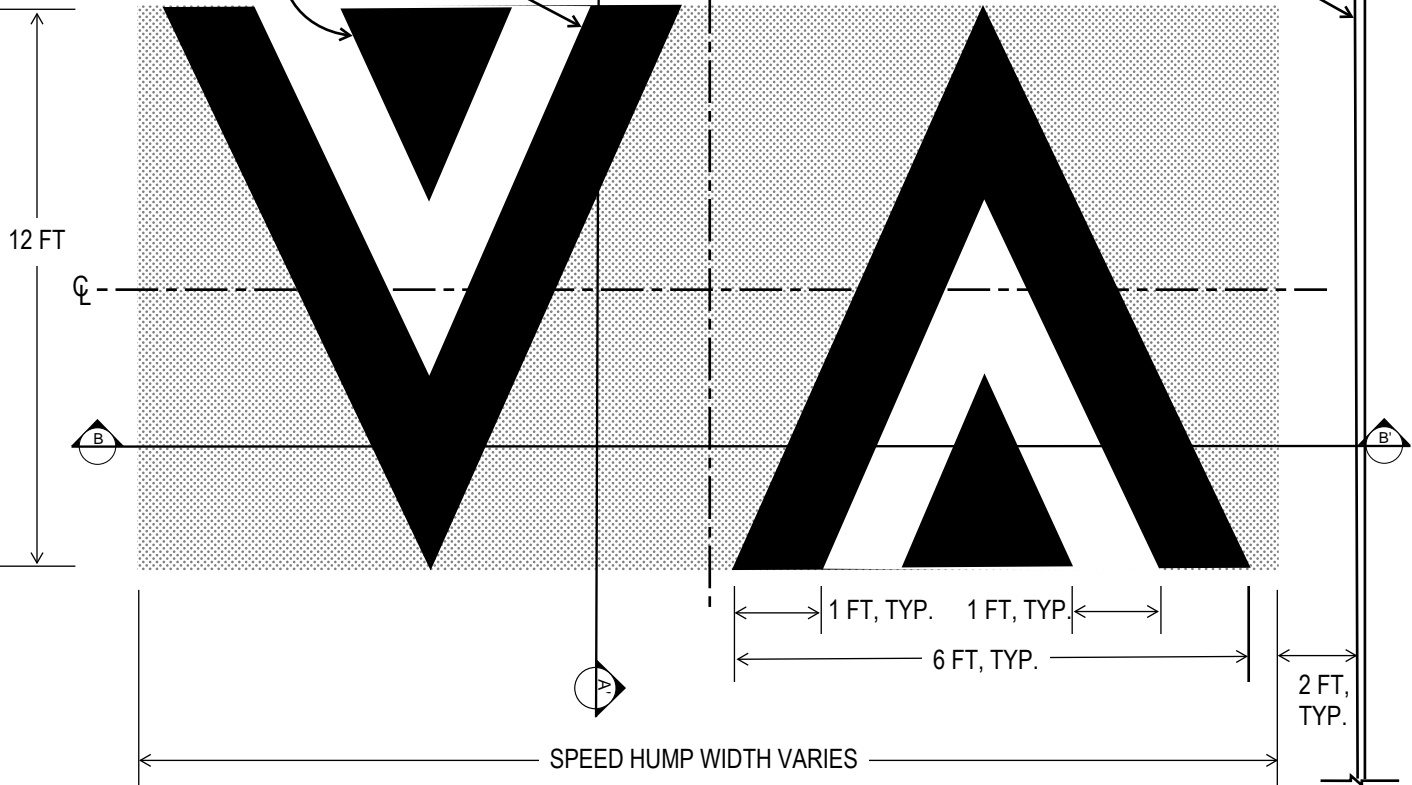

SPEED HUMP PLAN VIEW

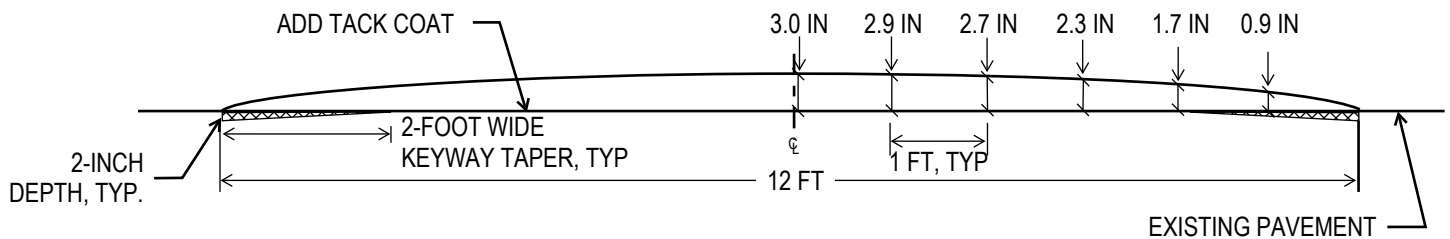

SECTION A-A'

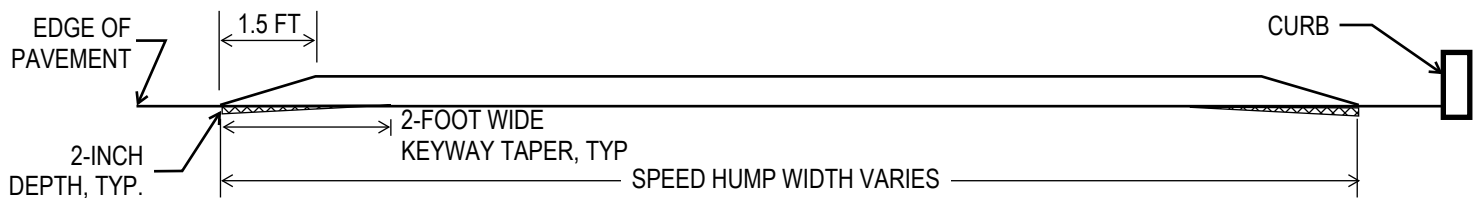

SECTION B-B'

NOTES:

1. SIGNS SHALL BE INSTALLED ON BOTH APPROACHES TO THE SPEED HUMP, "SPEED HUMP 15 MPH" SHALL BE PLACED APPROXIMATELY 25 FEET FROM SPEED HUMP. "SPEED HUMP AHEAD" SHALL BE PLACED APPROXIMATELY 150 FEET FROM "SPEED HUMP 15 MPH" SIGN
2. SPEED HUMP DESIGN SHALL BE COORDINATED WITH EMERGENCY SERVICES (FIRE AND AID CAR). A SPLIT SPEED HUMP IS ALLOWED IF REQUESTED BY EMERGENCY SERVICES
3. CENTER STRIPING ON EACH HALF OF HUMP
4. A MINIMAL GAP AT THE CENTER MAY BE INCLUDED AT THE REQUEST OF EMERGENCY SERVICES

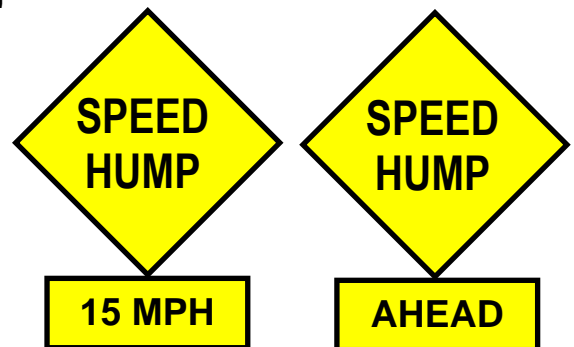

CITY OF KENMORE

ENGINEERING DEPARTMENT
(425) 398-8900



SPEED HUMP

FIGURE 2-005

NOT TO SCALE

Date: 11/18/2020

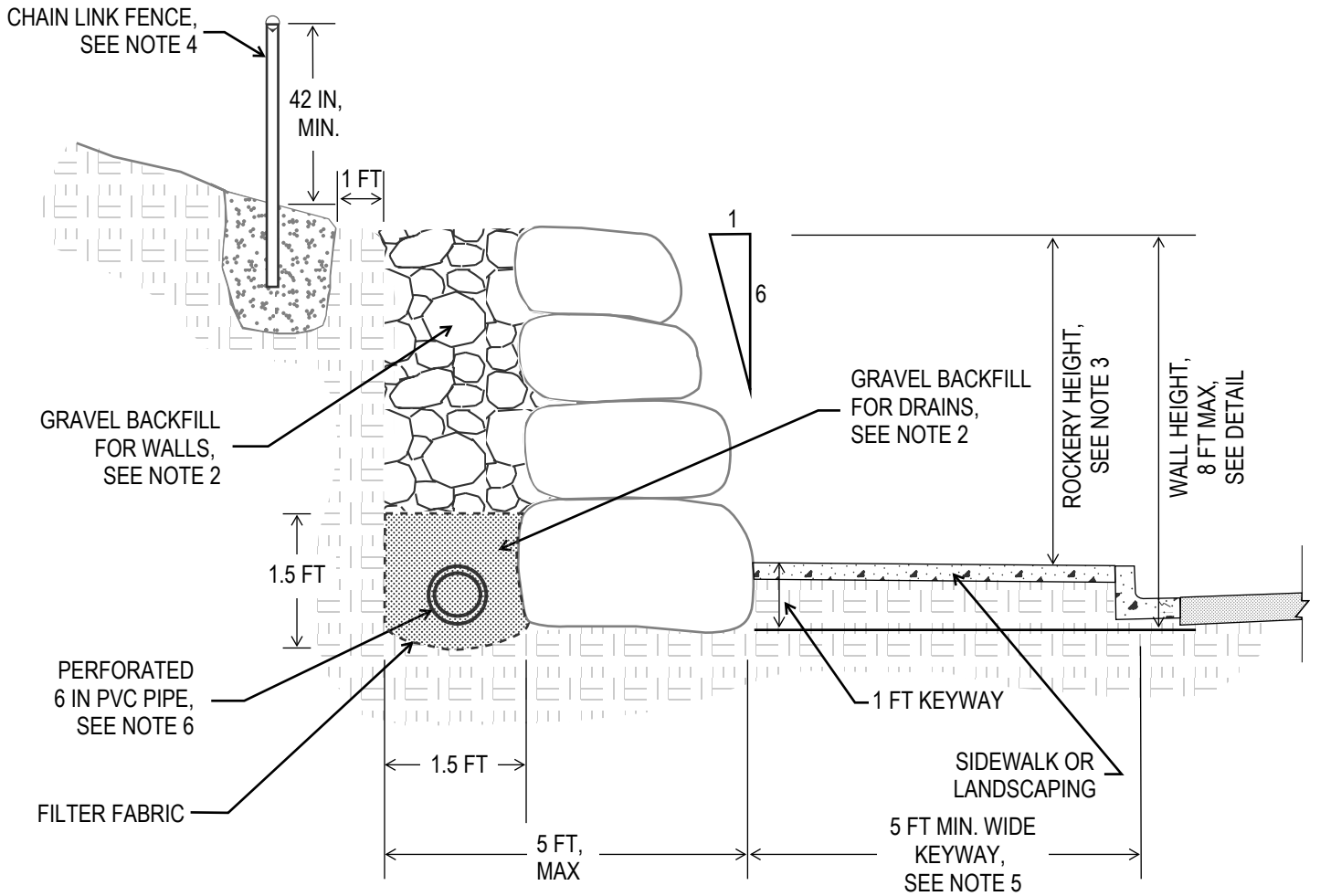

NOTES:

1. ROCK WALLS MAY ONLY BE INSTALLED ON PRIVATE PROPERTY AND MAY NOT BE USED TO SUPPORT/PROTECT ANY PUBLIC SIDEWALK OR ROADWAY.
2. SEE WSDOT STANDARD SPECIFICATIONS 9-03.12.
3. WALL HEIGHTS IN EXCESS OF 4 FEET WILL REQUIRE REVIEW AND APPROVAL FROM A LICENSED GEOTECHNICAL OR STRUCTURAL ENGINEER.
4. A FENCE MAY BE REQUIRED AS DIRECTED BY THE CITY AT BACK OF WALL FOR ROCKERY HEIGHT IN EXCESS OF 30 INCHES.
5. ROCK WALL SHALL BE PLACED A MINIMUM OF 10 FEET FROM TRAVEL LANE IF ROLLED CURB IS USED.
6. DRAIN PIPE MAY BE ELIMINATED IF RECOMMENDED BY THE DESIGN ENGINEER AND APPROVED BY THE CITY.
7. WALLS MAY BE CONSIDERED SEPERATE AND NOT TIERED IF SPACING, A, BETWEEN TIERED WALLS IS 2X GREATER THAN THE INDIVIDUAL HEIGHT OF ANY INDIVIDUAL WALLL, AS APPROVED BY A LICENSED GEOTECHNICAL OR STRUCTURAL ENGINEER.

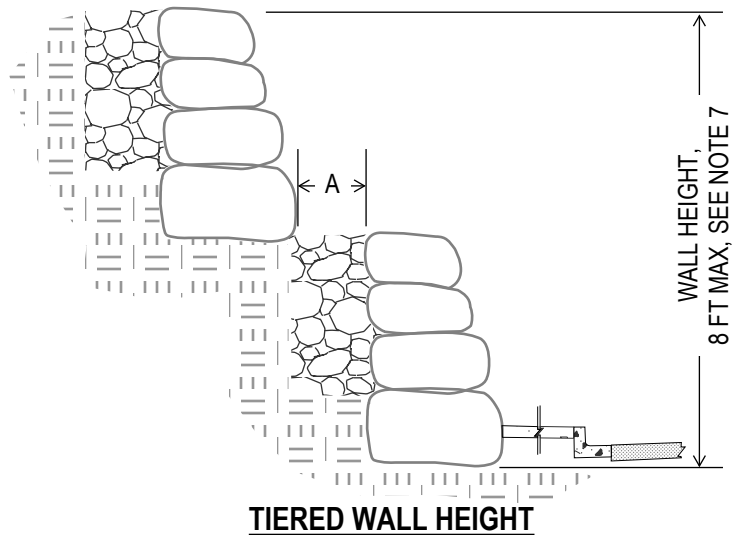

CITY OF KENMORE

ENGINEERING DEPARTMENT
(425) 398-8900



**ROCK WALL -
CUT SECTION**

**FIGURE 3-001
NOT TO SCALE**

Date: 05/19/2023

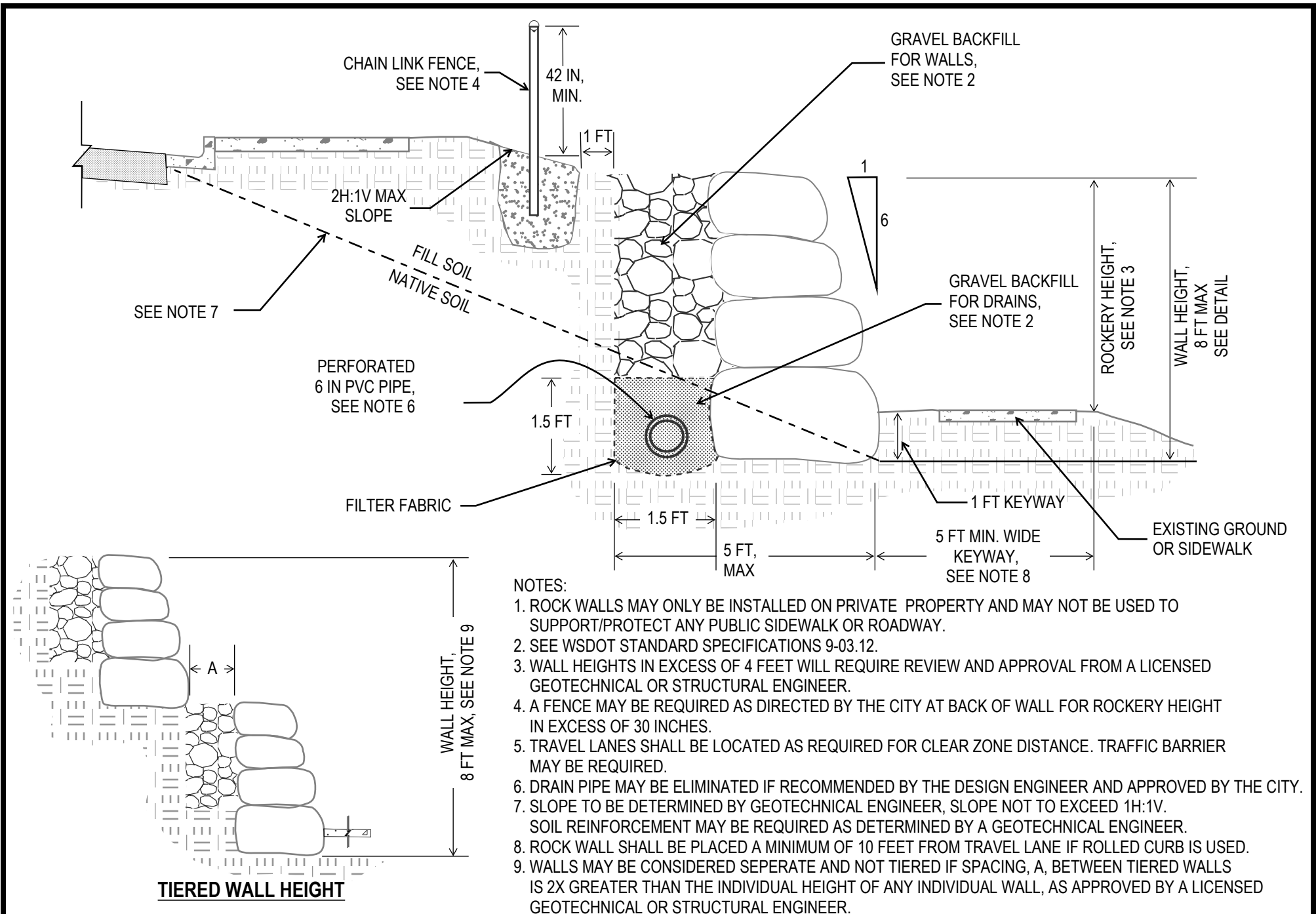

CITY OF KENMORE

ENGINEERING DEPARTMENT
(425) 398-8900



**Rock Wall
Fill Section**

FIGURE 3-002

NOT TO SCALE

Date: 5/19/2023

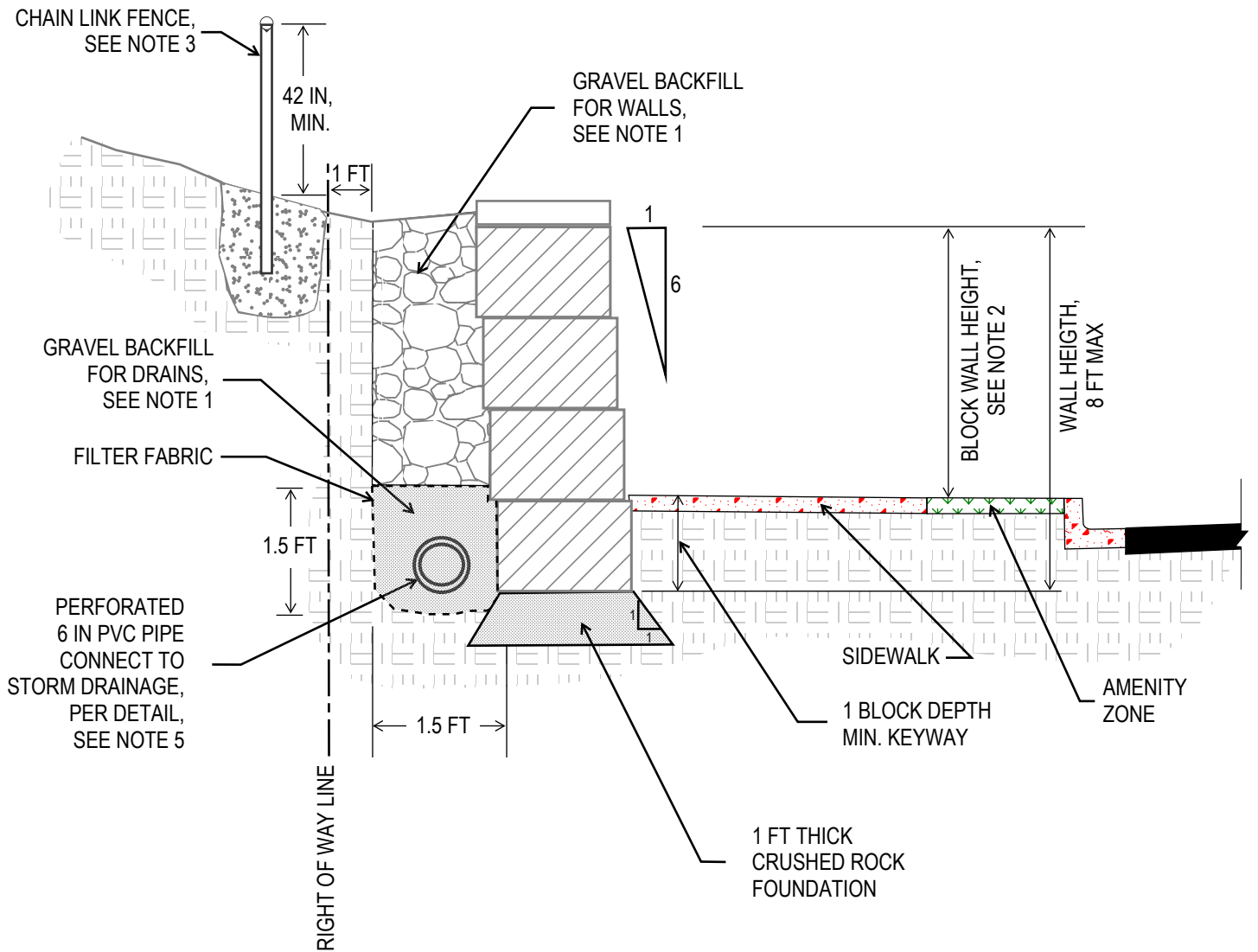

NOTES:

1. SEE WSDOT STANDARD SPECIFICATIONS 9-03.12.
2. WALL HEIGHTS IN EXCESS OF 4 FEET WILL BE REQUIRED TO BE DESIGNED BY A LICENSED PROFESSIONAL ENGINEER AND APPROVED BY THE CITY.
3. A FENCE MAY BE REQUIRED AS DIRECTED BY THE CITY AT BACK OF WALL FOR BLOCK WALL HEIGHT IN EXCESS OF 30 INCHES.
4. BLOCK WALL SHALL HAVE A TOP CAP ADHERED TO THE TOP BLOCK PER MANUFACTURER'S RECOMMENDATION
5. STORM DRAINAGE CONNECTION MAY BE ELIMINATED AT THE DISCRETION OF THE CITY ENGINEER FOR WALL HEIGHT LESS THAN 4 FEET AND WHERE SUBGRADE SOIL INFILTRATION RATES ARE GREATER THAN 1 INCH PER HOUR.
6. TIERED WALLS ARE NOT ALLOWED UNLESS APPROVED BY THE CITY ENGINEER.

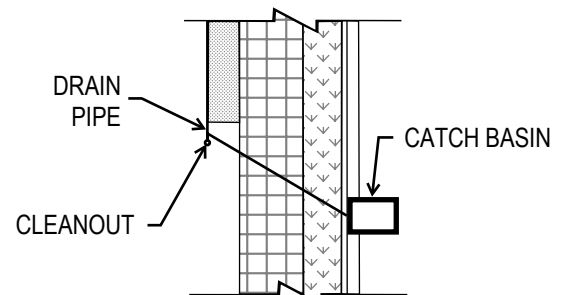

DRAIN CONNECTION DETAIL



CITY OF KENMORE

ENGINEERING DEPARTMENT
(425) 398-8900



**BLOCK WALL -
CUT SECTION**

FIGURE 3-003

NOT TO SCALE

Date: 5/19/2023

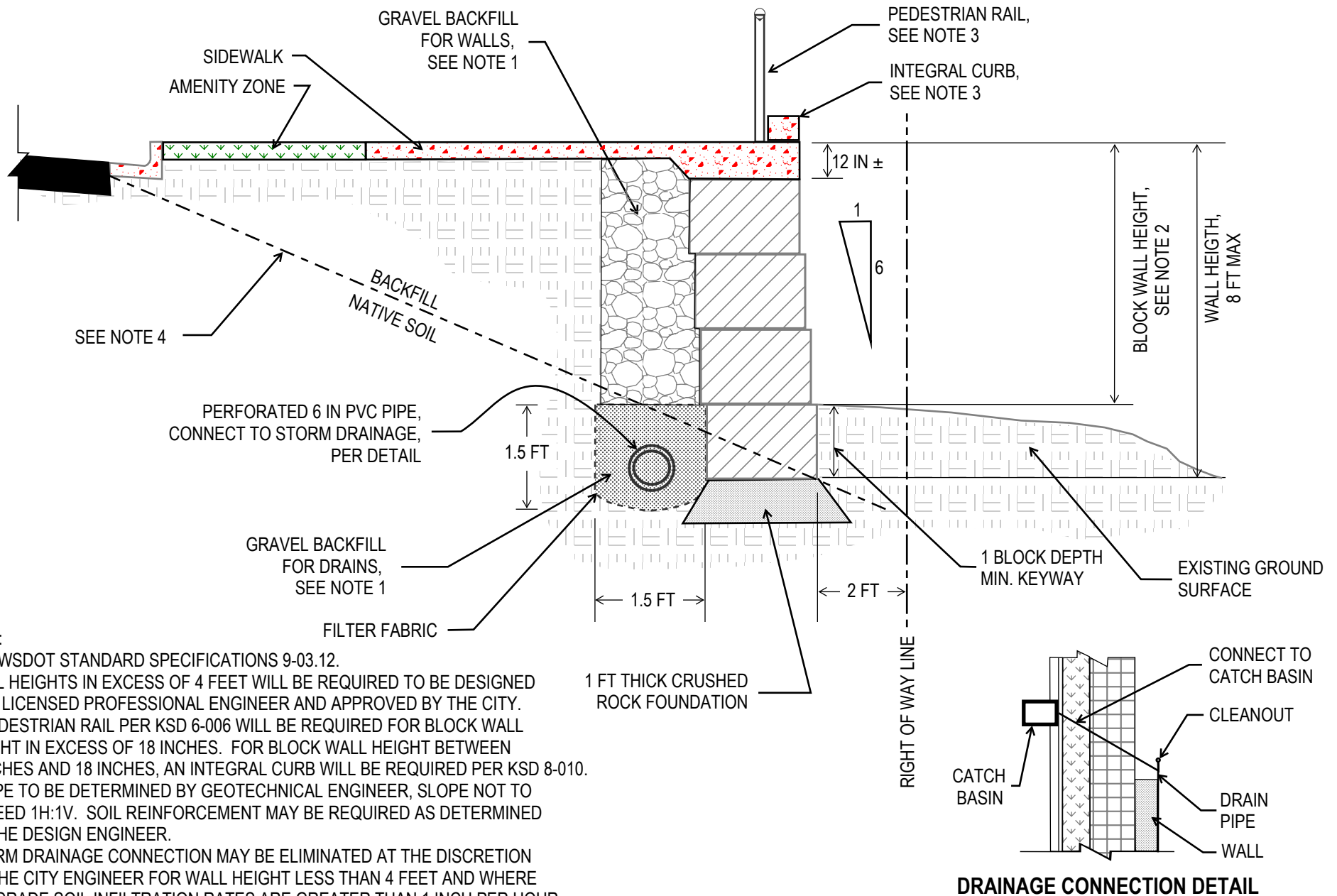

NOTES:

1. SEE WSDOT STANDARD SPECIFICATIONS 9-03.12.
2. WALL HEIGHTS IN EXCESS OF 4 FEET WILL BE REQUIRED TO BE DESIGNED BY A LICENSED PROFESSIONAL ENGINEER AND APPROVED BY THE CITY.
3. A PEDESTRIAN RAIL PER KSD 6-006 WILL BE REQUIRED FOR BLOCK WALL HEIGHT IN EXCESS OF 18 INCHES. FOR BLOCK WALL HEIGHT BETWEEN 6 INCHES AND 18 INCHES, AN INTEGRAL CURB WILL BE REQUIRED PER KSD 8-010.
4. SLOPE TO BE DETERMINED BY GEOTECHNICAL ENGINEER, SLOPE NOT TO EXCEED 1H:1V. SOIL REINFORCEMENT MAY BE REQUIRED AS DETERMINED BY THE DESIGN ENGINEER.
5. STORM DRAINAGE CONNECTION MAY BE ELIMINATED AT THE DISCRETION OF THE CITY ENGINEER FOR WALL HEIGHT LESS THAN 4 FEET AND WHERE SUBGRADE SOIL INFILTRATION RATES ARE GREATER THAN 1 INCH PER HOUR
6. TIERED WALLS ARE NOT ALLOWED UNLESS OTHERWISE APPROVED BY THE CITY ENGINEER.

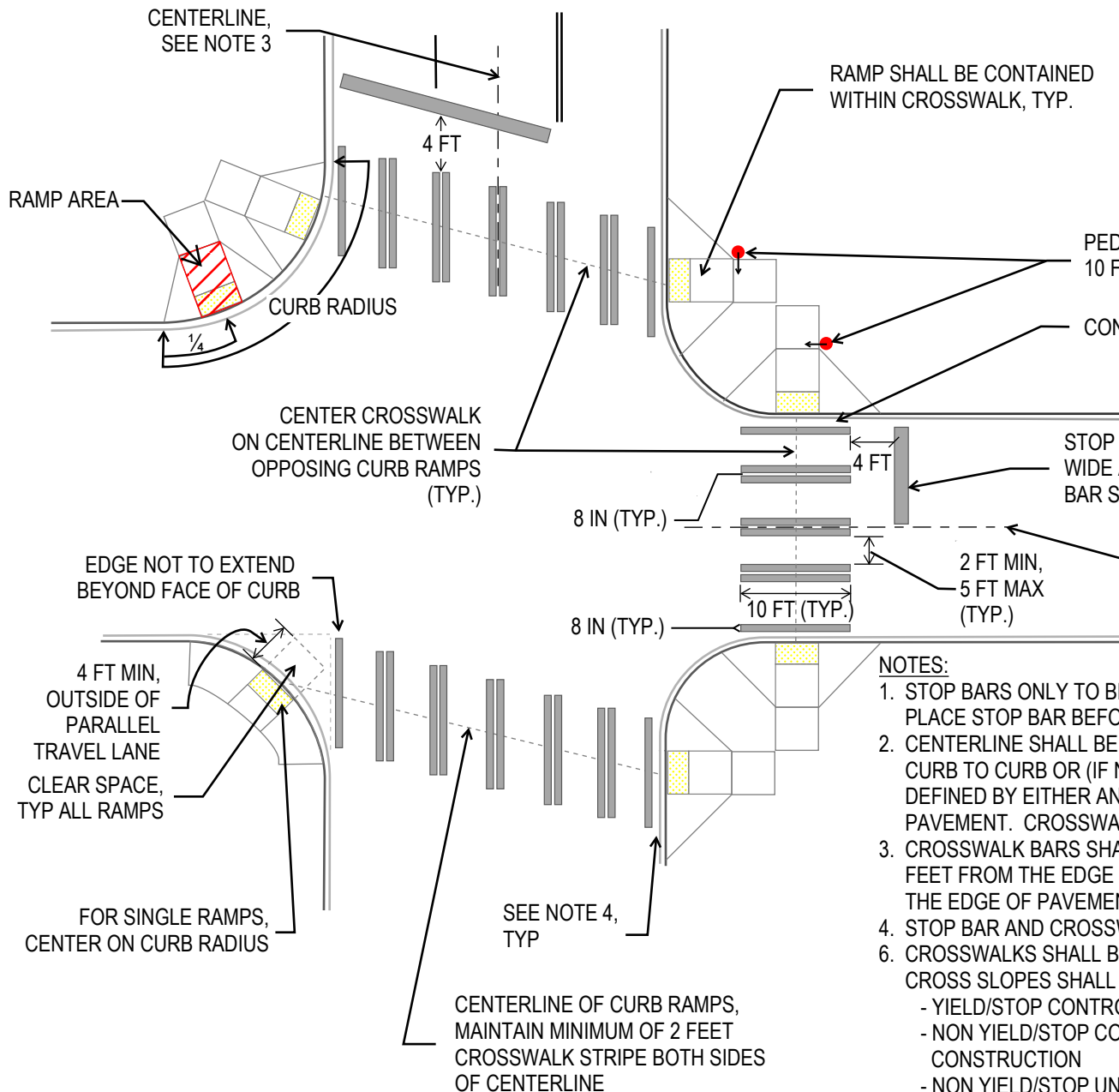

CURB RAMP LOCATION	
CURB RADIUS	LOCATION
<25 FT	INSIDE EDGE OF RAMP AT CURB RETURN
>= 25 FT	CENTER RAMP AT ¼ DELTA OF CURB RETURN
SINGLE RAMP	CENTER RAMP AT ½ DELTA OF CURB RETURN

- NOTES:**
1. STOP BARS ONLY TO BE USED AT STOP SIGNS AND SIGNALS. IF NO CROSSWALK PLACE STOP BAR BEFORE RAMP.
 2. CENTERLINE SHALL BE THE CENTER OF THE ROADWAY MEASURED FROM CURB TO CURB OR (IF NO CURB) FROM THE EDGE OF THE TRAVEL LANE AS DEFINED BY EITHER AN EDGE STRIPE OR 1 FOOT OFF OF THE EDGE OF PAVEMENT. CROSSWALK STRIPE SHALL BE CENTERED ON LINE AS SHOWN
 3. CROSSWALK BARS SHALL BE LOCATED A MINIMUM OF 1 FOOT/MAXIMUM OF 2 FEET FROM THE EDGE OF THE GUTTER, FROM THE EDGE STRIPE, OR FROM THE EDGE OF PAVEMENT IF NO EDGE STRIPE.
 4. STOP BAR AND CROSSWALK TO BE TYPE A OR D PLASTIC
 6. CROSSWALKS SHALL BE DESIGNED WITH A 5.0% MAXIMUM RUNNING SLOPE. CROSS SLOPES SHALL BE AS FOLLOWS:
 - YIELD/STOP CONTROLLED CROSSING: 2.0% MAXIMUM
 - NON YIELD/STOP CONTROLLED CROSSING: 5.0% MAXIMUM FOR NEW CONSTRUCTION
 - NON YIELD/STOP UNCONTROLLED CROSSING: MATCH SLOPE OF ROAD FOR ALTERATIONS
 - MID-BLOCK CROSSINGS: MATCH SLOPE OF ROAD



CITY OF KENMORE

ENGINEERING DEPARTMENT
(425) 398-8900



CROSSWALK AND STOP BAR MARKINGS

FIGURE 4-001

NOT TO SCALE

Date: 05/19/2023

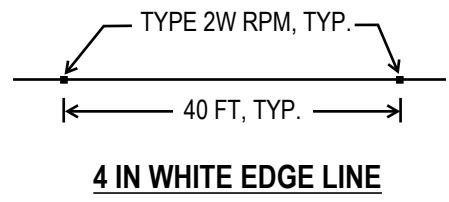
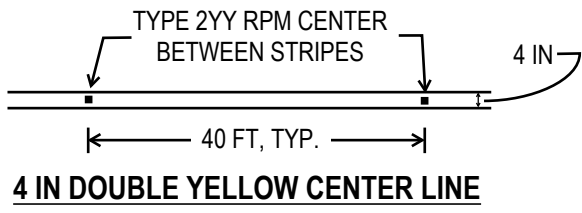
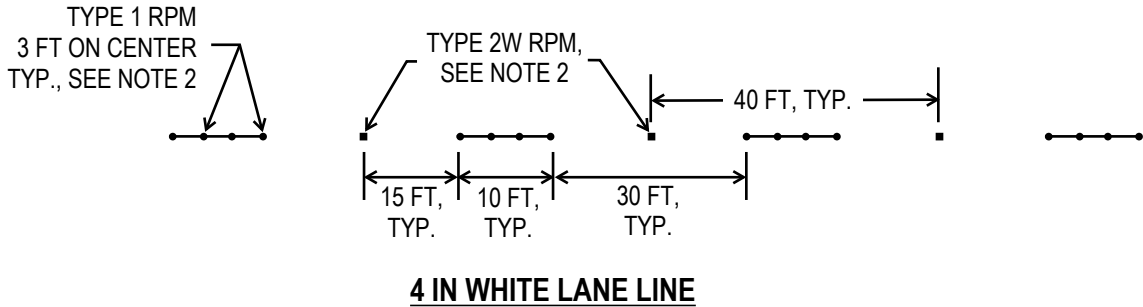

NOTES:

1. CENTER LINE MARKINGS SHALL BE PLACED ON ALL PAVED ARTERIALS AND COLLECTORS AND AT OTHER LOCATIONS AS DETERMINED BY THE CITY ENGINEER. CENTER LINE MARKINGS SHALL ALSO BE PLACED ON ALL PAVED TWO-WAY STREETS OR HIGHWAYS THAT HAVE THREE OR MORE LANES FOR MOVING MOTOR VEHICLE TRAFFIC.
2. RAISED PAVEMENT MARKERS (RPM) COLOR SHALL MATCH COLOR OF COORESPONDING PAVEMENT MARKINGS. TYPE 1 RPM SHALL BE INSTALLED PRIOR TO ANY PAINT LINE, EXISTING CHANNELIZATION SHALL BE REMOVED PRIOR TO INSTALLING THE RPM.
3. WHITE EDGE LINES SHALL BE INSTALLED ON ALL ROADS AS DIRECTED BY THE CITY ENGINEER.
4. SEE KSD 4-003 (LEFT TURN LANES), 4-004 (BIKE LANES) STRIPING REQUIREMENTS
5. A 4 IN WHITE EDGE LINE MAY BE REQUIRED ADJACENT TO CURB AS DIRECTED BY THE CITY.
6. ALL ARROWS AND LETTERING SHALL BE PER WSDOT STANDARD DETAIL M-24.40-02, M-80.10-01 AND M-80.30-00.

Y: Yellow on one side facing traffic flow
 YY: Yellow on both sides
 W: White on one side facing traffic flow



CITY OF KENMORE
 ENGINEERING DEPARTMENT
 (425) 398-8900



**Roadway
 Channelization**

FIGURE 4-002
 NOT TO SCALE
 Date: 05/19/2023

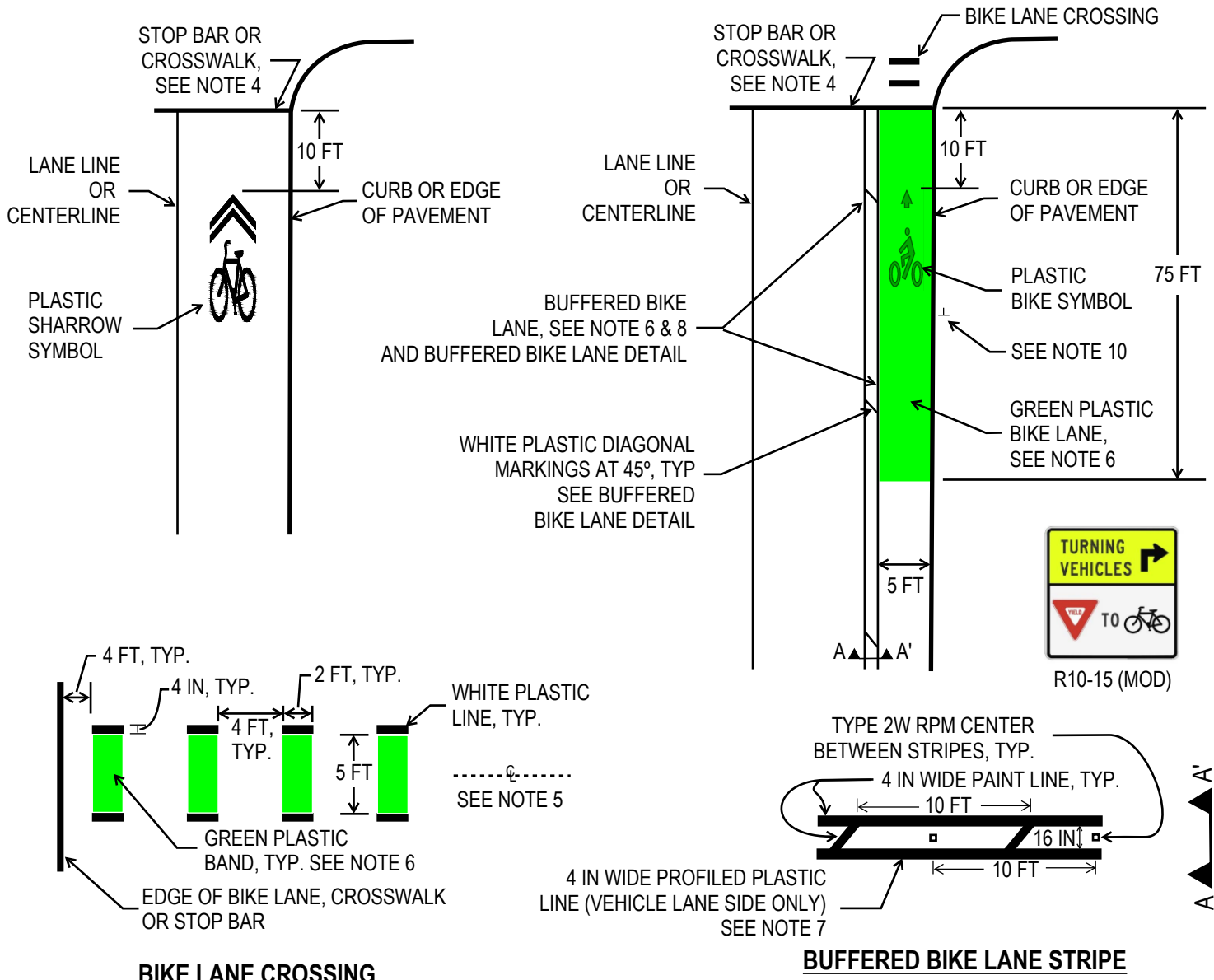

BIKE LANE CROSSING

BUFFERED BIKE LANE STRIPE

NOTES:

1. BIKE LANE SYMBOL PER WSDOT STANDARD DETAIL M-9.50-02
2. SPACE BIKE LANE AND SHARROW SYMBOLS EVERY 300± FEET, CENTER ON LANE.
3. SEE KSD 4-002 FOR LANE LINE REQUIREMENTS
4. FOR LOCATIONS WITH NO STOP BAR OR CROSSWALK, MEASURE FROM START OF CURB RADIUS OR PAVEMENT RADIUS. WHERE CROSSWALK EXISTS, PLACE BIKE LANE CROSSING BETWEEN CROSSWALK MARKINGS ONLY.
5. ALIGN CENTER OF BIKE LANE CROSSING WITH BIKE LANE
6. GREEN COLOR SHALL MEET THE REQUIREMENTS OF THE WSDOT STANDARD SPECIFICATIONS AND MUTCD. PLASTIC PER WSDOT STANDARD SPECIFICATIONS. SEE THE ROAD STANDARDS FOR ADDITIONAL REQUIREMENTS.
7. PROFILED PLASTIC LINE PER WSDOT STANDARD DETAIL M-20.20-02.
8. PROVIDE 2-FOOT LONG SKIP STRIPE IN FRONT OF DRIVEWAYS. 2-FOOT SPACING BETWEEN STRIPES.
9. ALL PLASTIC SHALL BE TYPE D PER WSDOT 9-34.3(4).
10. INSTALL R10-15 (MOD) SIGN APPROXIMATELY MIDDLE OF GREEN BIKE LANE PER KSD 6-002.

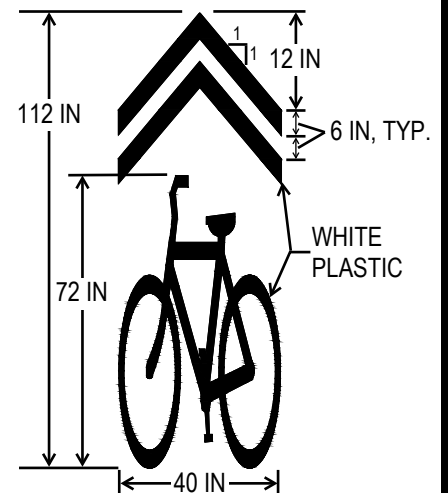

SHARROW SYMBOL



CITY OF KENMORE

ENGINEERING DEPARTMENT
(425) 398-8900



BIKE LANES

FIGURE 4-004

NOT TO SCALE

Date: 05/19/2023

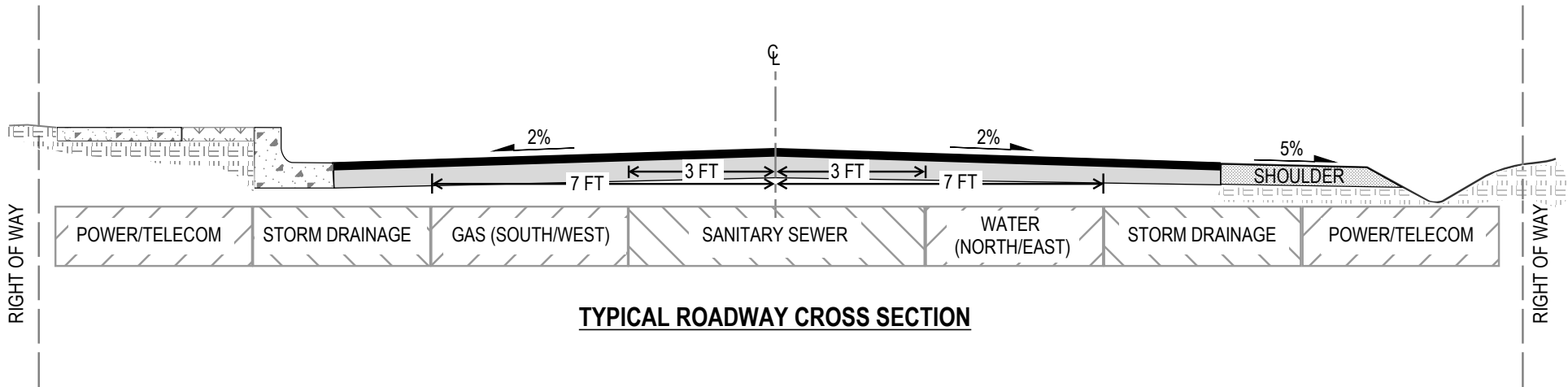

TYPICAL ROADWAY CROSS SECTION

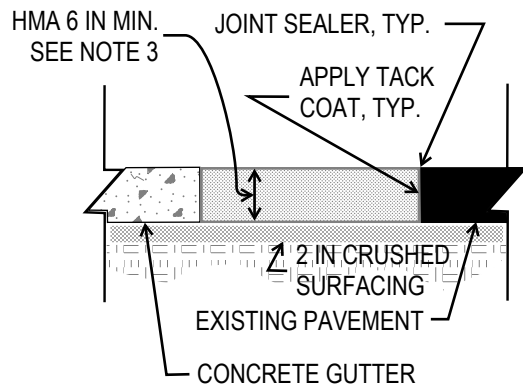

FULL DEPTH SECTION

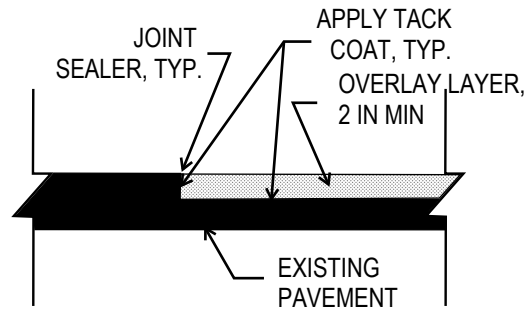

OVERLAY SECTION

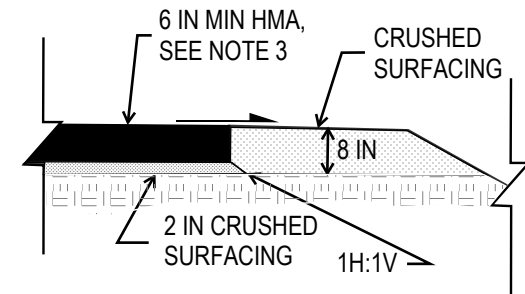

SHOULDER SECTION

NOTES:

1. CRUSHED SURFACING MAY BE TOP OR BASE COURSE, SEE WSDOT STANDARD SPECIFICATIONS.
2. ADDITIONAL EXCAVATION AND GRAVEL BACKFILL MAY BE REQUIRED DEPENDING UPON SUBGRADE CONDITIONS AS DETERMINED BY A GEOTECHNICAL ENGINEER OR THE CITY.
3. HOT MIX ASPHALT (HMA) PER WSDOT STANDARD SPECIFICATIONS. HMA SHALL BE CLASS ½ INCH. CLASS ¾ INCH MAY BE USED IN LIFTS BELOW THE TOP 2 INCHES OF PAVEMENT. HMA THICKNESS TO MATCH EXISTING ADJACENT PAVEMENT THICKNESS IF THICKER THAN 6 INCHES.
4. ALL FINAL ELEVATIONS SHALL MEET AND MATCH TO ADJACENT GUTTER, SHOULDER, UTILITY LIDS, ETC.
5. ALL UTILITY LIDS ARE TO BE ADJUSTED TO FINAL ROADWAY GRADE.
6. WATER METERS TO BE LOCATED AT THE EDGE OF THE RIGHT OF WAY LINE IN THE PUBLIC RIGHT OF WAY. ANY METERS PLACED WITHIN THE SIDEWALK SHALL HAVE A SKID RESISTENT LID AND MEET ADA REQUIREMENTS.
7. ALL MATERIALS TO BE PLACED PER KENMORE ROAD STANDARDS.



CITY OF KENMORE

ENGINEERING DEPARTMENT
(425) 398-8900



ROADWAY CROSS SECTION

FIGURE 5-001

NOT TO SCALE

Date: 05/19/2023

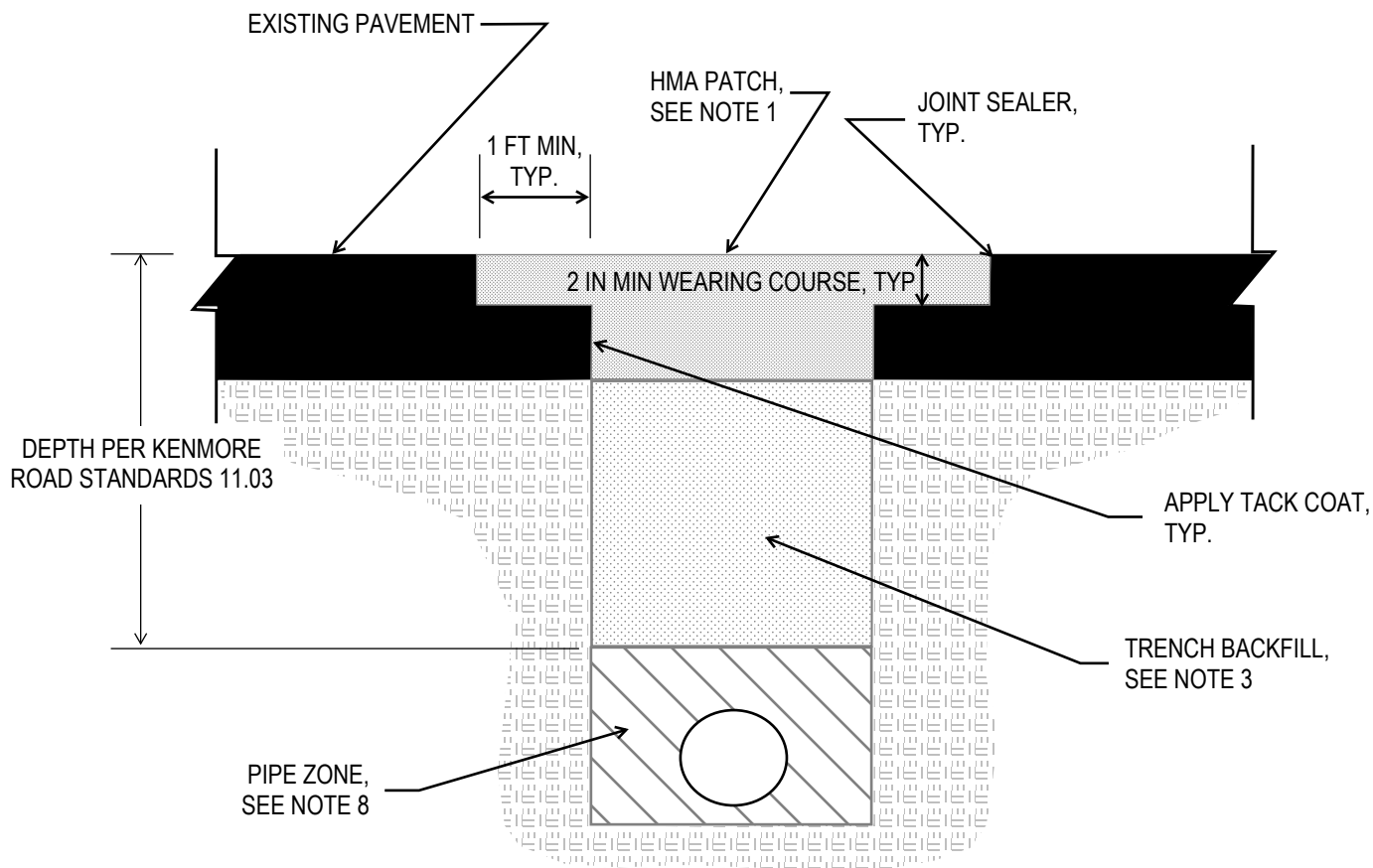

NOTES:

1. HOT MIX ASPHALT (HMA) PER WSDOT STANDARD SPECIFICATIONS. HMA SHALL BE CLASS ½ INCH. CLASS ¾ INCH MAY BE USED IN LIFTS BELOW THE WEARING COURSE. HMA THICKNESS TO MATCH EXISTING ADJACENT PAVEMENT THICKNESS BUT MUST HAVE A MINIMUM THICKNESS OF 6 INCHES
2. SAWCUT LINES SHALL BE NEAT AND CLEAN PRIOR TO PAVING. OVER CUTTING MAY BE REQUIRED TO PROVIDE A NEAT SAWCUT LINE AFTER TRENCH WORK IS COMPLETED.
3. ALL BACKFILL SHALL BE PER THE KENMORE ROAD STANDARDS 11.04C.
4. ADDITIONAL WIDTH MAYBE REQUIRED FOR TRENCH EXCAVATIONS GREATER THAN 10 FEET OR WHERE PAVEMENT CONDITION INDEX IS LESS THAN 60 AS DETERMINED BY THE CITY.
5. ALL MATERIALS TO BE PLACED PER THE KENMORE ROAD STANDARDS
6. ADDITIONAL PAVEMENT RESTORATION WILL BE REQUIRED FOR PAVEMENT LESS THAN 5 YEARS OLD.
7. SEE KENMORE ROAD STANDARDS FOR PIPE COVER REQUIREMENTS
8. PIPE ZONE MATERIAL SHALL BE PER KENMORE ROAD STANDARDS 11.04C AND DIMENSIONS SHALL BE PER THE RESPECTIVE UTILITY. FOR STORM DRAINAGE, SEE KSD 7-002.



CITY OF KENMORE

ENGINEERING DEPARTMENT
(425) 398-8900



TRENCH CUT

FIGURE 5-002

NOT TO SCALE

Date: 05/17/2023

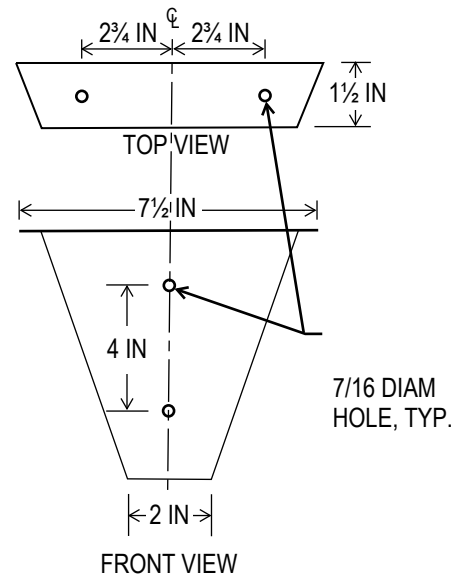
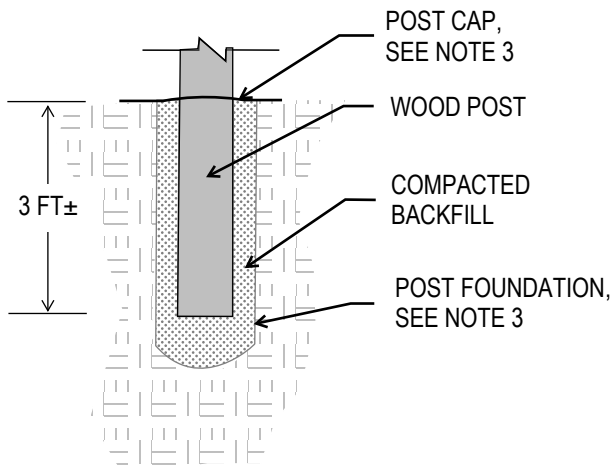
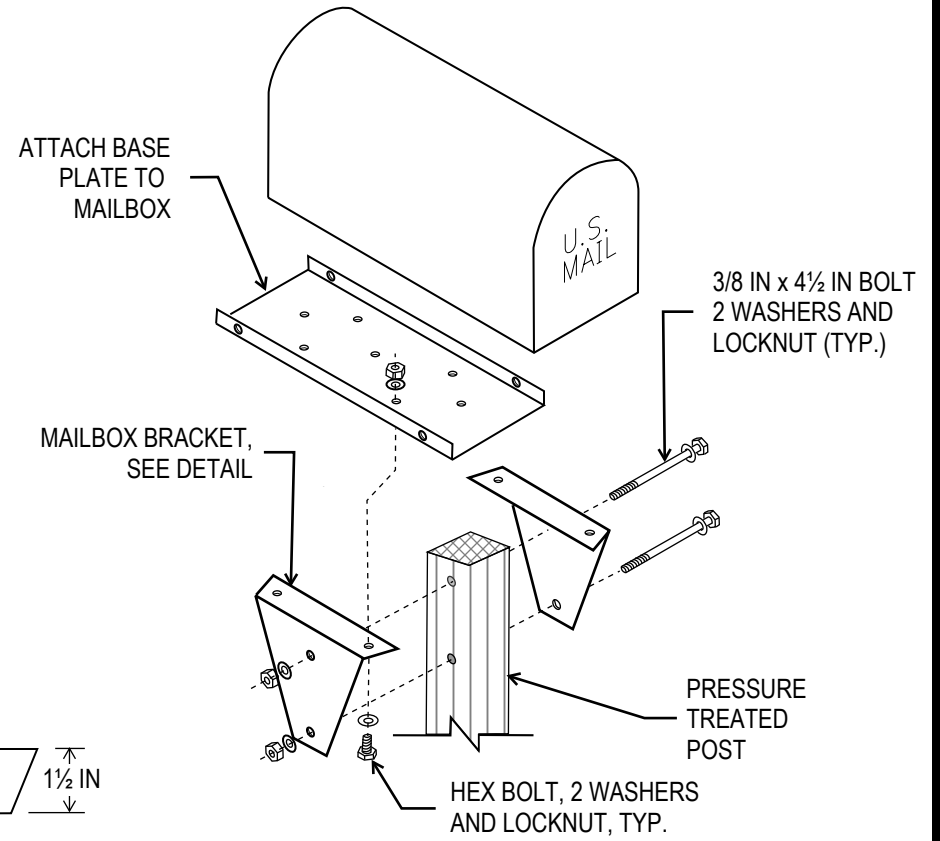
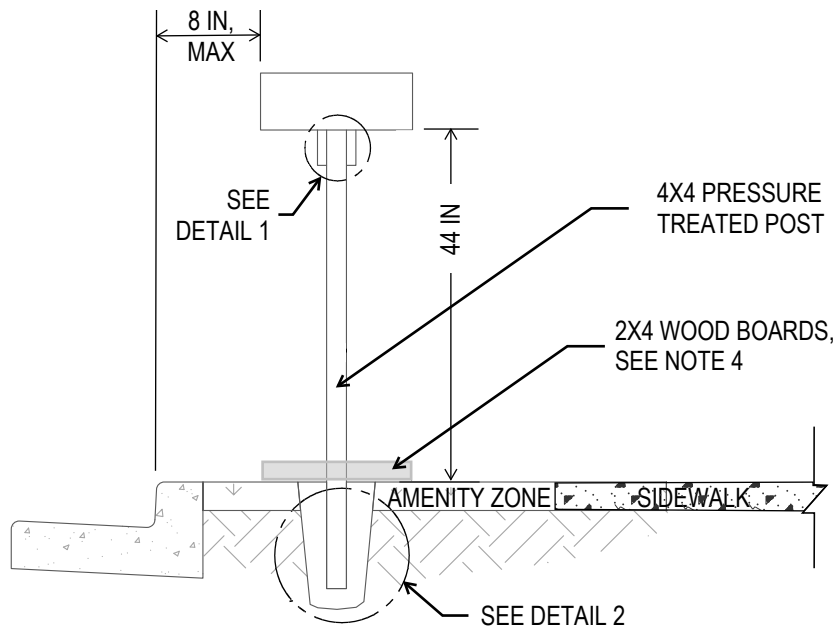

DETAIL 1

DETAIL 2

MAILBOX BRACKET DETAIL

NOTES:

1. OBTAIN LOCATION APPROVAL BY POST MASTER PRIOR TO INSTALLATION
2. FOR MAILBOX RELOCATIONS, NEW WOOD POSTS SHALL BE USED
3. SEE KSD 6-003 (POST FOUNDATION)
4. FOR MAILBOX LOCATED IN AREAS WITHOUT AMENITY ZONES, ADD 2 PRESSURE TREATED WOOD BOARDS TO THE BASE OF THE POST. BOARDS SHALL BOLTED TO THE POST AND SHALL BE THE SAME DEPTH OF THE MAILBOX.



CITY OF KENMORE

ENGINEERING DEPARTMENT
(425) 398-8900



**MAILBOX
WOOD POST**

FIGURE 6-001

NOT TO SCALE

Date: 05/19/2023

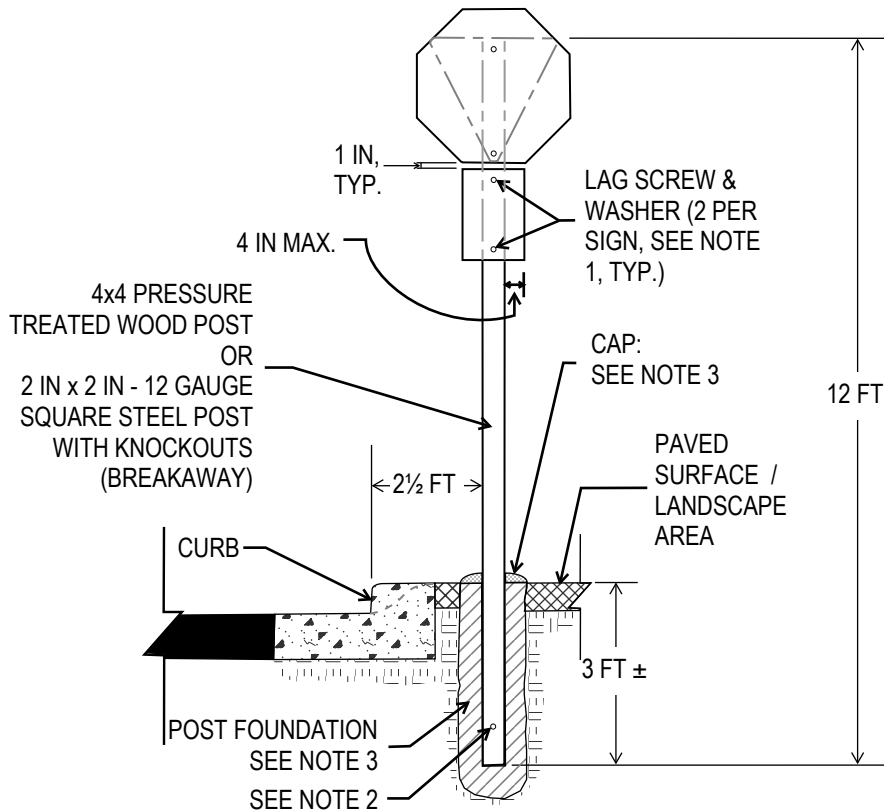

SIGN PLACEMENT ADJACENT TO CURB

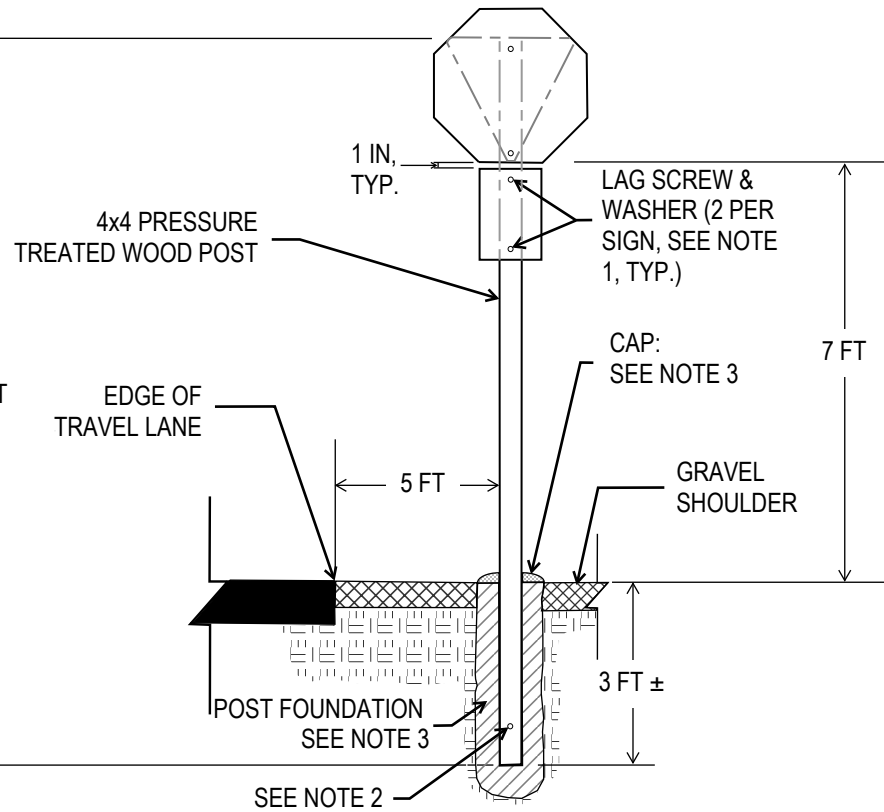

SIGN PLACEMENT IN SHOULDER

NOTES:

1. 5/16" X 3/4" GALVANIZED OR PLATED LAG SCREW & 3/8" ID X1" OD NYLON WASHER
2. INSTALL 1/2 IN DIAMETER GALVANIZED COMMON SPIKE FOR WOOD POSTS ONLY. PLACE ON THE FACE SIDE OF THE POST FOR SIGNS PLACED WITHIN LANDSCAPE OR GRAVEL AREAS. SPIKE SHALL BE 8 IN ABOVE BOTTOM OF POST AND PROTRUDE 2 IN FROM POST
3. SEE KSD 6-003 (POST FOUNDATION)
4. STEEL POST SHALL BE USED FOR SURFACE MOUNT POSTS AND FOR POSTS INSTALLED IN ADJACENT PAVED SURFACES. STEEL POSTS SHALL COME WITH KNOCKOUTS AND NOT BE "PRE-PUNCHED".
5. TOP SIGN SHALL BE MOUNTED FLUSH WITH THE TOP OF THE POST

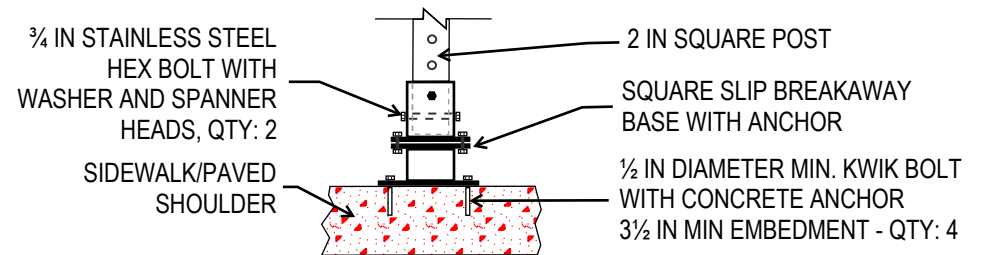

SURFACE MOUNT DETAIL



CITY OF KENMORE

ENGINEERING DEPARTMENT
(425) 398-8900



TRAFFIC SIGNS

FIGURE 6-002

NOT TO SCALE

Date: 06/21/2022

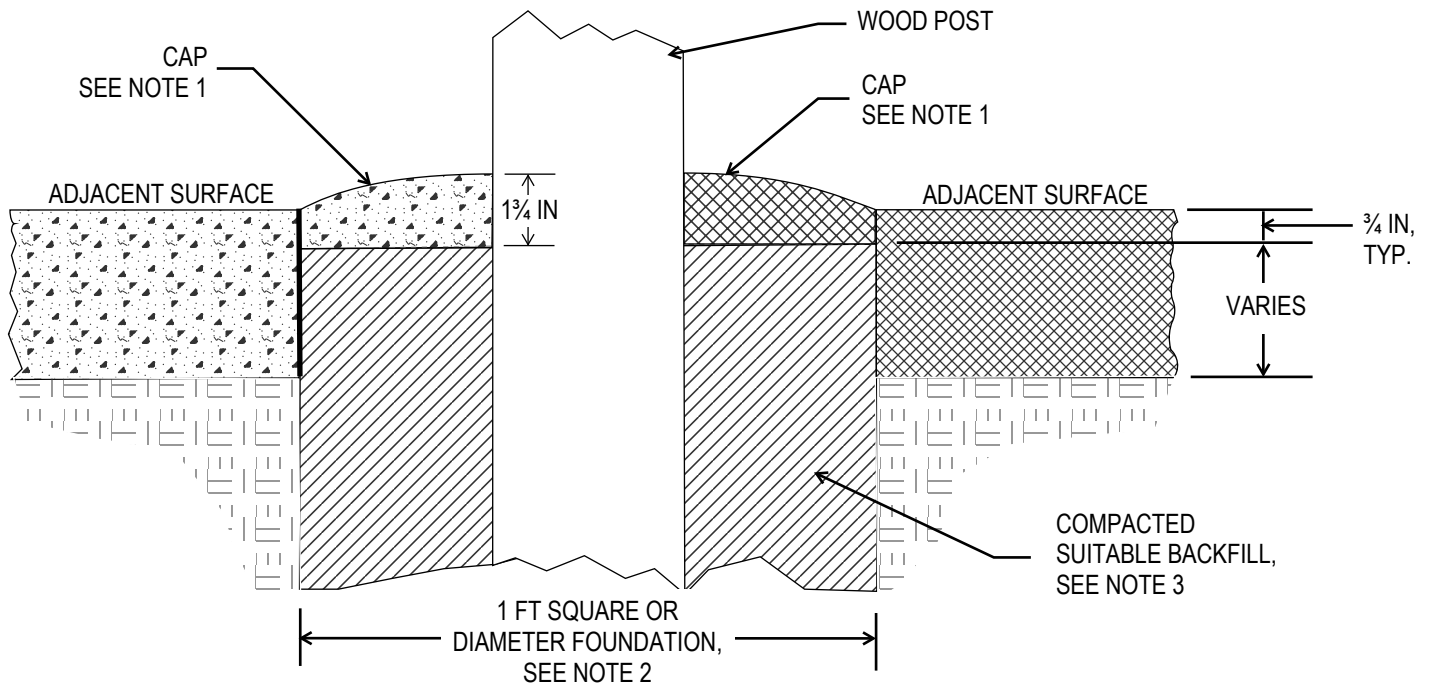

WOOD POST FOUNDATION

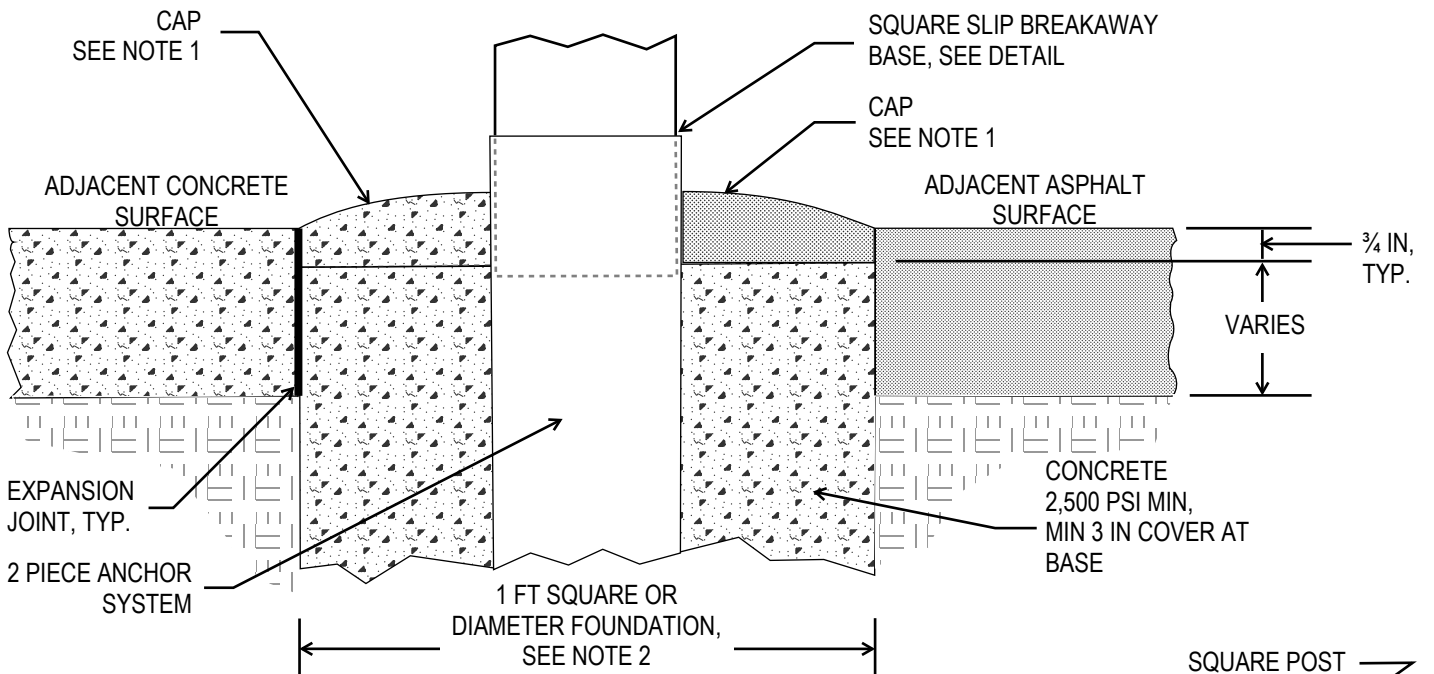

METAL POST FOUNDATION

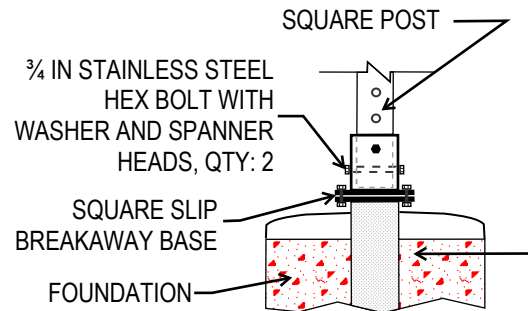

BREAKAWAY BASE DETAIL

NOTES:

1. CAP SHALL BE MADE OF THE SAME MATERIAL AS THE SURROUNDING SURFACE AND SHALL BE MOUNDED TO DRAIN AWAY FROM POST.
2. BLOCKOUTS SHALL BE PROVIDED FOR POST LOCATIONS WHERE NEW CONCRETE PAVEMENT SURROUNDS POST
3. BACKFILL MATERIAL SHALL BE SELECT BORROW OR GRAVEL BORROW PER WSDOT STANDARD SPECIFICATIONS 9-03.14



CITY OF KENMORE

ENGINEERING DEPARTMENT
(425) 398-8900



POST FOUNDATION

FIGURE 6-003

NOT TO SCALE

Date: 12/31/2020

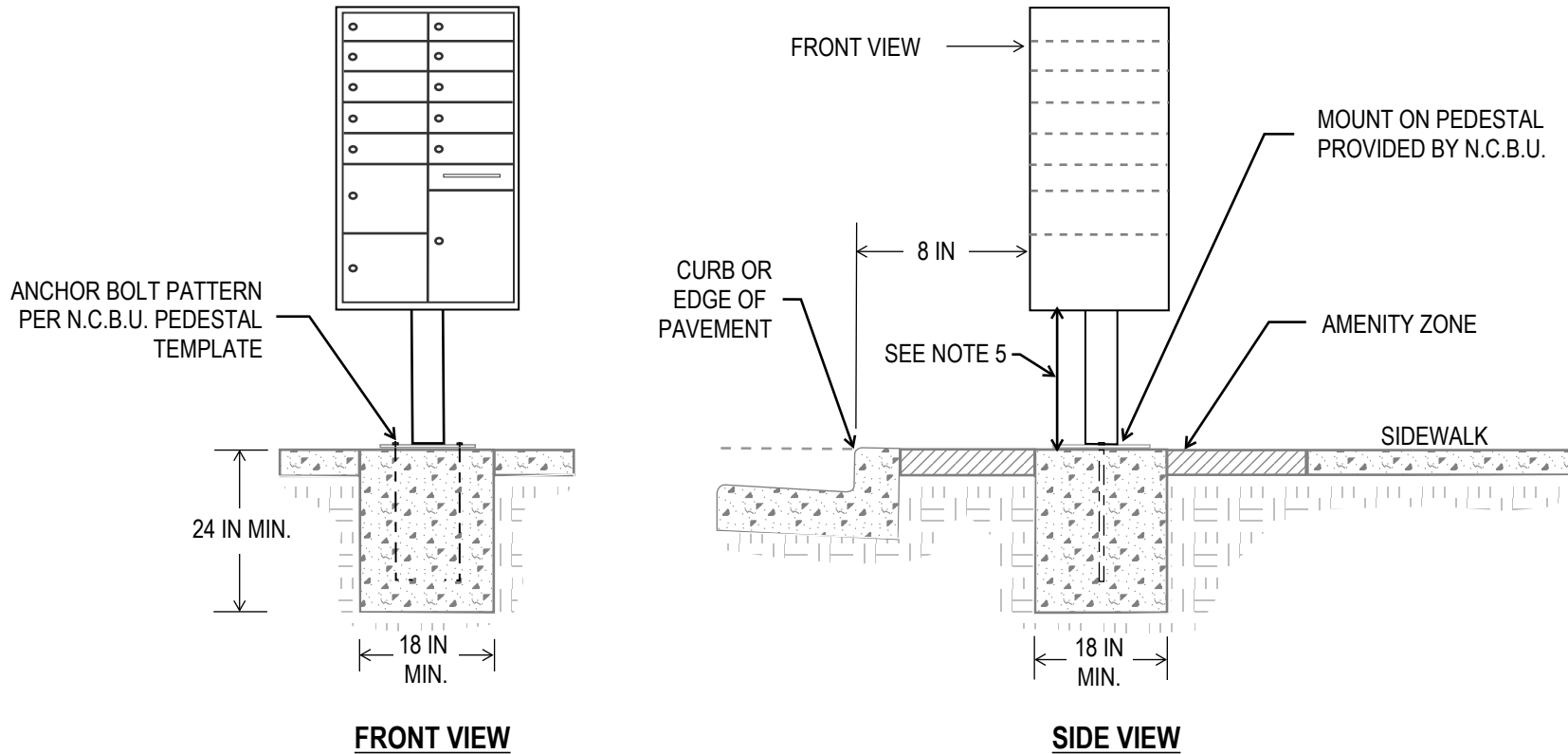

NOTES:

1. INSTALL FOUNDATION PER MANUFACTURES INSTRUCTION.
2. FOUNDATION SHALL BE MINIMUM 3000 PSI CONCRETE
3. NCBU SHALL HAVE A MINIMUM OF 1 PARCEL LOCKER
4. FOUNDATION DIMENSIONS ARE A MNUM. ACTUAL DIMENSIONS OF FOUNDATION WILL BE PER MANUFACTURES DIRECTION.
5. NCBUs LOCATED IN AREAS WITHOUT AMENITY ZONES, MAXIMUM IS 27 IN.

* N.C.B.U. -- NEIGHBORHOOD COLLECTION BOX UNIT



CITY OF KENMORE

ENGINEERING DEPARTMENT
(425) 398-8900



**MAILBOX
COLLECTION BOX UNIT**

FIGURE 6-004

NOT TO SCALE

Date: 06/21/2022

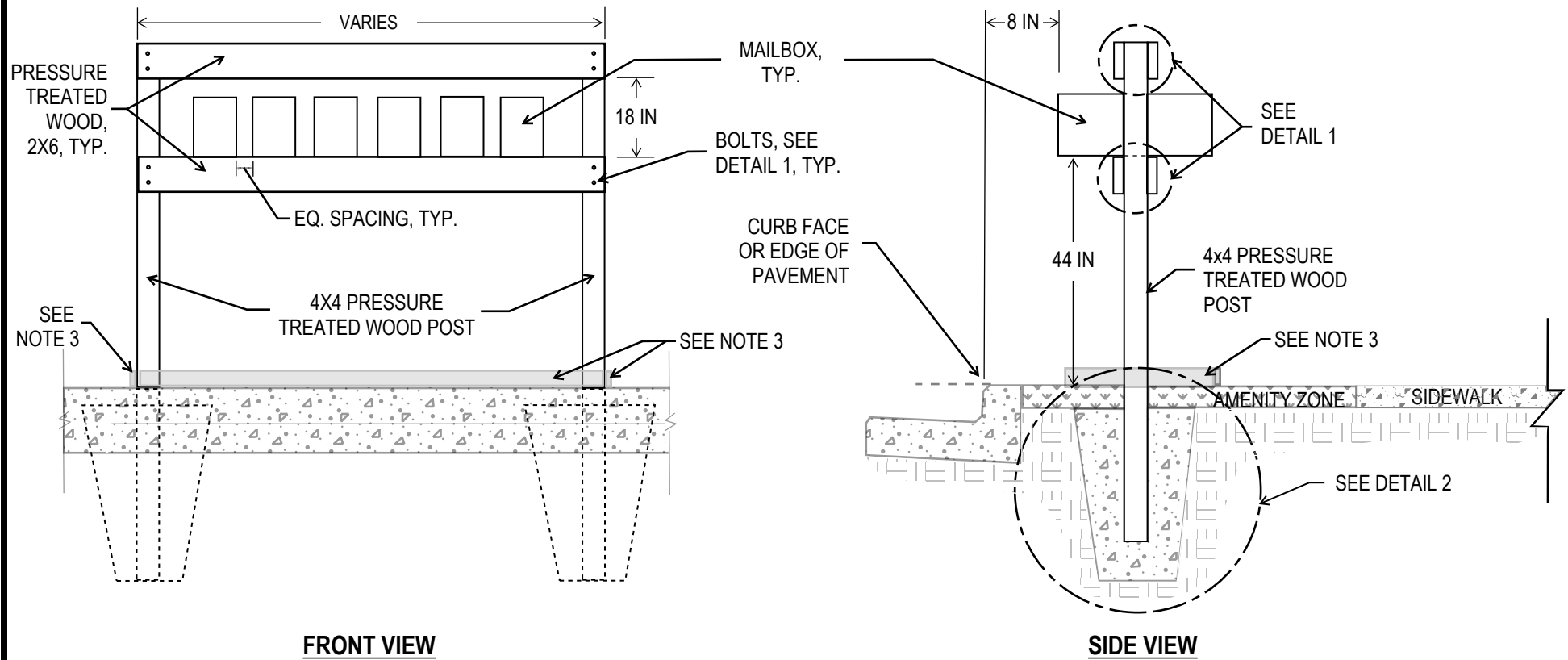

NOTES:

1. OBTAIN LOCATION APPROVAL BY POST MASTER PRIOR TO INSTALLATION
2. FOR MAILBOX RELOCATIONS, NEW WOOD POSTS SHALL BE USED
3. FOR MAILBOX LOCATED IN AREAS WITHOUT AMENITY ZONES, ADD 1 - 2X4 PRESSURE TREATED WOOD BOARD TO THE BASE OF EACH POST AND 1 BOARD ALONG THE SIDEWALK SIDE. BOARDS SHALL BE ATTACHED TO THE POST AND SHALL BE THE SAME DEPTH OF THE DEEPEST MAILBOX.

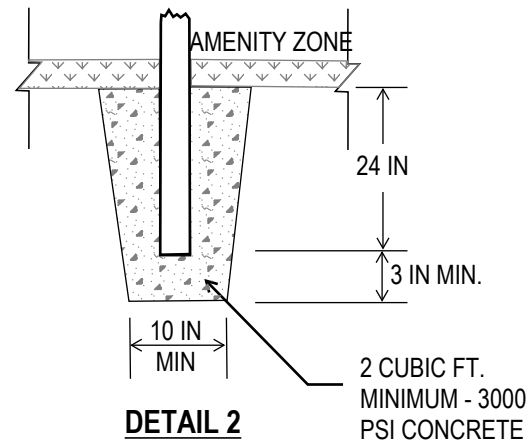
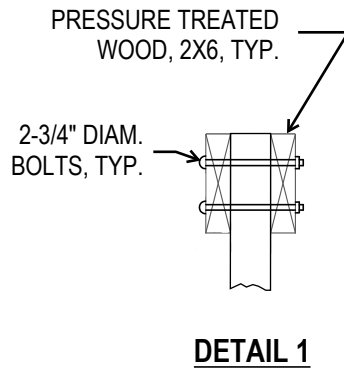

CITY OF KENMORE

ENGINEERING DEPARTMENT
(425) 398-8900



**MAILBOX
CLUSTER**

FIGURE 6-005

NOT TO SCALE

Date: 05/19/2023

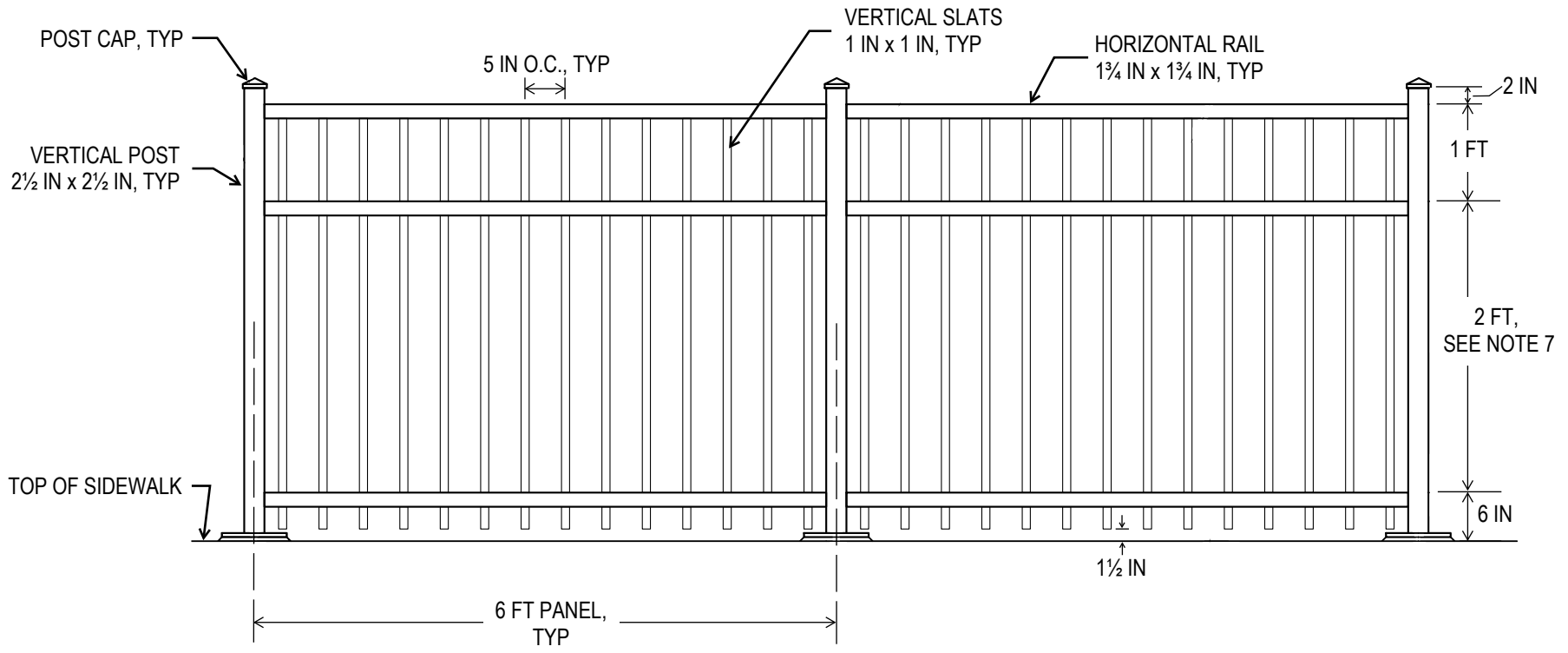

NOTES:

1. FENCE MATERIAL SHALL BE 14 GAUGE HOT DIPPED GALVANIZED STEEL IN ACCORDANCE WITH ASTM A653-A653M WITH A MINIMUM YIELD STRENGTH OF 45,000 PSI.
2. ALL ALUMINIUM PARTS SHALL BE GIVEN A CLEAR ANODIC COATING AT LEAST 0.0006 INCH THICK AND BE HOT WATER SEALED AND SHALL HAVE A UNIFORM FINISH.
3. CUTTING SHALL BE DONE BY SAWING OR MILLING AND ALL CUTS SHALL BE TRUE AND SMOOTH. FLAME CUTTING WILL NOT BE PERMITTED.
4. WELDING OF ALUMINIUM SHALL BE IN ACCORDANCE WITH THE LATEST AASHTO STANDARDS FOR STRUCTURAL SUPPORTS FOR HIGHWAY SIGNS, LUMINAIRES, AND TRAFFIC SIGNALS.
5. ALLOW FOR EXPANSION AT APPROXIMATELY EVERY FOURTH POST.
6. 3 FEET FOR RAILING PLACED ADJACENT TO BIKE LANES WITH NO CURB SEPARATION.
7. PANELS SHALL BE A SOLID UNIT DETACHABLE FROM THE ADJACENT POSTS.
8. RAIL LOADING 50 LB OR PER CURRENT EDITION OF INTERNATIONAL BUILDING CODE, WHICHEVER IS MORE STRINGENT.
9. ALL CONCEALED FASTENERS THROUGHOUT.
10. BLACK POWDER COATED PER CURRENT ASTM STANDARDS. WELDS TO BE PAINTED TO MATCH COLOR OF POST

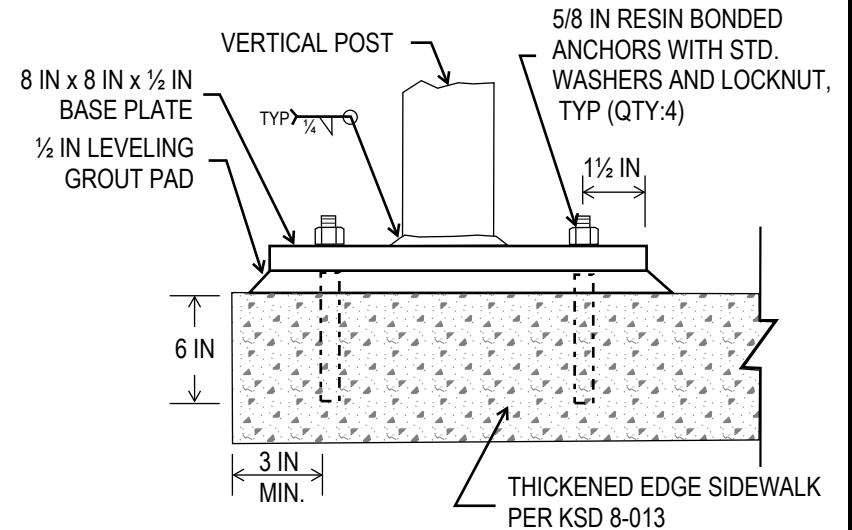

SURFACE MOUNT DETAIL



CITY OF KENMORE

ENGINEERING DEPARTMENT
(425) 398-8900



PEDESTRIAN RAILING

FIGURE 6-006

NOT TO SCALE

Date: 12/31/2020

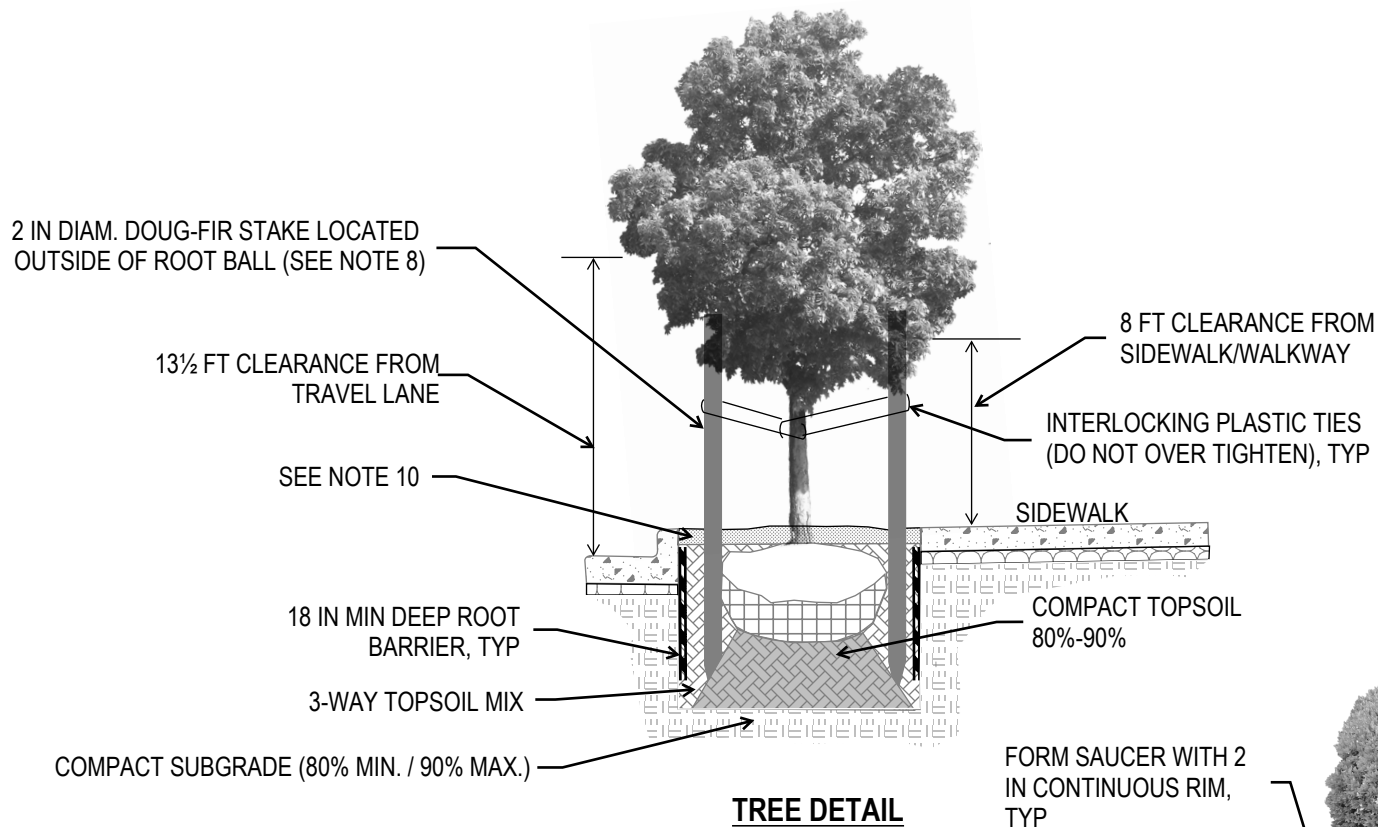

NOTES:

1. TREE PIT SHALL BE UNIFORM IN SIZE AND FULL WIDTH OF AMENITY STRIP.
2. CUT ALL TIES AND FOLD BACK BURLAP FROM UPPER 1/3 OF ROOT BALL.
3. REMOVE TREATED BURLAP OR WIRE BASKETS COMPLETELY.
4. FERTILIZE AND USE GROWTH HORMONE.
5. INSTALL WATERING BAG AT EACH TREE, TREES SHALL RECEIVE WATER DAILY UNTIL ESTABLISHED.
6. TREE LOCATION AND ORIENTATION TO BE APPROVED BY CITY.
7. ROOT BARRIER SHALL BE MINIMUM OF 10 FEET LONG CENTERED ON TREE.
8. USE GROUND ANCHORS WHERE TREES GRATES ARE INSTALLED.
9. TREE TYPE SHALL BE PER THE CITY APPROVED TREE LIST.
10. 2 IN BARK MULCH FOR LANDSCAPED AMENITY ZONES, TREE GRATE AND FRAME PER KSD 6-008 FOR PAVED AMENITY ZONES.
11. TREE CALIPER (DIAMETER) MEASUREMENTS SHALL BE TAKEN AT BREAST HEIGHT, APPROXIMATELY 4 FEET ABOVE THE SOIL HEIGHT.

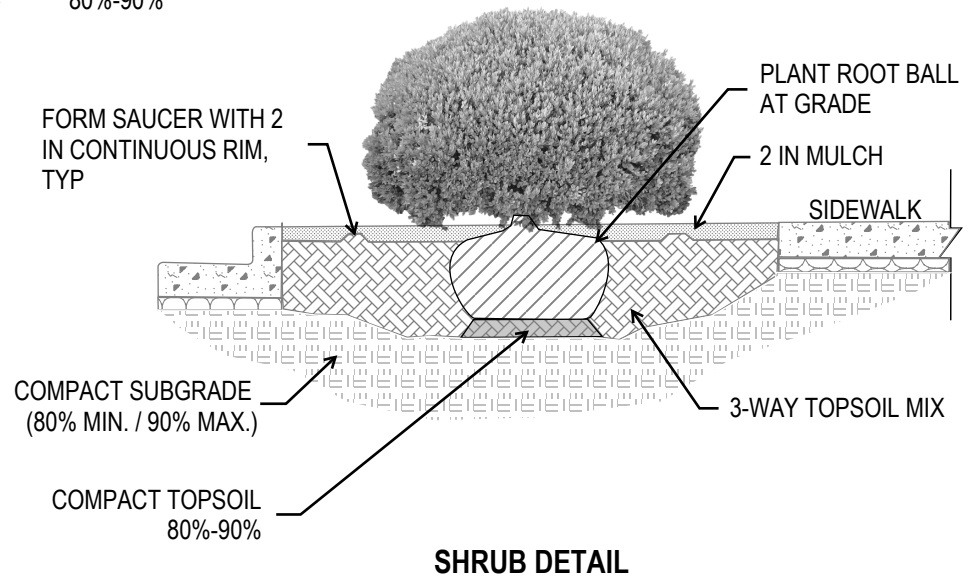

CITY OF KENMORE

ENGINEERING DEPARTMENT
(425) 398-8900



PLANTING

FIGURE 6-007

NOT TO SCALE

Date: 05/19/2023

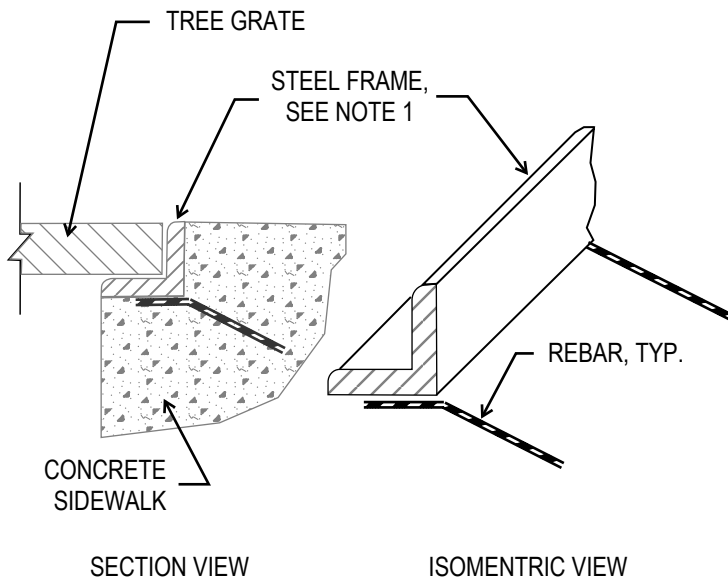

TREE GRATE FRAME AT CONCRETE SIDEWALK

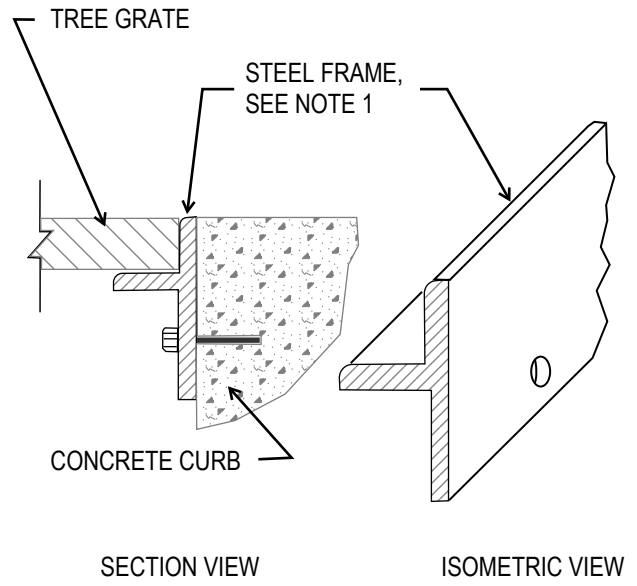

TREE GRATE FRAME AT CONCRETE CURB

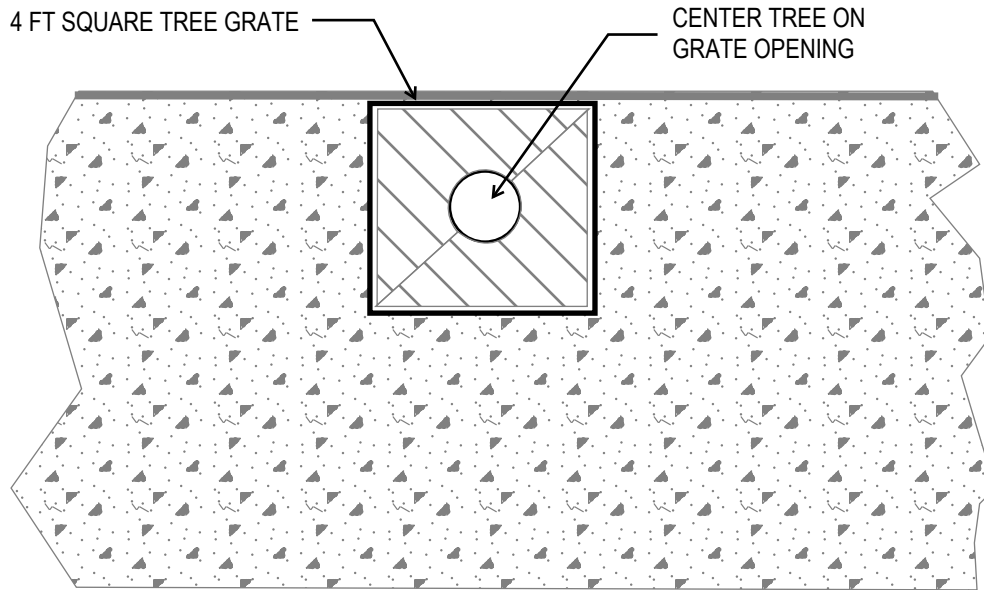

TREE GRATE TOP VIEW

NOTES:

1. ASSEMBLE AND INSTALL TREE GRATE PER MANUFACTURER'S RECOMMENDATION
2. TREE GRATE STYLE TO BE APPROVED BY CITY PRIOR TO INSTALLATION
3. TREE GRATES SHALL BE ADA COMPLIANT AND INSTALLED FLUSH WITH ADJACENT CONCRETE PER ADA GUIDELINES
- 4.. TREE GRATE MATERIAL SHALL BE CAST IRON
5. TREE GRATE OPENING SHALL BE 16 INCHES



CITY OF KENMORE

ENGINEERING DEPARTMENT
(425) 398-8900



TREE GRATE

FIGURE 6-008

NOT TO SCALE

Date: 12/31/2020

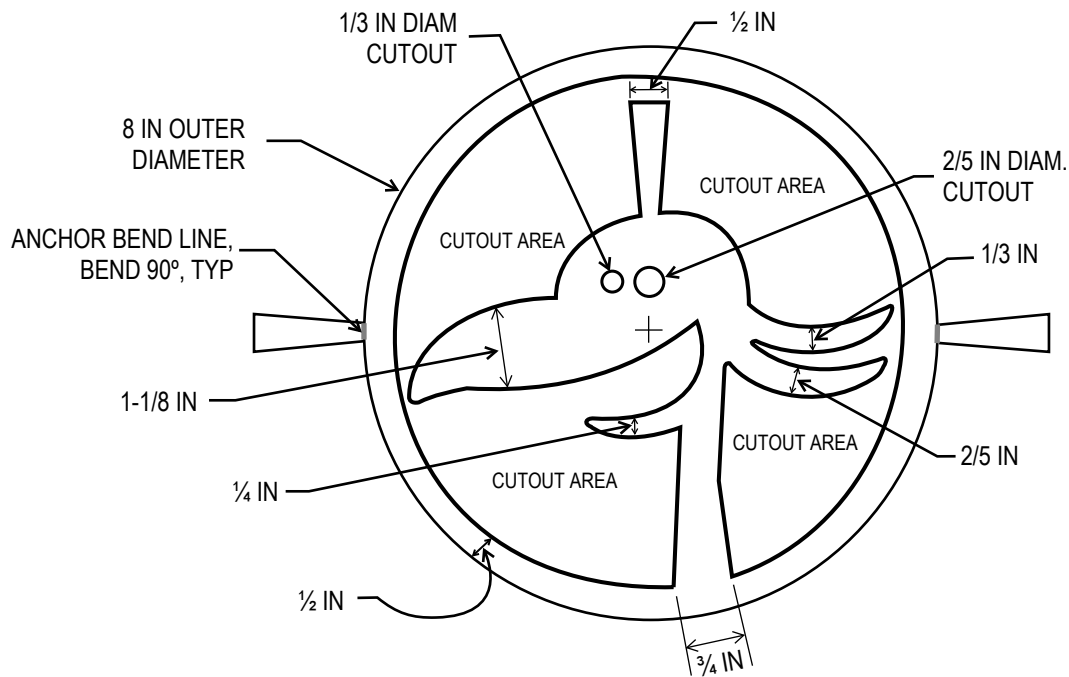

HANK PROFILE - TOP VIEW

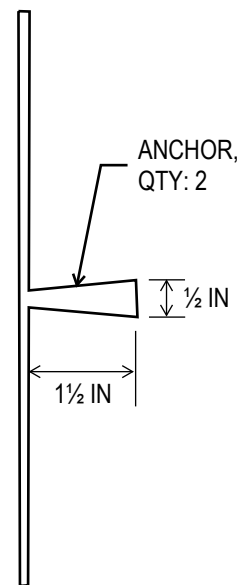

HANK PROFILE - SIDE VIEW

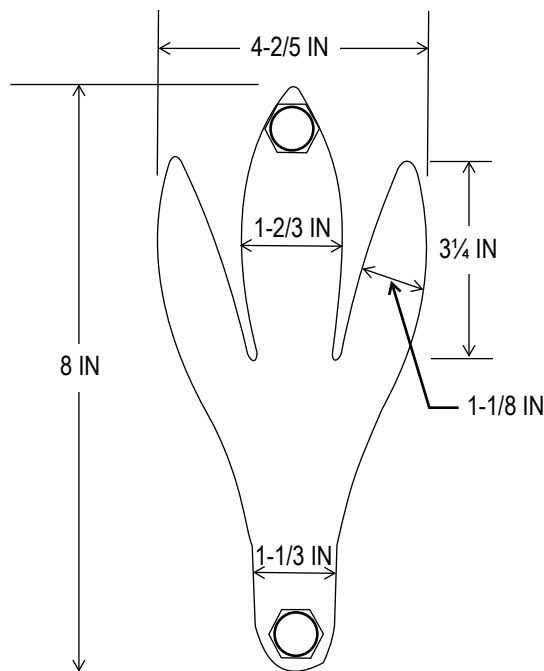

HANK FOOT - TOP VIEW

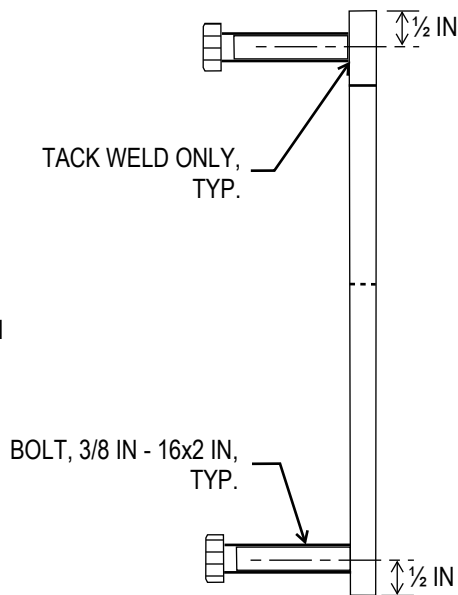

HANK FOOT - SIDE VIEW

NOTES:

1. MATERIALS SHALL BE 10 GAUGE STAINLESS STEEL
2. EDGES SHALL BE FILED TO REMOVE ALL SHARP EDGES AND ANY SPURS



CITY OF KENMORE

ENGINEERING DEPARTMENT
(425) 398-8900



HANK HERON

FIGURE 6-009

NOT TO SCALE

Date: 12/31/2020

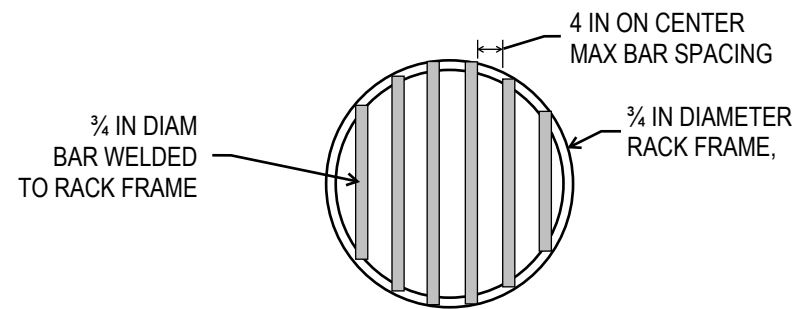
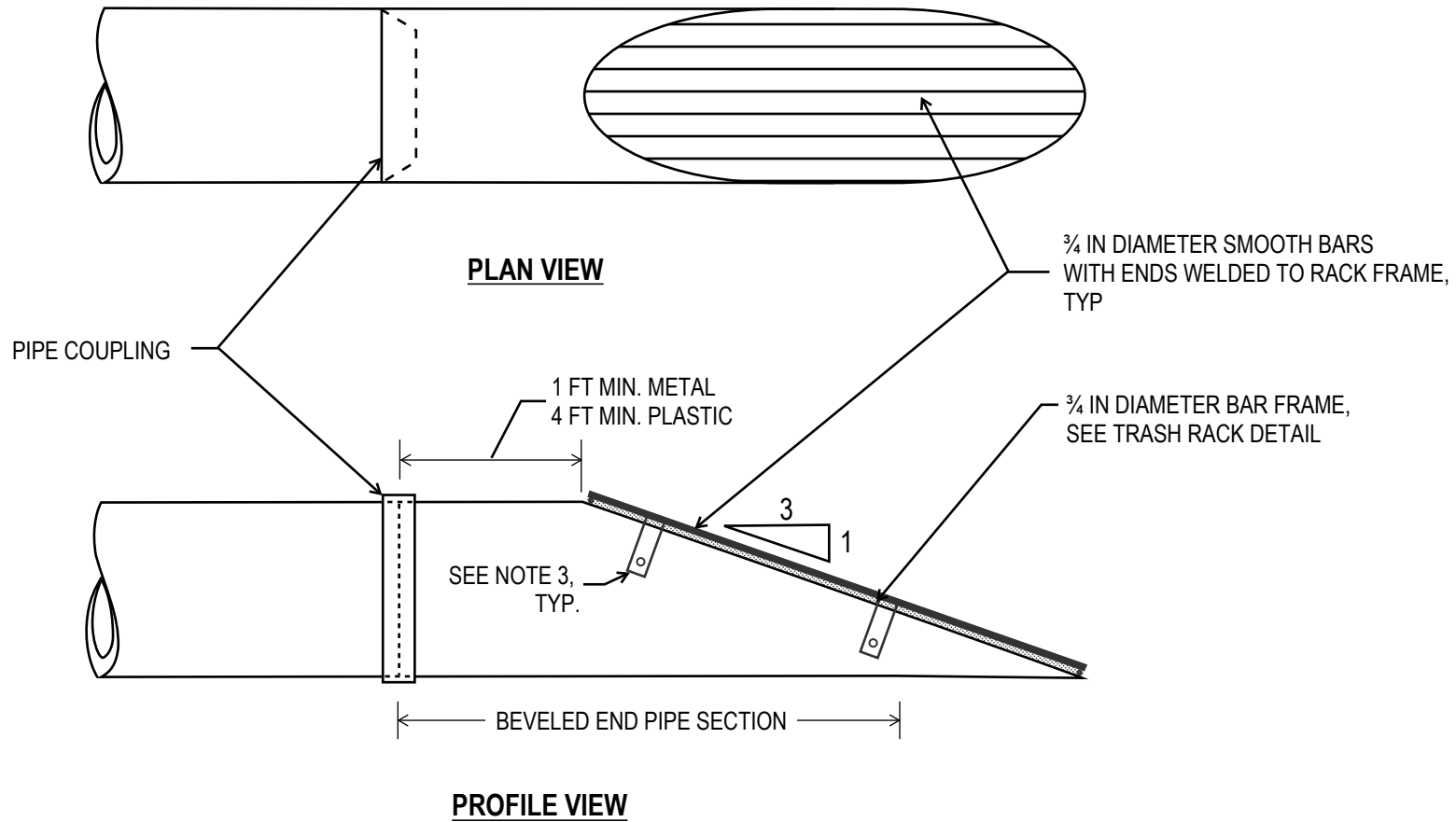

TRASH RACK DETAIL

NOTES:

1. SIDE SLOPE SHALL BE WARPED TO MATCH THE BEVELED PIPE END.
2. TRASH RACK REQUIRED ON ALL PIPES ENTERING A PIPED SYSTEM.
3. 2 IN x 5 IN ANCHOR STRIPS WELDED TO 3/4 IN. DIAMETER BAR FRAME 4 LOCATIONS SPACED UNIFORMLY. FASTEN WITH 1/2 IN BOLTS AND NUTS.
4. ALL TRASH RACK PARTS SHALL BE ALUMINIMUM OR GALVANIZED STEEL.
5. BEVELED END PIPE SECTION SHALL BE SAME MATERIAL AS CONNECTING PIPE.
6. FOR EXISTING CONCRETE PIPE, REPLACE ADJACENT CONCRETE PIPE WITH A CONCRETE PIPE WITH TONGUE END ON INLET SIDE AND INSTALL BEVELED END PIPE SECTION PER KCRS 7-001. SEAL JOINT WITH GROUT.



CITY OF KENMORE

ENGINEERING DEPARTMENT
(425) 398-8900



BEVELED END PIPE SECTION

FIGURE 7-001

NOT TO SCALE

Date: 01/05/2021

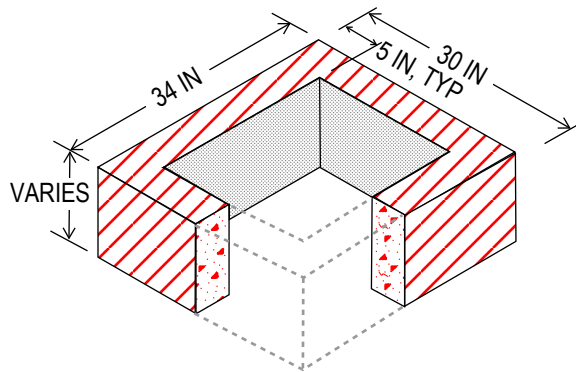

RISER ADJUSTMENT

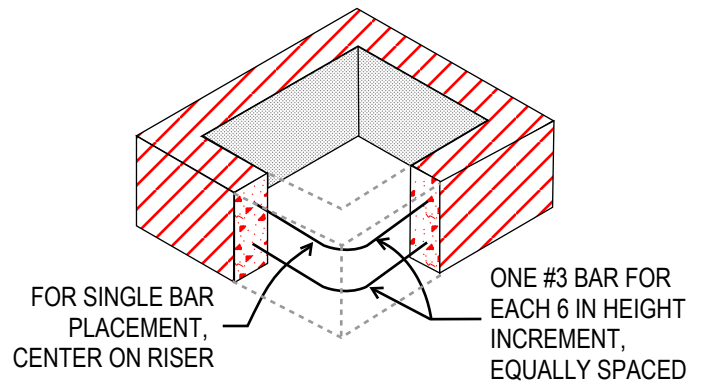

RISER REINFORCEMENT

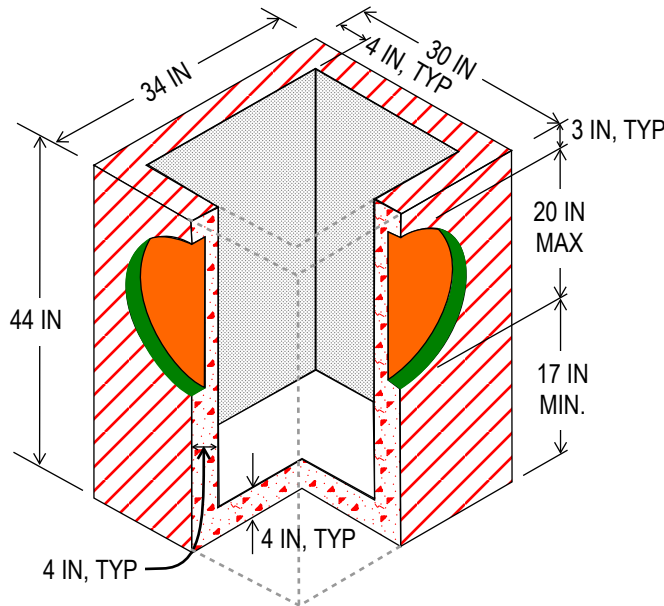

PRECAST BASE SECTION

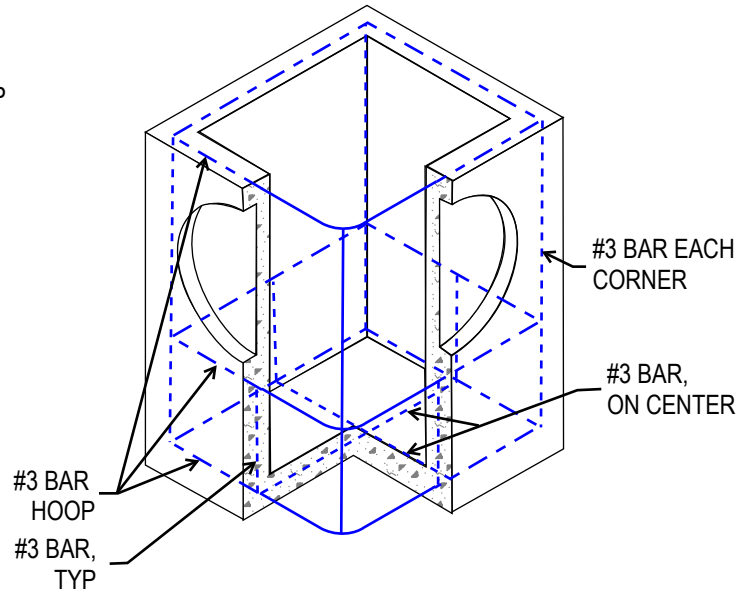

PRECAST BASE REINFORCEMENT

NOTES:

1. CATCH BASINS SHALL BE CONSTRUCTED IN ACCORDANCE WITH AASHTO M199 UNLESS OTHERWISE SHOWN ON THE PLANS OR NOTED IN THE WSDOT STANDARD SPECIFICATIONS.
2. AN ACCEPTABLE ALTERNATIVE TO REBAR WOULD BE WELDED WIRE FABRIC HAVING A MINIMUM AREA OF 0.12 SQ. IN. PER FT WELDED WIRE FABRIC SHALL COMPLY TO ASTM A497 (AASHTO M221). WIRE FABRIC SHALL NOT BE PLACED IN KNOCKOUTS.
3. ALL CATCH BASIN (RISER, FRAME, AND BASE SECTIONS) SHALL BE A MINIMUM OF 4000 PSI CONCRETE.
4. CATCH BASINS SHALL BE PROVIDED WITH FACTORY INSTALLED KNOCKOUTS ON EACH SIDE. KNOCKOUTS SHALL HAVE A WALL THICKNESS OF 2 IN MINIMUM TO 2½ IN MAXIMUM.
5. PIPES SHALL PASS THROUGH KNOCKOUT AREA ONLY.
6. GROUT FILL PICKUP HOLES, AROUND PIPE AND CATCH BASIN KNOCKOUTS, AND BETWEEN RISER SECTIONS AND FRAME PER WSDOT STANDARD SPECIFICATION 9-04.3.
7. THE TAPER ON THE SIDES OF THE BASE SECTION AND THE RISER SECTION SHALL NOT EXCEED ½ IN PER FT. EDGE OF RISERS SHALL NOT BE MORE THAN 2 IN FROM VERTICAL EDGE OF THE CATCH BASIN WALL.
8. METAL FRAME AND GRATE SHALL BE PER KSD 7-007 THROUGH 7-010.
9. BRICK RISERS MAY NOT BE USED UNLESS APPROVED BY THE CITY.
10. SHIMS MAY BE USED FOR MINOR ADJUSTMENTS. SHIMS SHALL BE HIGH IMPACT POLYSTYRENE WITH A MINIMUM COMPRESSIVE STRENGTH OF 8,000 PSI PER ASTM D695. RIMRISER® PRODUCTS MAY ALSO BE USED PER MANUFACTURER'S RECOMMENDATION FOR MINOR ADJUSTMENTS.

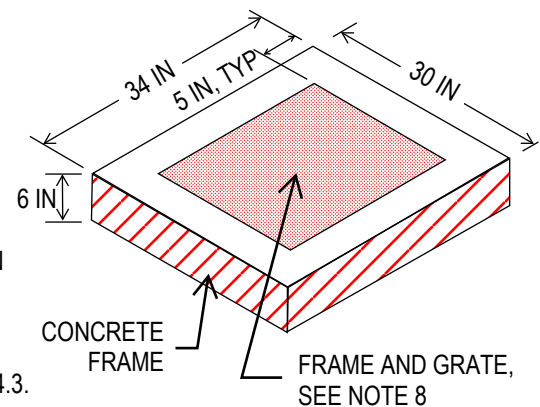

FRAME AND GRATE



CITY OF KENMORE

ENGINEERING DEPARTMENT
(425) 398-8900



**CATCH BASIN
TYPE 1**

FIGURE 7-003

NOT TO SCALE

Date: 05/25/2023

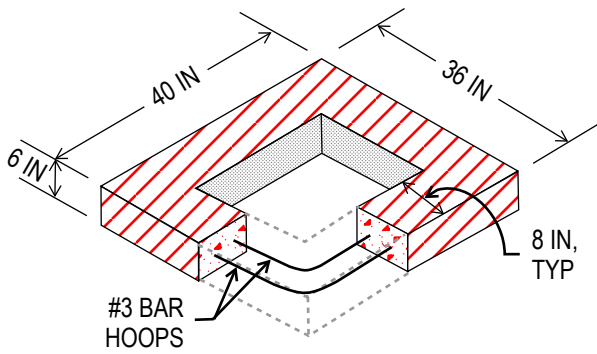

REDUCING SECTION AND REINFORCEMENT

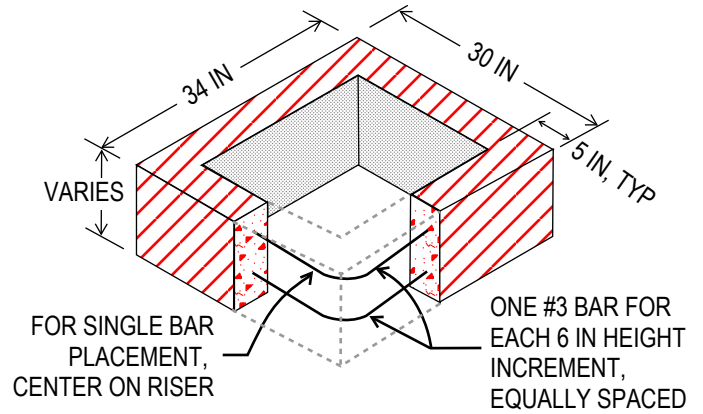

RISER ADJUSTMENT AND REINFORCEMENT

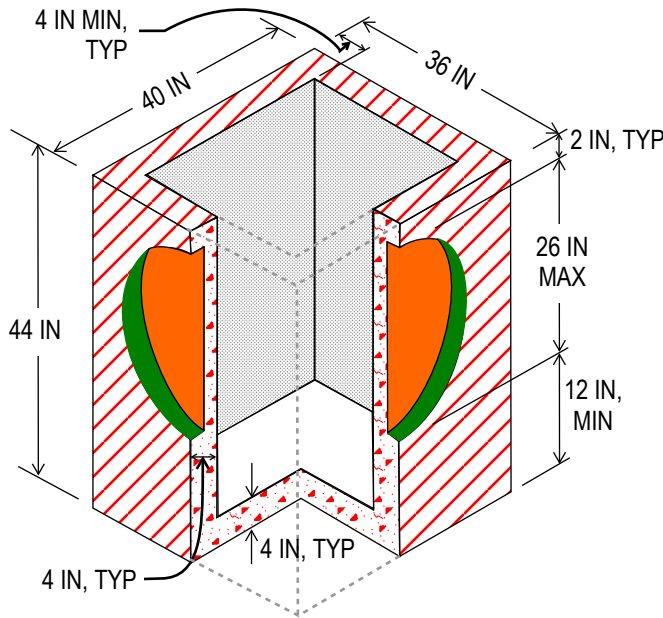

PRECAST BASE SECTION

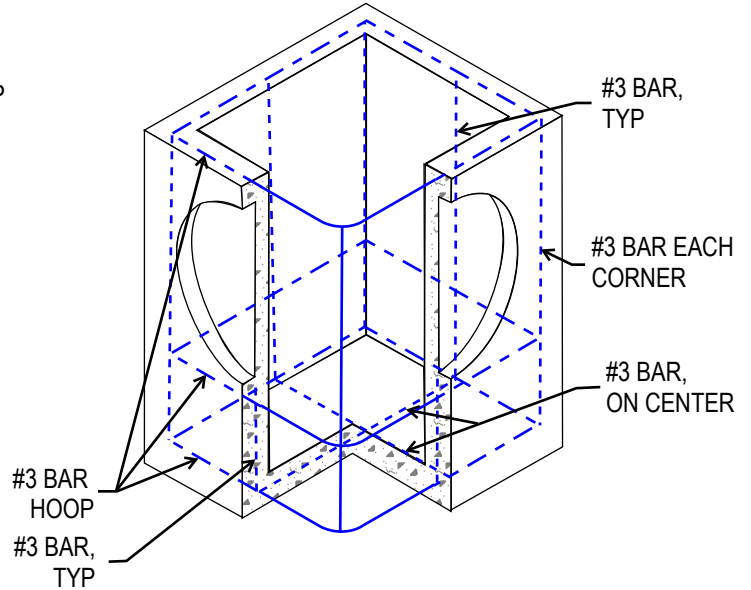

PRECAST BASE REINFORCEMENT

NOTES:

1. CATCH BASINS SHALL BE CONSTRUCTED IN ACCORDANCE WITH AASHTO M199 UNLESS OTHERWISE SHOWN ON THE PLANS OR NOTED IN THE WSDOT STANDARD SPECIFICATIONS.
2. AN ACCEPTABLE ALTERNATIVE TO REBAR WOULD BE WELDED WIRE FABRIC HAVING A MINIMUM AREA OF 0.12 SQ. IN. PER FT WELDED WIRE FABRIC SHALL COMPLY TO ASTM A497 (AASHTO M221). WIRE FABRIC SHALL NOT BE PLACED IN KNOCKOUTS.
3. ALL CATCH BASIN (RISER, FRAME, AND BASE SECTIONS) SHALL BE A MINIMUM OF 4000 PSI CONCRETE.
4. CATCH BASINS SHALL BE PROVIDED WITH FACTORY INSTALLED KNOCKOUTS ON EACH SIDE. KNOCKOUTS SHALL HAVE A WALL THICKNESS OF 2 IN MINIMUM TO 2½ IN MAXIMUM.
5. PIPES SHALL PASS THROUGH KNOCKOUT AREA ONLY.
6. GROUT FILL PICKUP HOLES, AROUND PIPE AND CATCH BASIN KNOCKOUTS, AND BETWEEN RISER SECTIONS AND FRAME PER WSDOT STANDARD SPECIFICATION 9-04.3.
7. THE TAPER ON THE SIDES OF THE BASE SECTION AND THE RISER SECTION SHALL NOT EXCEED ½ IN PER FT. EDGE OF RISERS SHALL NOT BE MORE THAN 2 IN FROM VERTICAL EDGE OF THE CATCH BASIN WALL.
8. METAL FRAME AND GRATE SHALL BE PER KSD 7-007 THROUGH 7-010.
9. BRICK RISERS MAY NOT BE USED UNLESS APPROVED BY THE CITY.
10. SHIMS MAY BE USED FOR MINOR ADJUSTMENTS. SHIMS SHALL BE HIGH IMPACT POLYSTYRENE WITH A MINIMUM COMPRESSIVE STRENGTH OF 8,000 PSI PER ASTM D695. RIMRISER® PRODUCTS MAY ALSO BE USED PER MANUFACTURER'S RECOMMENDATION FOR MINOR ADJUSTMENTS.

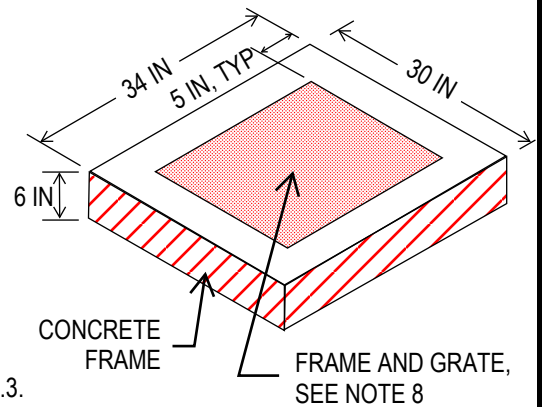

FRAME AND GRATE



CITY OF KENMORE

ENGINEERING DEPARTMENT
(425) 398-8900



**CATCH BASIN
TYPE 1L**

FIGURE 7-004

NOT TO SCALE

Date: 05/25/2023

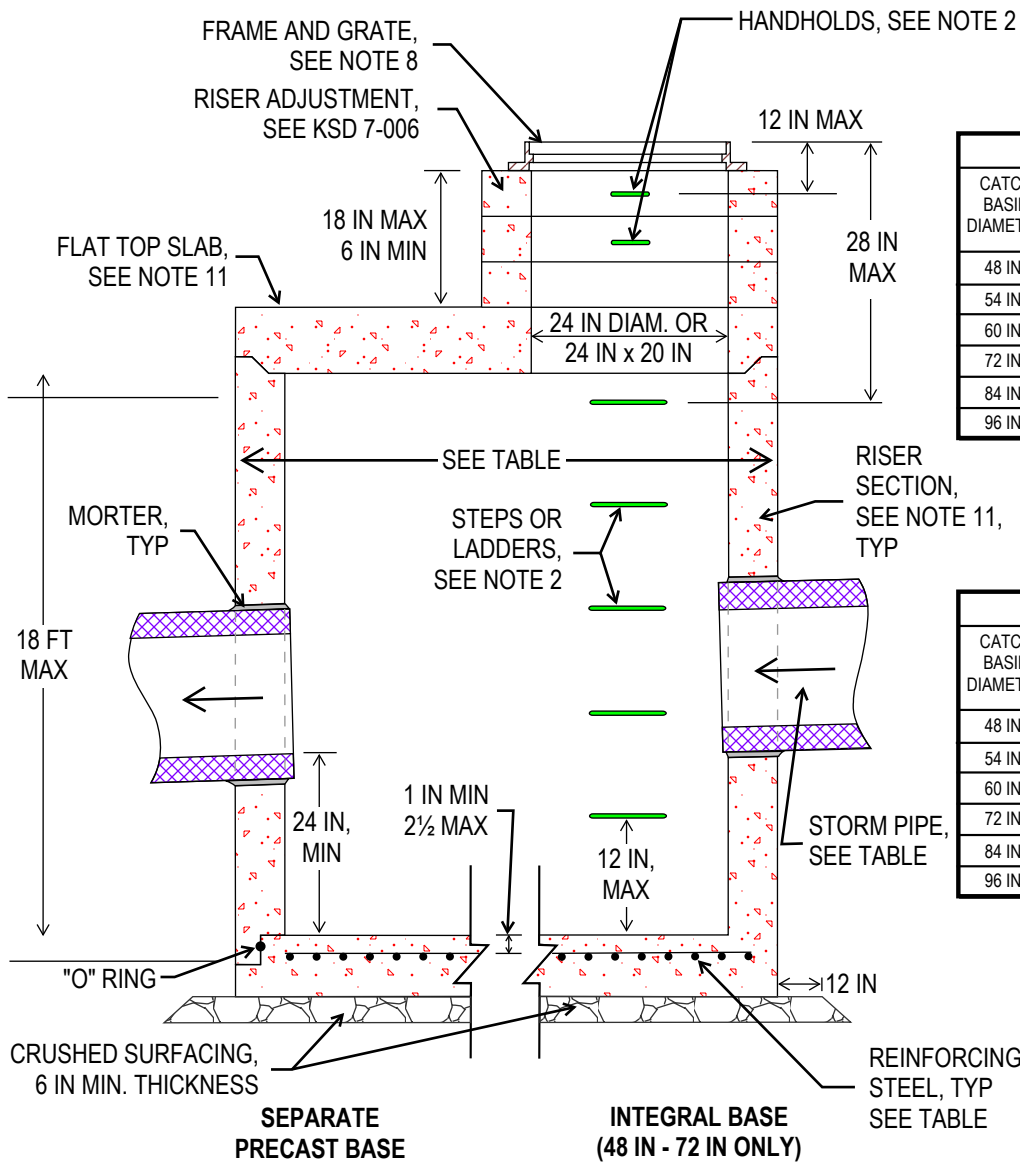

CATCH BASIN DIMENSIONS				
CATCH BASIN DIAMETER	MIN. WALL THICKNESS	MIN. BASE THICKNESS	MAX. SIZE KNOCKOUT	MIN. DISTANCE BETWEEN KNOCKOUTS
48 IN	4 IN	6 IN	36 IN	8 IN
54 IN	4½ IN	8 IN	42 IN	8 IN
60 IN	5 IN	8 IN	48 IN	8 IN
72 IN	6 IN	8 IN	60 IN	12 IN
84 IN	8 IN	12 IN	72 IN	12 IN
96 IN	8 IN	12 IN	84 IN	12 IN

CATCH BASIN DIMENSIONS				
CATCH BASIN DIAMETER	PIPE MATERIAL WITH MAX. INSIDE DIAMETER			
	CONCRETE PIPE	DUCTILE IRON PIPE	CPSS PIPE	SOLID WALL PVC PIPE
48 IN	24 IN	30 IN	24 IN	30 IN
54 IN	30 IN	36 IN	30 IN	36 IN
60 IN	36 IN	42 IN	36 IN	42 IN
72 IN	42 IN	54 IN	42 IN	54 IN
84 IN	54 IN	60 IN	54 IN	60 IN
96 IN	60 IN	72 IN	60 IN	72 IN

CPSS = CORRUGATED POLYETHYLENE STORM SEWER

MIN. BASE REINFORCEMENT		
CATCH BASIN DIAMETER	SEPARATE PRECAST BASE	INTEGRAL PRECAST BASE
48 IN	0.23 SQ IN/FT E.D.	0.15 SQ IN/FT E.D.
54 IN	0.19 SQ IN/FT E.D.	0.19 SQ IN/FT E.D.
60 IN	0.25 SQ IN/FT E.D.	0.25 SQ IN/FT E.D.
72 IN	0.35 SQ IN/FT E.D.	0.24 SQ IN/FT E.D.
84 IN	0.37 SQ IN/FT E.D.	0.27 SQ IN/FT E.D.
96 IN	0.39 SQ IN/FT E.D.	0.29 SQ IN/FT E.D.

E.D. = EACH DIRECTION

NOTES:

- CATCH BASINS SHALL BE CONSTRUCTED IN ACCORDANCE WITH AASHTO M199 UNLESS OTHERWISE SHOWN ON THE PLANS OR NOTED IN THE WSDOT STANDARD SPECIFICATIONS.
- STEPS/LADDERS AND HANDHOLDS PER KSD 7-006. ORIENTATE STEPS/LADDERS TO PROVIDE A MINIMUM OF 12 INCHES OF CLEARANCE FROM STORM PIPES.
- PIPES SHALL PASS THROUGH KNOCKOUT AREA ONLY.
- CATCH BASINS SHALL BE PROVIDED WITH A MINIMUM OF FOUR FACTORY INSTALLED KNOCKOUTS. KNOCKOUTS SHALL HAVE A WALL THICKNESS OF 2 IN MINIMUM TO 2½ IN MAXIMUM.
- ALL CATCH BASINS (RISER, RISER ADJUSTMENT, AND BASE SECTIONS) SHALL BE A MINIMUM OF 4000 PSI CONCRETE.
- GROUT FILL PICKUP HOLES AROUND PIPE AND CATCH BASIN KNOCKOUTS AND BETWEEN RISER SECTIONS AND FRAME PER WSDOT STANDARD SPECIFICATION 9-04.3.
- THE TAPER ON THE SIDES OF THE RISER/BASE SECTION AND THE RISER ADJUSTMENT SECTION SHALL NOT EXCEED ½ IN PER FT. EDGE OF NECK RISERS SHALL NOT BE MORE THAN 2 IN FROM VERTICAL EDGE OF THE CATCH BASIN WALL.
- METAL FRAME AND GRATE SHALL BE PER KSD 7-007 THROUGH 7-010.
- BRICK RISERS MAY NOT BE USED UNLESS APPROVED BY THE CITY.
- SHIMS MAY BE USED FOR MINOR ADJUSTMENTS. SHIMS SHALL BE HIGH IMPACT POLYSTYRENE WITH A MINIMUM COMPRESSIVE STRENGTH OF 8,000 PSI PER ASTM D695. RIMRISER® PRODUCTS MAY ALSO BE USED PER MANUFACTURER'S RECOMMENDATION FOR MINOR ADJUSTMENTS.
- RISER SECTION REINFORCEMENT SHALL BE PER MANUFACTURER'S RECOMMENDATION. SEE KSD 7-006 FOR REINFORCEMENT OF TOP SLAB AND RISER ADJUSTMENTS.
- RUBBER GASKETS SHALL BE USED AT JOINTS BETWEEN SECTIONS.



CITY OF KENMORE

ENGINEERING DEPARTMENT
(425) 398-8900



**CATCH BASIN
TYPE 2**

**FIGURE 7-005
NOT TO SCALE**

Date: 05/25/2023

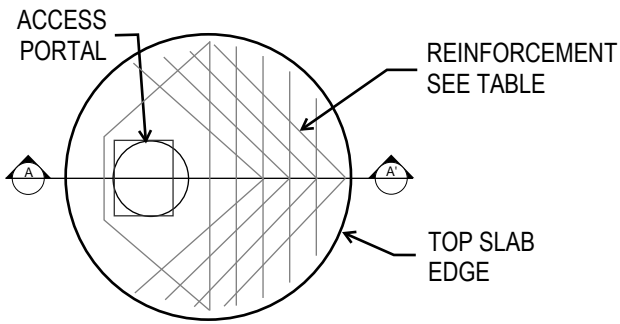

TOP SLAB PLAN VIEW

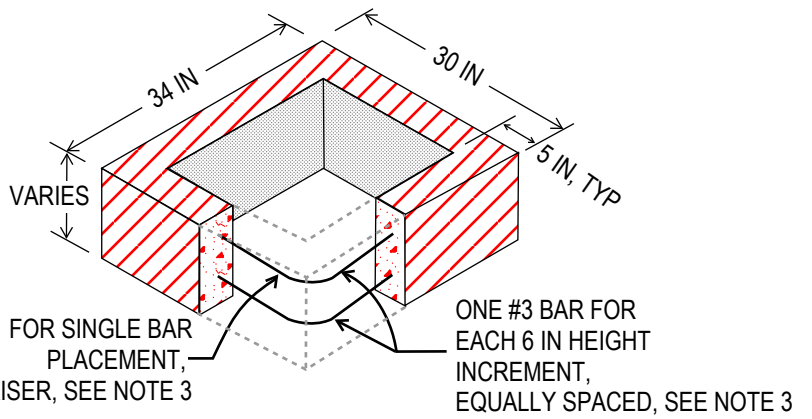

RISER ADJUSTMENT AND REINFORCEMENT

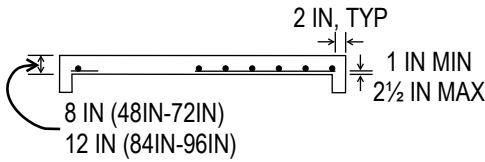

SECTION A-A'

TOP SLAB REINFORCEMENT		
CATCH BASIN DIAMETER	BAR SIZE	SPACING ON CENTER
48 IN	#4	6 IN
54 IN	#4	6 IN
60 IN	#4	6 IN
72 IN	#5	6 IN
84 IN	#6	7 IN
96 IN	#6	7 IN

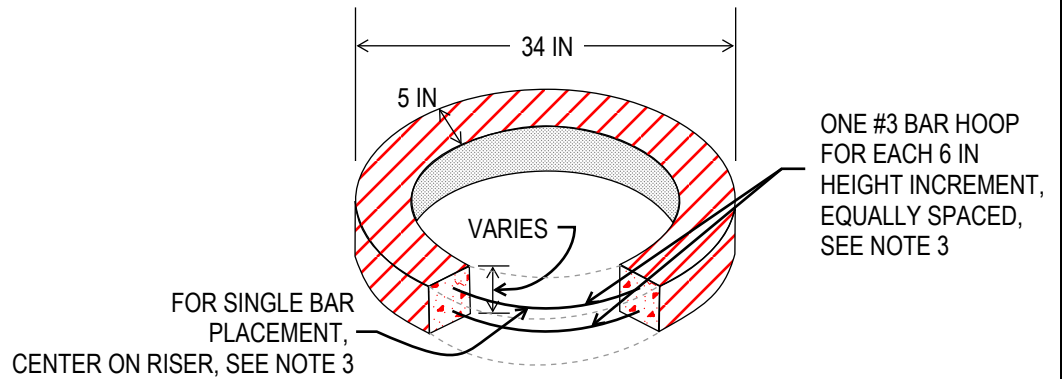

RISER ADJUSTMENT AND REINFORCEMENT

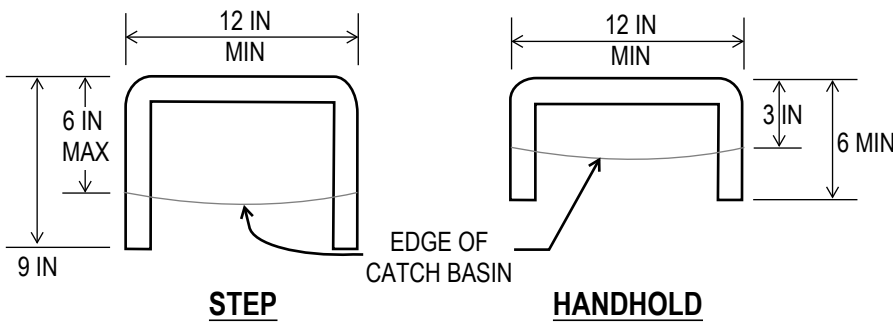

STEP

HANDHOLD

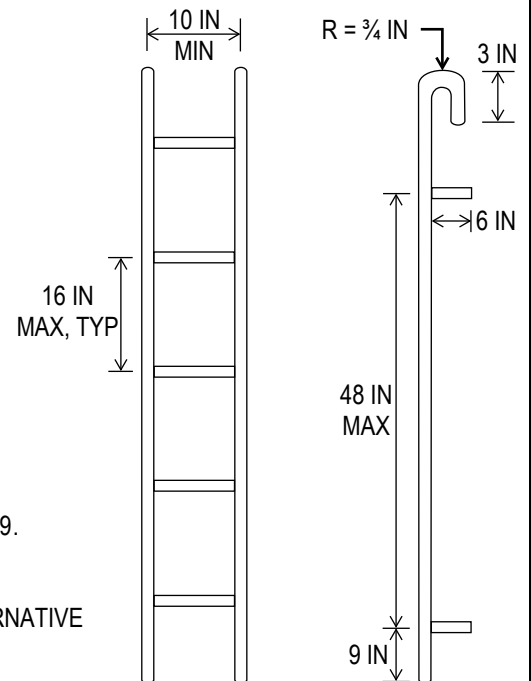

PREFABRICATED LADDER

NOTES:

1. STEPS, LADDERS, AND HANDHOLDS SHALL BE RELATIVELY PARALLEL TO THE CATCH BASIN WALL.
2. STEPS/LADDERS AND HANDHOLDS SHALL MEET THE REQUIREMENTS OF AASHTO M199.
3. AS AN ALTERNATIVE TO REBAR, WIRE MESH HAVING A MINIMUM AREA OF 0.12 SQ IN PER FOOT MAY BE USED FOR ADJUSTMENT RISERS. SYNTHETIC STRUCTURAL FIBERS MEETING PER WSDOT STANDARD 9-05.50(10) MAY ALSO BE USED AS AN ALTERNATIVE
4. HANGING LADDERS SHALL BE PERMANENTLY FASTENED AT TOP BY HANGING ON STEP OR BY BOLTING TO OR EMBEDDING IN CONCRETE WALL.
5. ALL STEPS AND HANDHOLDS SHALL BE #8 GALVANIZED DEFORMED REBAR OR COPOLYMER PROPYLENE.



CITY OF KENMORE

ENGINEERING DEPARTMENT
(425) 398-8900



**CATCH BASIN TYPE 2
MISC. DETAILS**

FIGURE 7-006

NOT TO SCALE

Date: 05/25/2023

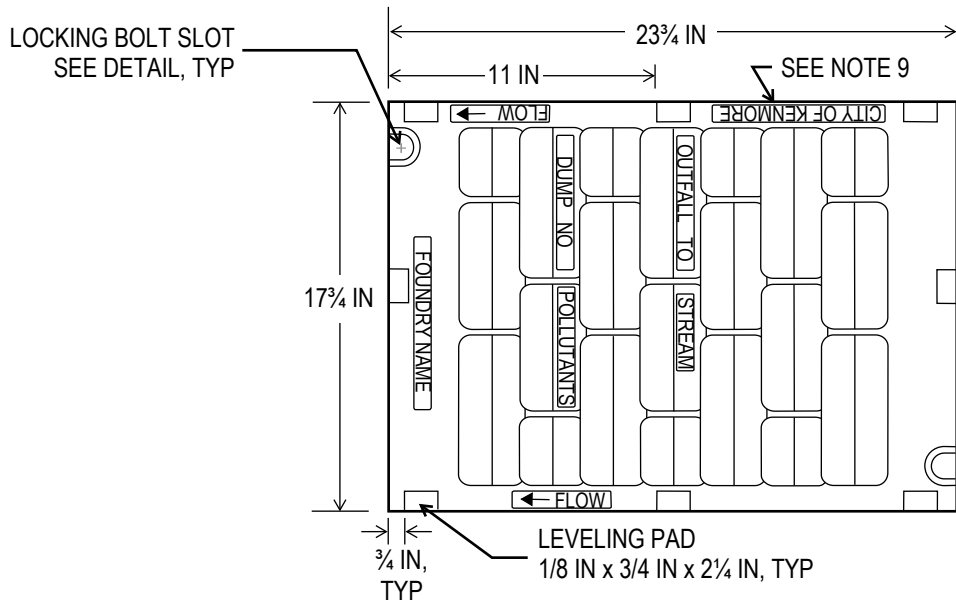

PLAN VIEW

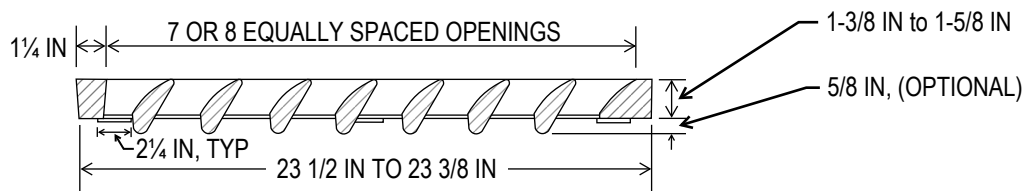

PROFILE VIEW

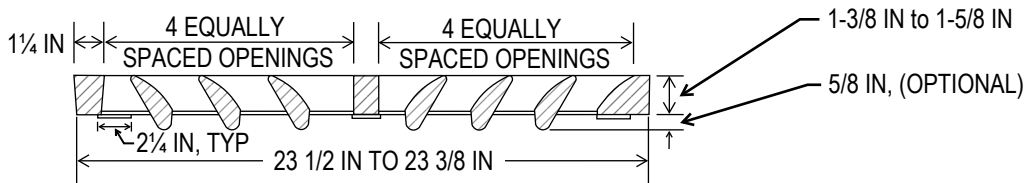

BI-DIRECTIONAL

NOTES:

1. USE MINIMUM OF (2) 5/8 IN - 11 NC STAINLESS STEEL TYPE 304 SOCKET HEAD (ALLEN HEAD) CAP SCREWS, 2 IN LONG.
2. GRATE SHALL BE GRADE 80-55-06 DUCTILE IRON MEETING THE REQUIREMENTS OF ASTM A536.
3. LOCATION OF LETTERING STAMPS ARE SHOWN FOR QUANTITY AND EXAMPLE. ACTUAL LOCATION OF EACH MAY VARY.
5. INSTALL A BI-DIRECTIONAL VANED GRATE AT LOCATIONS WHERE FLOW ENTERS THE BASIN FROM BOTH SIDES.
6. BOLT SLOT FORMED AND RECESSED FOR LOCKING BOLTS.
7. LETTERS ARE TO BE RECESSED SO FLUSH WITH SURROUNDING GRATE.
8. SEE WSDOT STANDARD SPECIFICATIONS SECTION 9-05.15 FOR METAL CASTING REQUIREMENTS.
9. FOR CATCH BASINS ON PRIVATE PROPERTY, OWNED AND OPERATED, REPLACE "CITY OF KENMORE" WITH "PRIVATE".

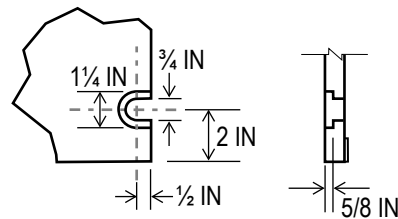

LOCKING BOLT DETAIL



CITY OF KENMORE

ENGINEERING DEPARTMENT
(425) 398-8900



VANED GRATE

FIGURE 7-007

NOT TO SCALE

Date: 07/25/2021

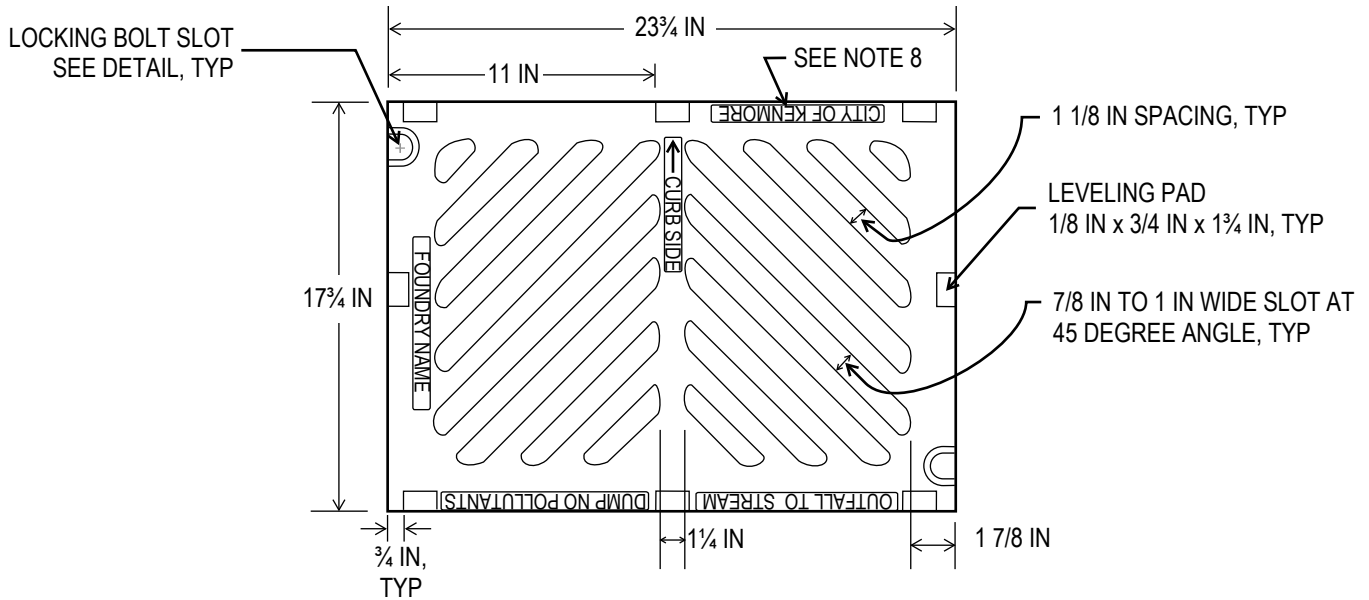

PLAN VIEW

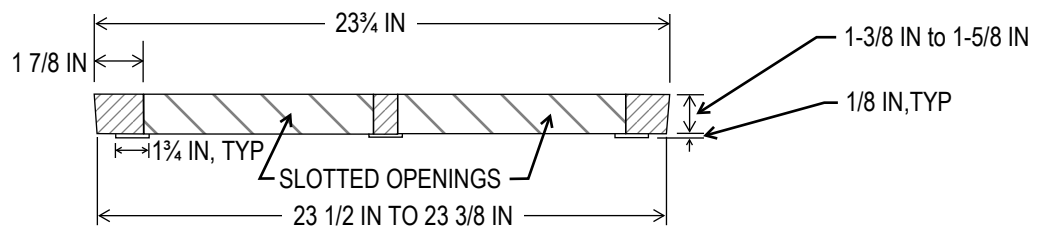

PROFILE VIEW

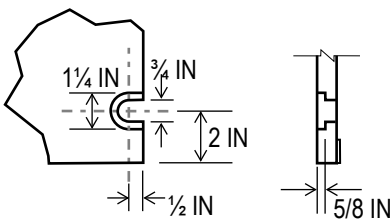

LOCKING BOLT DETAIL

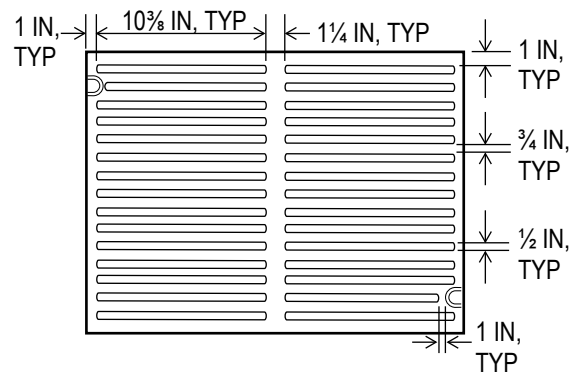

ADA GRATE, PLAN VIEW

SEE NOTE 9

NOTES:

1. USE MINIMUM OF (2) 5/8 IN - 11 NC STAINLESS STEEL TYPE 304 SOCKET HEAD (ALLEN HEAD) CAP SCREWS, 2 IN LONG.
2. GRATE SHALL BE GRADE 80-55-06 DUCTILE IRON MEETING THE REQUIREMENTS OF ASTM A536.
3. LOCATION OF LETTERING STAMPS ARE SHOWN FOR QUANTITY AND EXAMPLE. ACTUAL LOCATION OF EACH MAY VARY.
4. SEE KSD 7-010 FOR FRAME REQUIREMENTS AND INSTALLATION
5. BOLT SLOT FORMED AND RECESSED FOR LOCKING BOLTS.
6. LETTERS ARE TO BE RECESSED SO FLUSH WITH SURROUNDING GRATE.
7. SEE WSDOT STANDARD SPECIFICATIONS SECTION 9-05.15 FOR METAL CASTING REQUIREMENTS.
8. FOR CATCH BASINS ON PRIVATE PROPERTY, OWNED AND OPERATED, REPLACE "CITY OF KENMORE" WITH "PRIVATE".
9. FOR CATCH BASINS WITHIN THE PEDESTRIAN ROUTE WHERE STORM WATER CAPTURE IS NECESSARY



CITY OF KENMORE

ENGINEERING DEPARTMENT
(425) 398-8900



**DIAGONAL SLOTTED
GRATE**

FIGURE 7-008

NOT TO SCALE

Date: 05/25/2023

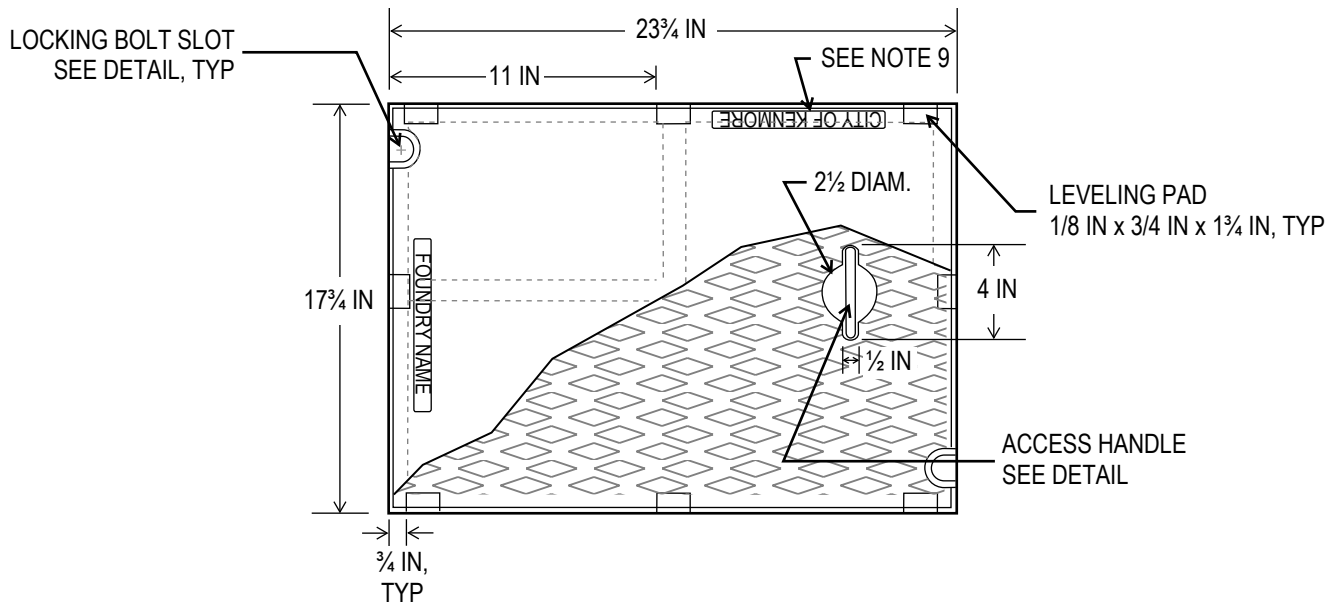

PLAN VIEW

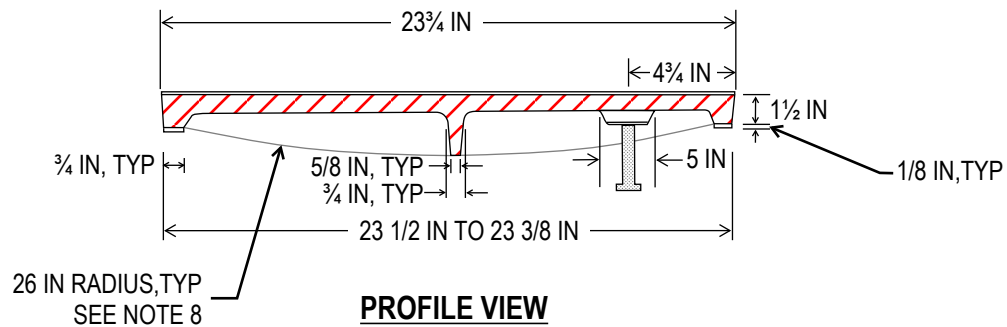

PROFILE VIEW

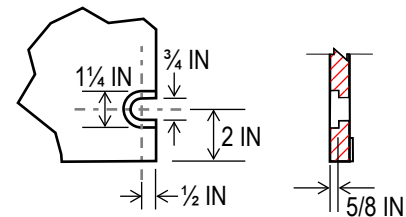

LOCKING BOLT DETAIL

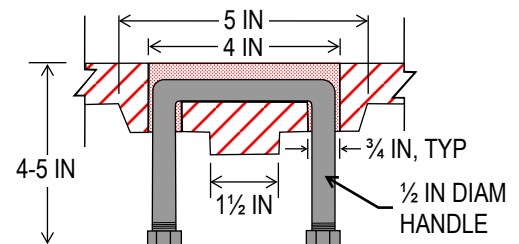

ACCESS HANDLE DETAIL

NOTES:

1. USE MINIMUM OF (2) 5/8 IN - 11 NC STAINLESS STEEL TYPE 304 SOCKET HEAD (ALLEN HEAD) CAP SCREWS, 2 IN LONG.
2. GRATE SHALL BE GRADE 80-55-06 DUCTILE IRON MEETING THE REQUIREMENTS OF ASTM A536.
3. LOCATION OF LETTERING STAMPS ARE SHOWN FOR QUANTITY AND EXAMPLE. ACTUAL LOCATION OF EACH MAY VARY.
4. SEE KSD 7-010 FOR FRAME REQUIREMENTS AND INSTALLATION
5. BOLT SLOT FORMED AND RECESSED FOR LOCKING BOLTS.
6. LETTERS ARE TO BE RECESSED SO FLUSH WITH SURROUNDING GRATE.
7. SEE WSDOT STANDARD SPECIFICATIONS SECTION 9-05.15 FOR METAL CASTING REQUIREMENTS.
8. ALTERNATIVE REINFORCING DESIGNS ARE ACCEPTABLE IN LIEU OF THE RIB DESIGN SHOWN.
9. FOR CATCH BASINS ON PRIVATE PROPERTY, OWNED AND OPERATED, REPLACE "CITY OF KENMORE" WITH "PRIVATE".



CITY OF KENMORE

ENGINEERING DEPARTMENT
(425) 398-8900



SOLID COVER

FIGURE 7-009

NOT TO SCALE

Date: 01/25/2021

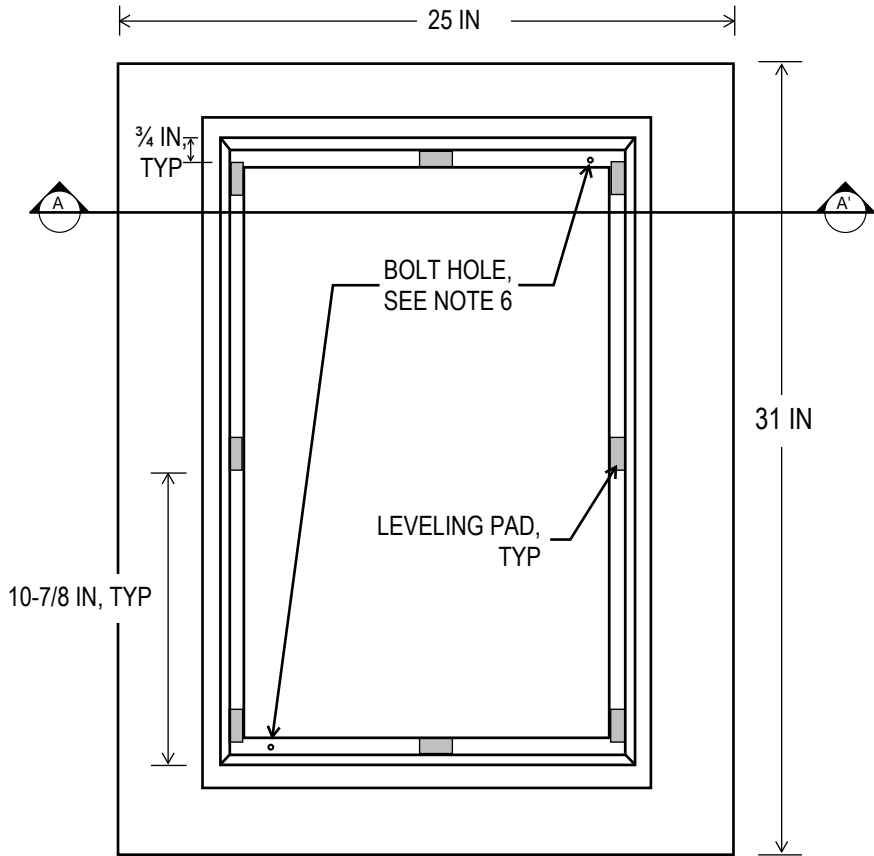

FRAME PLAN VIEW

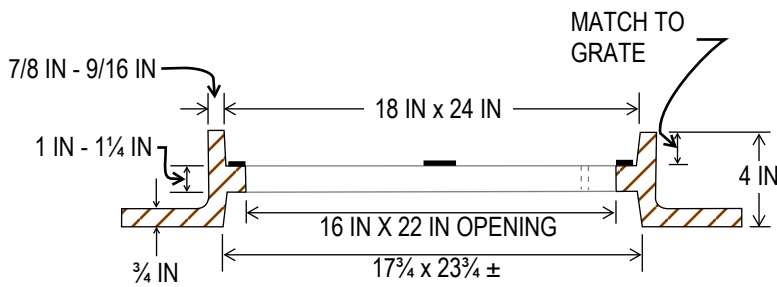

SECTION A-A'

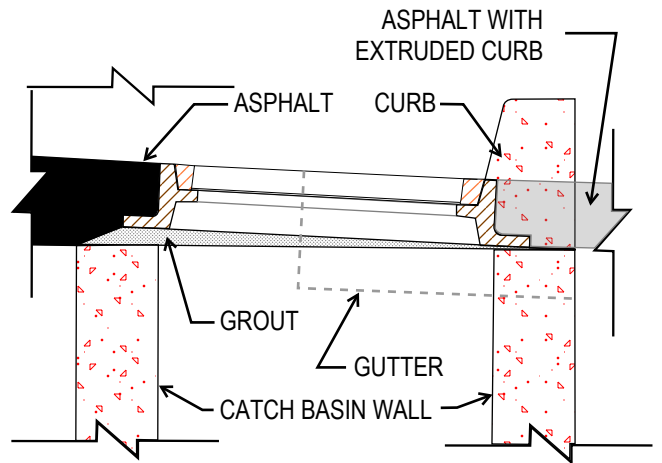

INSTALLATION

NOTES:

1. SEE KSD 7-007, 7-008, AND 7-009 FOR GRATE REQUIREMENTS.
2. FRAME SHALL BE CLASS 30 DUCTILE IRON MEETING THE REQUIREMENTS OF ASTM A48.
3. SET FRAME FLUSH WITH ADJACENT ASPHALT PAVEMENT.
4. GRATE TO BE FLUSH WITH FRAME.
5. SEE WSDOT STANDARD SPECIFICATIONS SECTION 9-05.15 FOR METAL CASTING REQUIREMENTS.
6. DRILL AND TAP LOCKING BOLT.
7. FRAMES TO BE INSTALLED UPSTREAM AND OUT OF CURB RAMP .



CITY OF KENMORE

ENGINEERING DEPARTMENT
(425) 398-8900



SQUARE FRAME

FIGURE 7-010

NOT TO SCALE

Date: 01/25/2021

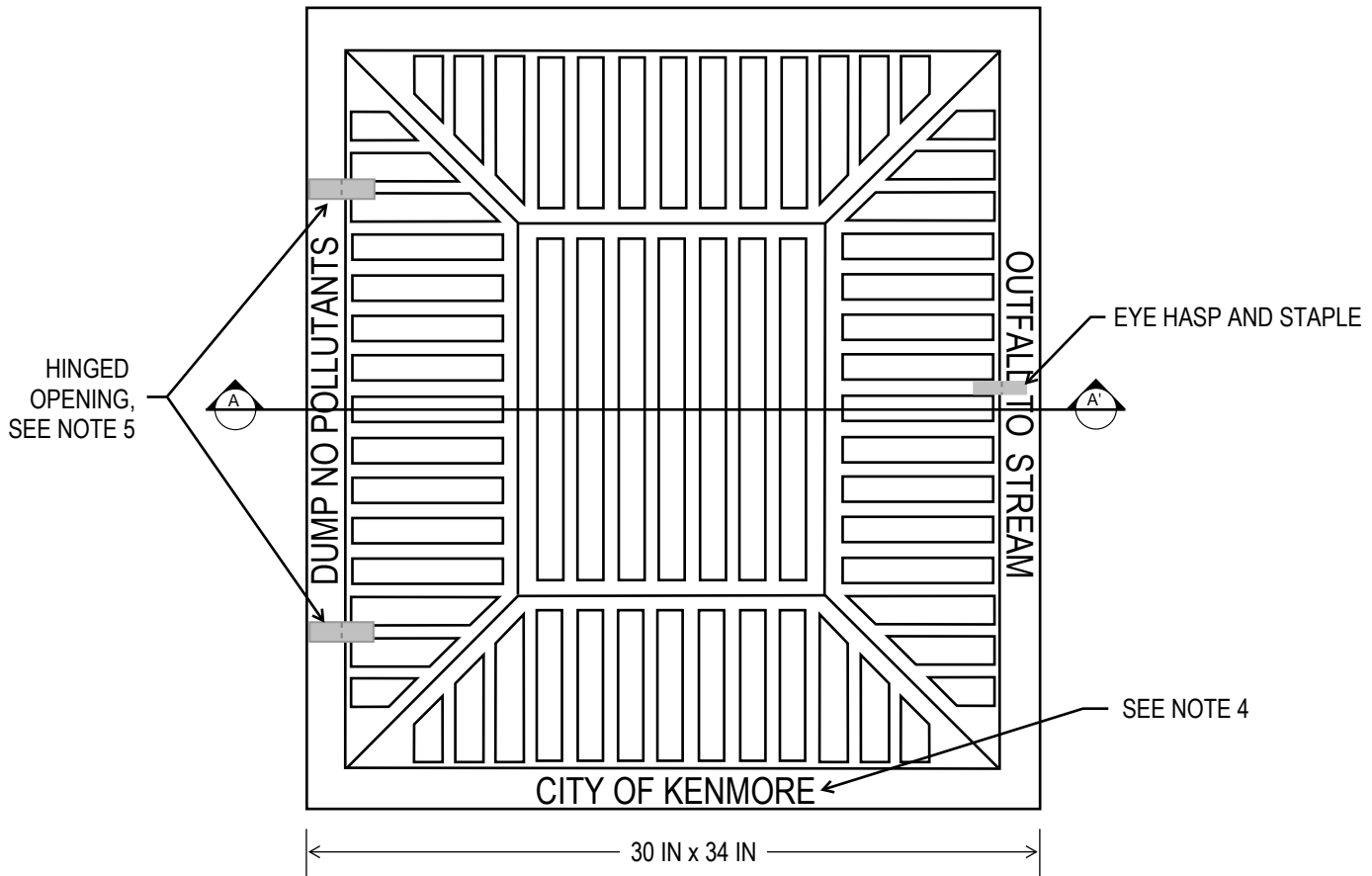

TOP VIEW

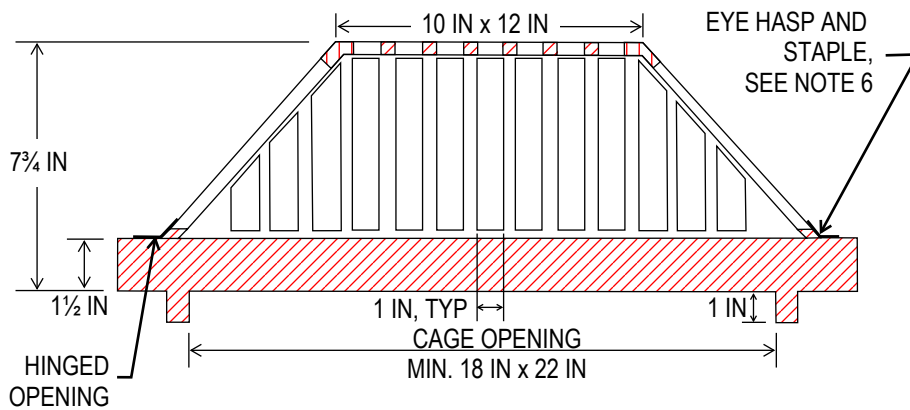

CROSS SECTION A-A'

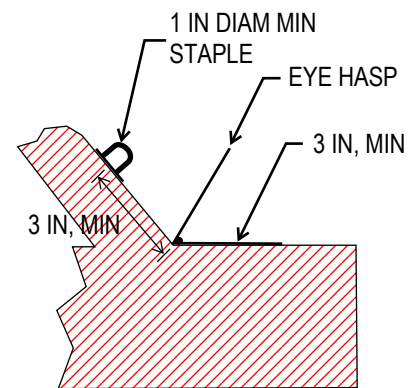

STAPLE AND HASP

NOTES:

1. ALL STEEL IN PLATES, BARS AND BANDS SHALL CONFORM TO THE REQUIREMENTS OF ASTM A38
2. DEBRIS CAGE AND FRAME SHALL BE HOT-DIP GALVANIZED IN ACCORDANCE WITH ASTM A123 (AASHTO M111)
3. DIMENSIONS FOR FRAME SHALL PROVIDE A SNUG FIT WITHIN PROPOSED CATCH BASIN
4. FOR CATCH BASINS ON PRIVATE PROPERTY, OWNED AND OPERATED, REPLACE "CITY OF KENMORE" WITH "PRIVATE".
5. 2 IN x 5 IN ANCHOR HINGED STRIPS WELDED TO LONG SIDE OF CAGE AND FRAME LOCATIONS SPACED UNIFORMLY.
6. 1 1/2 IN WIDE EYE HASP WITH STAPLE WELDED TO FRAME AND CAGE.



CITY OF KENMORE

ENGINEERING DEPARTMENT
(425) 398-8900



**DEBRIS CAGE FOR
CATCH BASIN**

FIGURE 7-011

NOT TO SCALE

Date: 02/04/2021

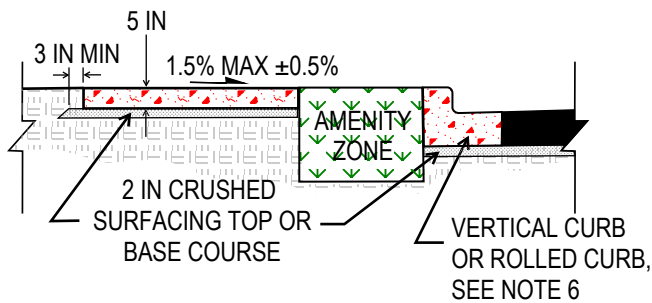
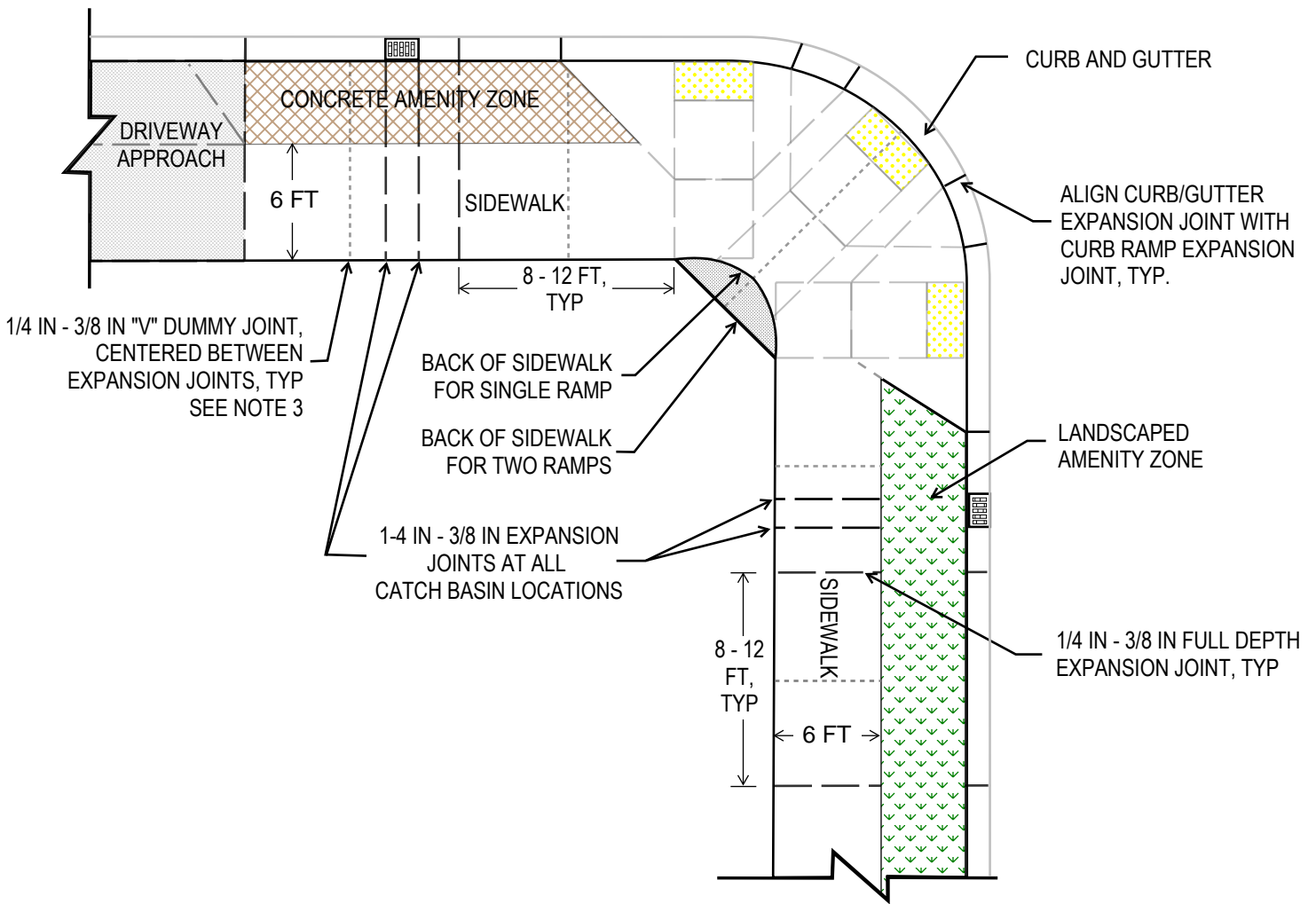

SIDEWALK WITH LANDSCAPED AMENITY ZONE

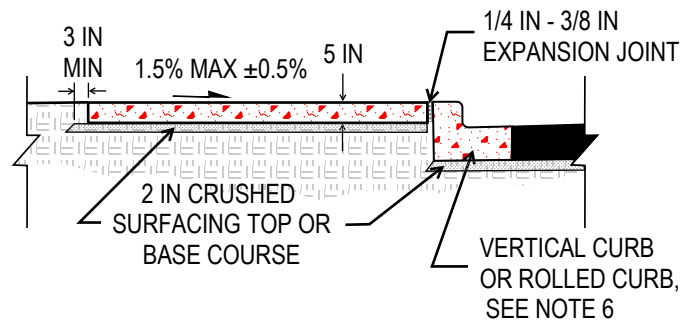

SIDEWALK WITH CONCRETE AMENITY ZONE

NOTES:

1. SPACE DUMMY AND EXPANSION JOINTS AS NOTED, FULL WIDTH OF SIDEWALK.
2. EXPANSION JOINTS SHALL BE EQUALLY SPACED AND FLUSH WITH ADJACENT SIDEWALK PANELS.
3. SEE KSD 8-008 FOR ADDITIONAL CONCRETE PLACEMENT AND FINISHING REQUIREMENTS.
4. EXPANSION JOINTS IN CURB/GUTTER TO ALIGN WITH EXPANSION JOINTS IN SIDEWALK.
5. BACKFILL MATERIAL PER WSDOT STANDARD SPECIFICATION SECTION 9-03.
6. SEE KSD 8-009 FOR CURB REQUIREMENTS.
7. JOINTING AROUND DRIVEWAY APPROACH AND CURB RAMPS FOR REFERENCE ONLY, SEE RESPECTIVE KSD FOR SPECIFIC REQUIREMENTS FOR EACH TYPE.
8. CURB RAMPS SHOWN FOR REFERENCE ONLY. ACTUAL LOCATION, TYPE AND QUANTITY TO BE APPROVED BY THE CITY AND WILL VARY DEPENDING UPON SITE CONDITIONS.
9. FOR REPLACEMENT SIDEWALK, EXISTING SIDEWALK SHALL BE REMOVED FROM JOINT TO JOINT, NO SAWCUTTING PERMITTED.



CITY OF KENMORE

ENGINEERING DEPARTMENT
(425) 398-8900



SIDEWALK

FIGURE 8-001

NOT TO SCALE

Date: 05/25/2023

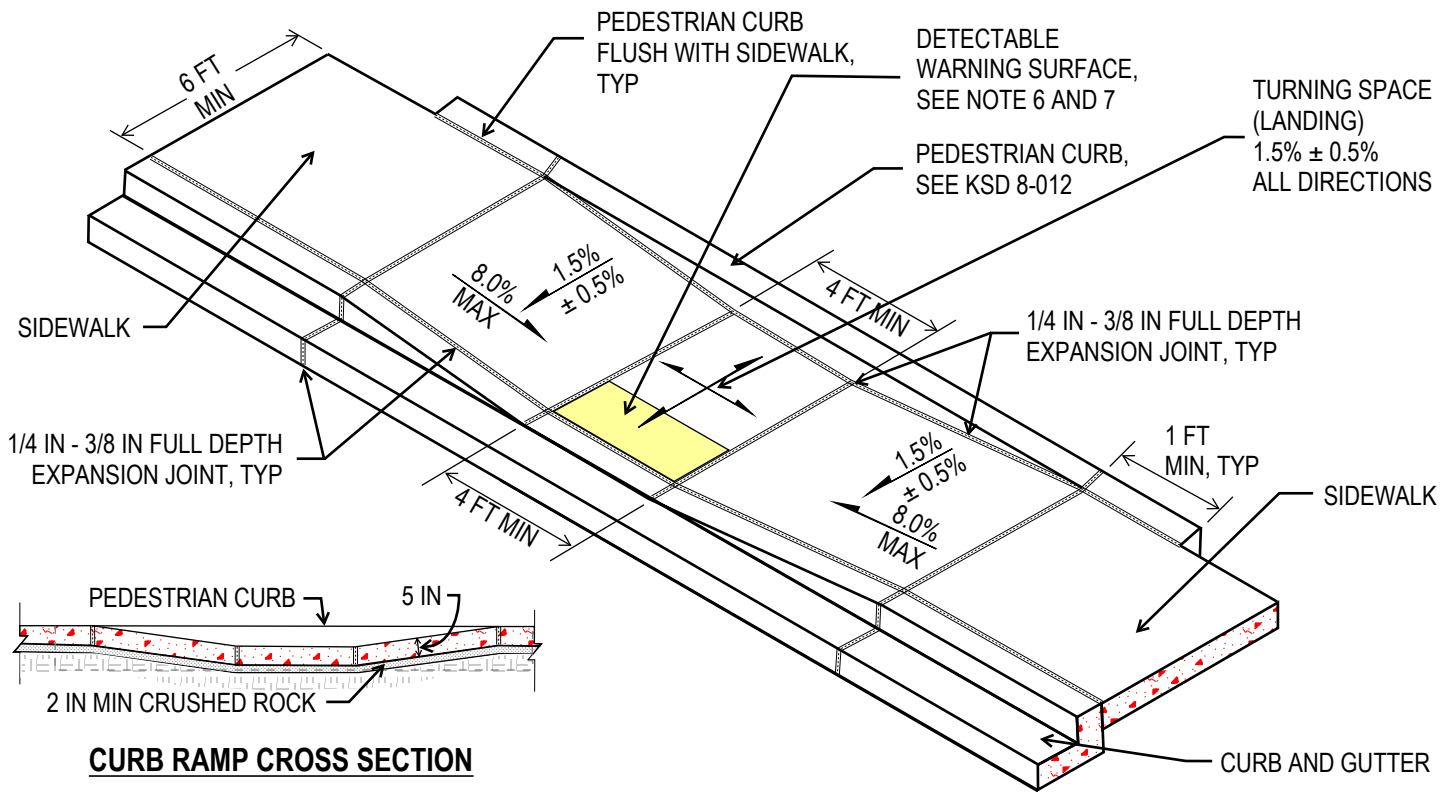

CURB RAMP CROSS SECTION

PLAN VIEW

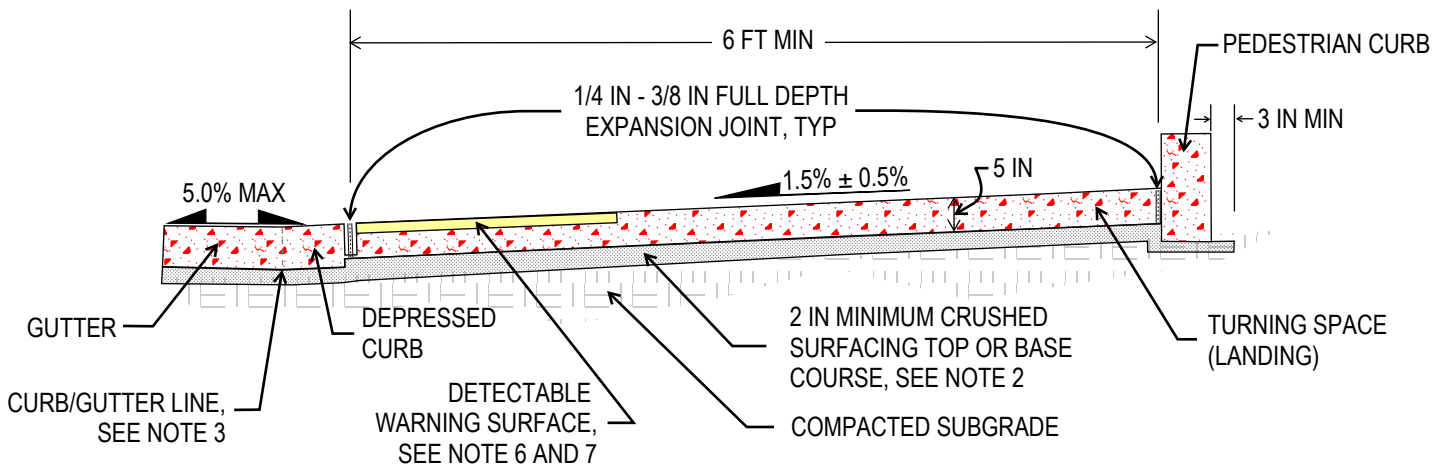

TURNING SPACE CROSS SECTION

- NOTES:
1. ALLOWABLE SLOPES AND WIDTHS ARE SHOWN. VARIATIONS FROM THE ABOVE STANDARDS MAY BE APPROVED AT THE DISCRETION OF THE CITY ENGINEER. RAMP MAY EXCEED 8.33% IF THE LENGTH IS A MINIMUM OF 15 FT.
 2. BACKFILL MATERIAL PER WSDOT STANDARD SPECIFICATION SECTION 9-03.
 3. DEPRESSED CURB MUST BE FLUSH WITH ADJACENT GUTTER AND CURB RAMP $\pm 1/8$ IN.
 4. ALL CONCRETE PANELS SHALL BE FLUSH WITH ADJACENT CONCRETE PANELS WITH NO GREATER THAN 1/8 IN VERTICAL DIFFERENCE.
 5. SEE KSD 4-001 FOR ADDITIONAL CURB RAMP PLACEMENT REQUIREMENTS.
 6. DETECTABLE WARNING SURFACE (DWS) SHALL BE FLUSH WITH SURROUNDING RAMP AND DEPRESSED CURB $\pm 1/8$ IN. DWS AND GRADE BREAKS SHALL BE PERPENDICULAR TO DIRECTION OF PEDESTRIAN TRAVEL. DWS SHALL BE WITHIN 5 FEET OF CURB.
 7. DWS SHALL BE COMPLIANT WITH ADA GUIDELINES AND BE COMPOSED OF POLYMER MATERIAL ONLY. COLOR SHALL BE YELLOW MATCHING FEDERAL STANDARD 595 COLOR NUMBER 33538. COLOR SHALL BE THROUGHOUT (SURFACE COATINGS ONLY NOT ALLOWED). DWS SHALL BE CAST IN PLACE, SURFACE MOUNT DWS ARE NOT ALLOWED.
 8. CATCH BASINS AND INLETS SHALL BE INSTALLED A MINIMUM OF 1 FOOT UPSTREAM FROM THE BASE OF ANY CURB RAMP.
 9. RAMP AND TURNING SPACE SHALL NOT HAVE ANY EXPANSION JOINTS EXCEPT ALONG BORDERS.
 10. FOR EXISTING SIDEWALK/RAMP LOCATIONS, CONCRETE SHALL BE REMOVED FROM JOINT TO JOINT; NO SAWCUTTING IS PERMITTED.



CITY OF KENMORE

ENGINEERING DEPARTMENT
(425) 398-8900



PARALLEL CURB RAMP

FIGURE 8-003

NOT TO SCALE

Date: 06/21/2022

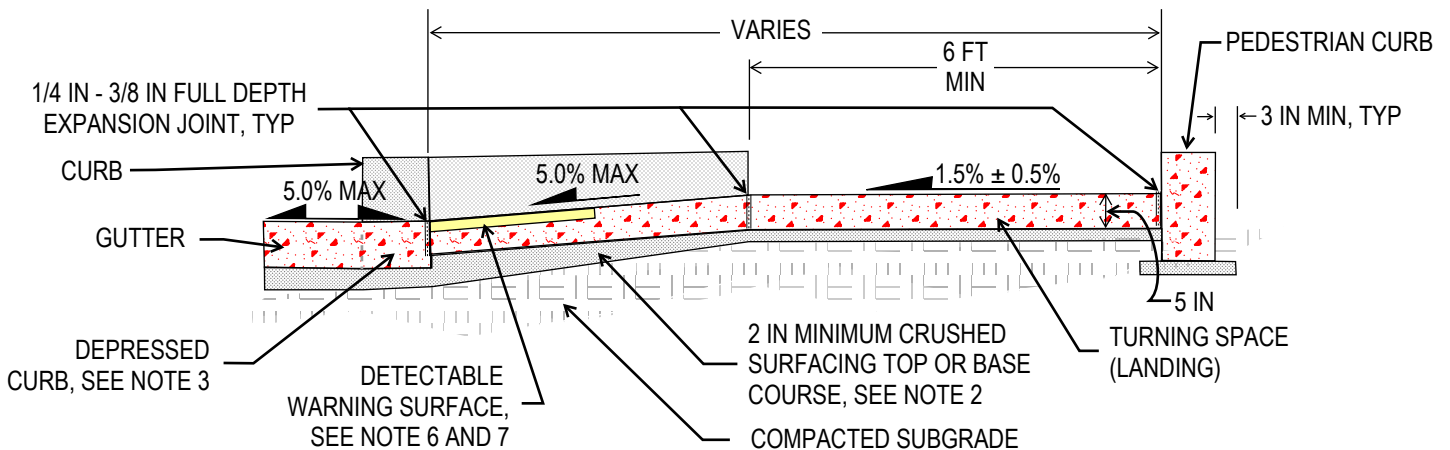
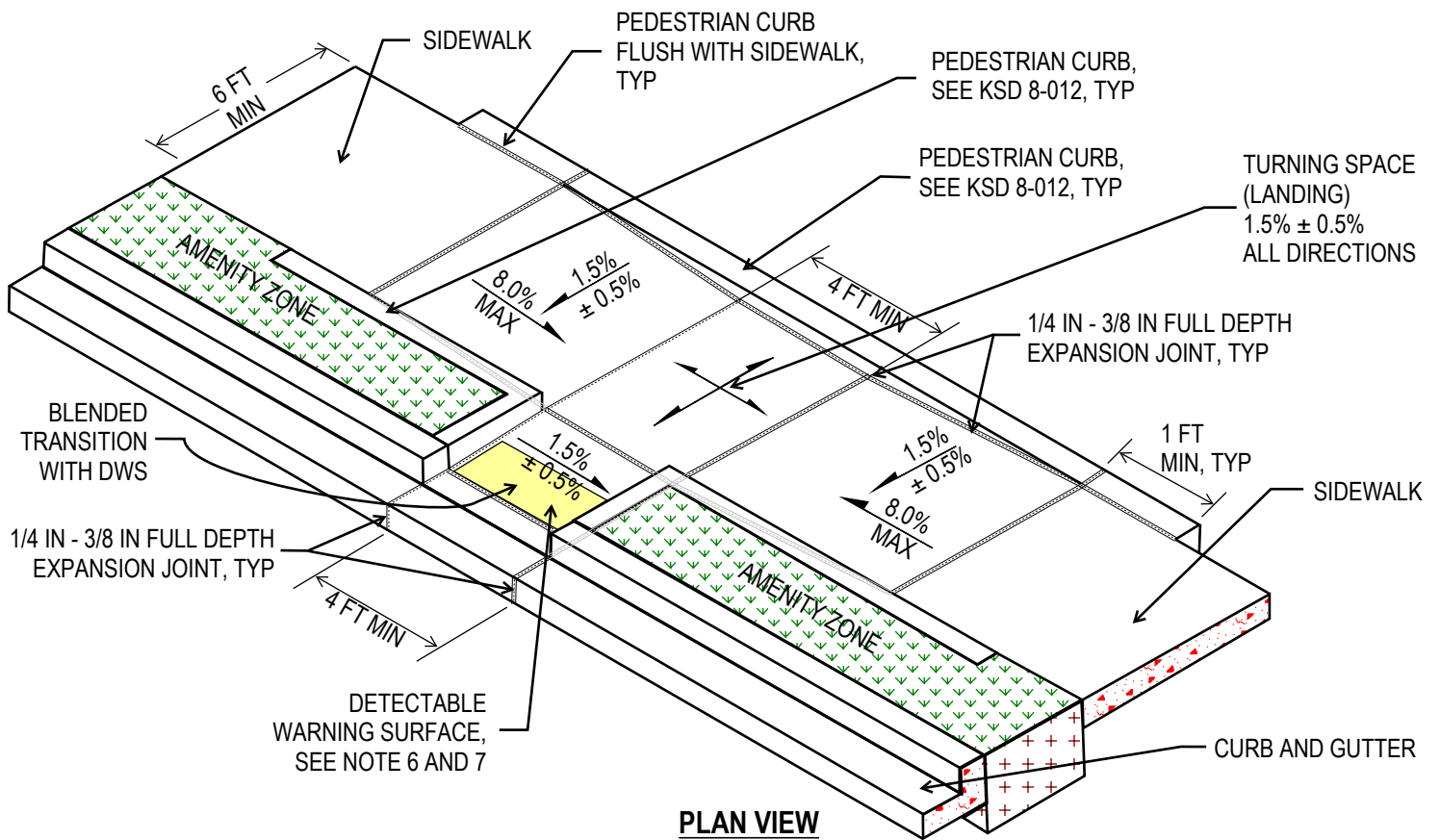

- NOTES:**
1. ALLOWABLE SLOPES AND WIDTHS ARE SHOWN. VARIATIONS FROM THE ABOVE STANDARDS MAY BE APPROVED AT THE DISCRETION OF THE CITY ENGINEER. RAMP MAY EXCEED 8.33% IF THE LENGTH IS A MINIMUM OF 15 FT.
 2. BACKFILL MATERIAL PER WSDOT STANDARD SPECIFICATION SECTION 9-03.
 3. DEPRESSED CURB MUST BE FLUSH WITH ADJACENT GUTTER AND CURB RAMP ±1/8 IN.
 4. ALL CONCRETE PANELS SHALL BE FLUSH WITH ADJACENT CONCRETE PANELS WITH NO GREATER THAN 1/8 IN VERTICAL DIFFERENCE.
 5. SEE KSD 4-001 FOR ADDITIONAL CURB RAMP PLACEMENT REQUIREMENTS.
 6. DETECTABLE WARNING PATTERN (DWS) SHALL BE FLUSH WITH SURROUNDING RAMP AND DEPRESSED CURB ±1/8 IN. DWS AND GRADE BREAKS SHALL BE PERPENDICULAR TO DIRECTION OF PEDESTRIAN TRAVEL. DWS SHALL BE WITHIN 5 FEET OF CURB.
 7. DWS SHALL BE COMPLIANT WITH ADA GUIDELINES AND BE COMPOSED OF POLYMER MATERIAL ONLY. COLOR SHALL BE YELLOW MATCHING FEDERAL STANDARD 595 COLOR NUMBER 33538. COLOR SHALL BE THROUGHOUT (SURFACE COATINGS ONLY NOT ALLOWED). DWS SHALL BE CAST IN PLACE, SURFACE MOUNT DWS ARE NOT ALLOWED.
 8. CATCH BASINS AND INLETS SHALL BE INSTALLED A MINIMUM OF 1 FOOT UPSTREAM FROM THE BASE OF ANY CURB RAMP.
 9. RAMP AND TURNING SPACE SHALL NOT HAVE ANY EXPANSION JOINTS EXCEPT ALONG BORDERS.
 10. FOR EXISTING SIDEWALK/RAMP LOCATIONS, CONCRETE SHALL BE REMOVED FROM JOINT TO JOINT; NO SAWCUTTING IS PERMITTED.



CITY OF KENMORE

ENGINEERING DEPARTMENT
(425) 398-8900



**COMBINATION
CURB RAMP**

**FIGURE 8-004
NOT TO SCALE**

Date: 06/21/2022

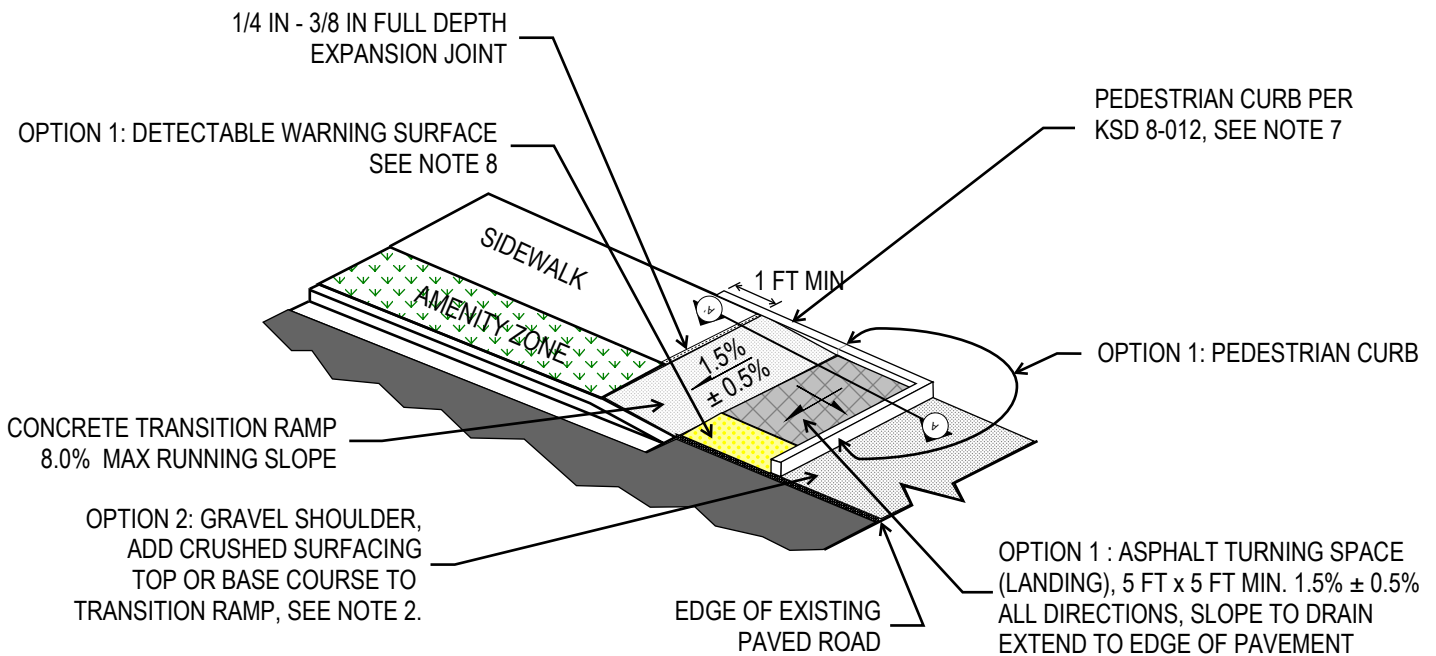

PLAN VIEW

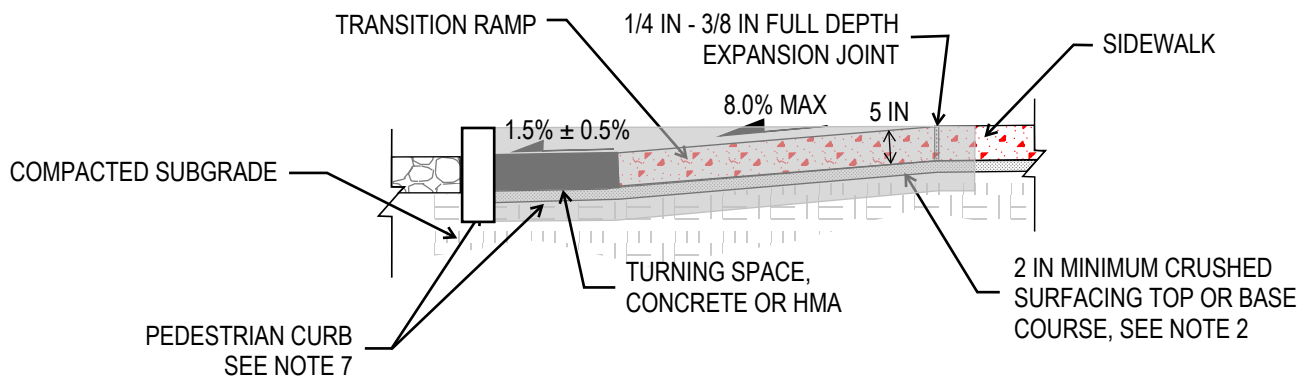

RAMP CROSS SECTION A-A'

OPTION 1: SHOULDER IS OBSTRUCTED PROVIDING LESS THAN 4 FEET OF WIDTH
 OPTION 2: SHOULDER PROVIDES A MINIMUM OF 4 FEET OF UNOBSTRUCTED WIDTH

NOTES:

1. ALLOWABLE SLOPES AND WIDTHS ARE SHOWN. VARIATIONS FROM THE ABOVE STANDARDS MAY BE APPROVED AT THE DISCRETION OF THE CITY ENGINEER. RAMP MAY EXCEED 8.33% IF THE LENGTH IS A MINIMUM OF 15 FT.
2. BACKFILL MATERIAL PER WSDOT STANDARD SPECIFICATION SECTION 9-03.
3. DEPRESSED CURB MUST BE FLUSH WITH ADJACENT GUTTER AND CURB RAMP $\pm 1/8$ IN.
4. ALL CONCRETE PANELS SHALL BE FLUSH WITH ADJACENT CONCRETE PANELS WITH NO GREATER THAN $1/8$ IN VERTICAL DIFFERENCE.
5. CATCH BASINS AND INLETS SHALL BE INSTALLED A MINIMUM OF 1 FOOT UPSTREAM FROM THE CURB TRANSITION.
6. RAMP AND TURNING SPACE SHALL NOT HAVE ANY EXPANSION JOINTS EXCEPT ALONG BORDERS.
7. PEDESTRIAN CURB REQUIRED FOR ALL RAMPS ADJACENT TO SLOPES STEEPER THAN 4H:1V THAT ARE WITHIN 2 FEET OF THE EDGE OF TURNING SPACE.
8. SEE KSD 8-002 FOR DETECTABLE WARNING SURFACE REQUIREMENTS.
9. GRADE BREAKS SHALL BE PERPENDICULAR TO DIRECTION OF TRAVEL.



CITY OF KENMORE

ENGINEERING DEPARTMENT
 (425) 398-8900



**TRANSITION RAMP
 TO SHOULDER**

FIGURE 8-005

NOT TO SCALE

Date: 05/26/2023

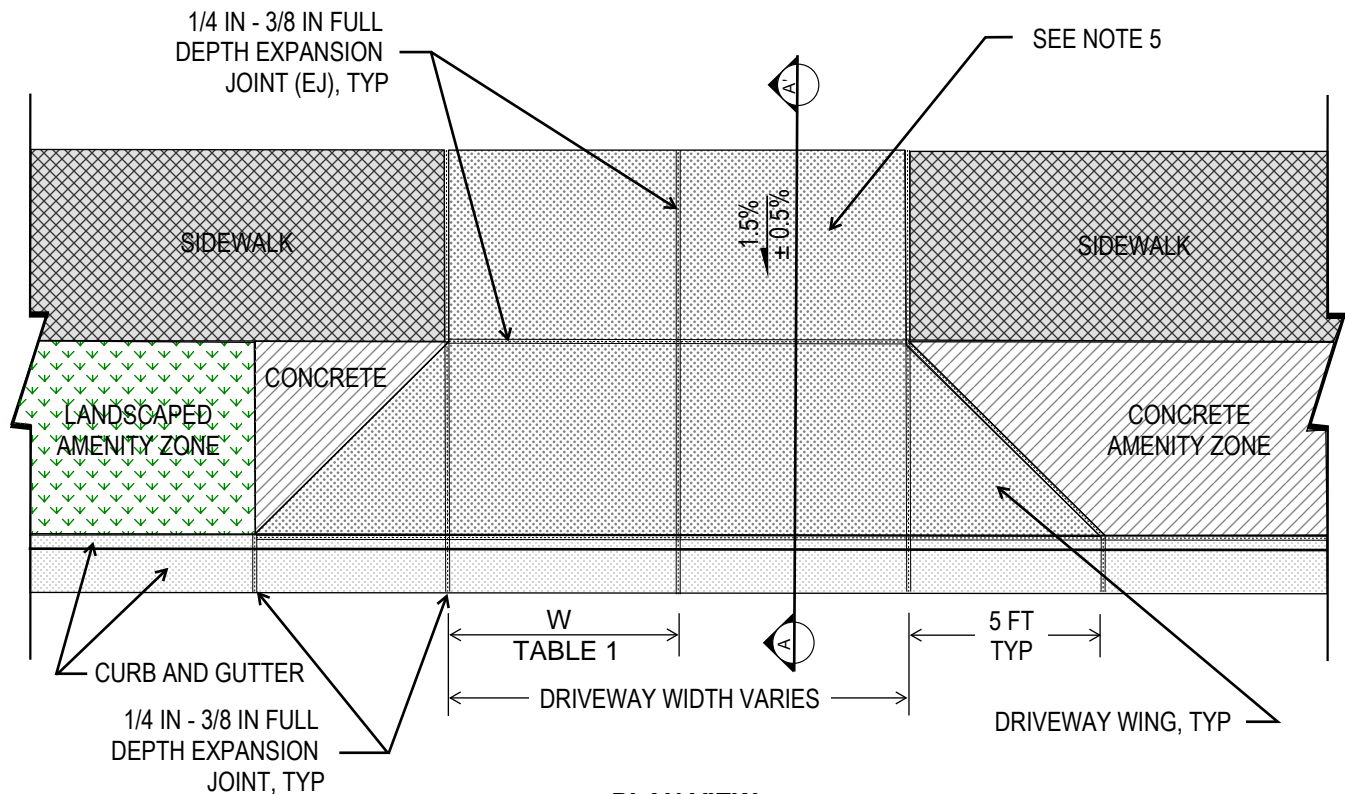

PLAN VIEW

TABLE 1	
DRIVEWAY WIDTH	W
<24 FT	1 EJ, CENTER ON DRIVEWAY WIDTH
≥24 FT	2 EJ, EQUALLY SPACED

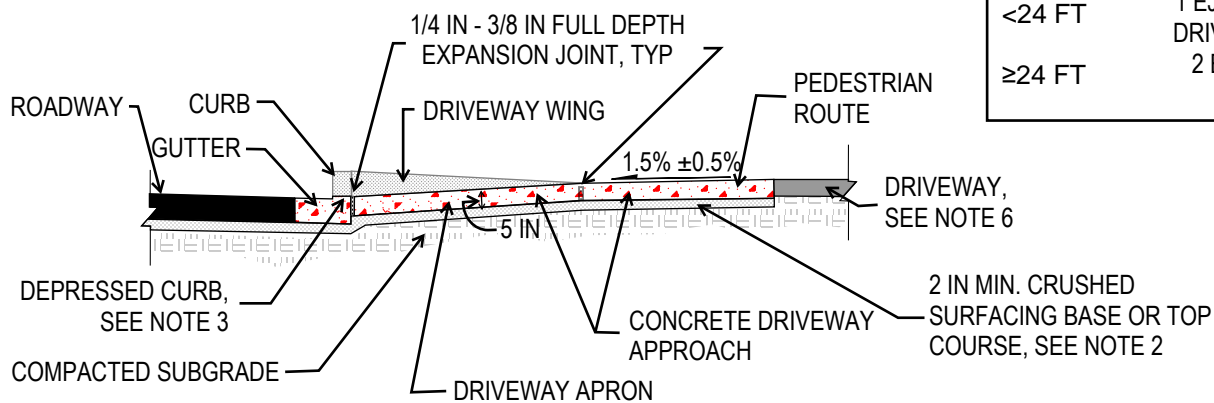

SECTION A-A'

- NOTES:
1. ALLOWABLE SLOPES AND WIDTHS ARE SHOWN. VARIATIONS FROM THE ABOVE STANDARDS MAY BE APPROVED AT THE DISCRETION OF THE CITY ENGINEER.
 2. BACKFILL MATERIAL PER WSDOT STANDARD SPECIFICATION SECTION 9-03.
 3. DEPRESSED CURB TO BE BETWEEN 1/2 IN AND 1 IN HIGH.
 4. ALL CONCRETE PANELS SHALL BE FLUSH WITH ADJACENT CONCRETE PANELS WITH NO GREATER THAN 1/8 IN VERTICAL DIFFERENCE.
 5. SEE KSD 8-001 (SIDEWALKS) FOR LOCATIONS OF DUMMY JOINTS AND ADDITIONAL EXPANSION JOINTS IN SIDEWALK IN DRIVEWAY APPROACH. JOINTS IN DRIVEWAY APRON TO MATCH THAT OF ADJACENT PEDESTRIAN ROUTE
 6. FOR CONCRETE DRIVEWAYS, INSTALL 1/4 IN TO 3/8 IN FULL DEPTH EXPANSION JOINTS BETWEEN DRIVEWAY AND BACK OF DRIVEWAY APPROACH AND AT THE RIGHT OF WAY LINE.
 7. SEE KSD 8-009 (CURBS) FOR CURB AND GUTTER REQUIREMENTS
 8. FOR EXISTING SIDEWALK/DRIVEWAY LOCATIONS, CONCRETE SHALL BE REMOVED FROM JOINT TO JOINT; NO SAWCUTTING IS PERMITTED.



CITY OF KENMORE

ENGINEERING DEPARTMENT
(425) 398-8900



**DRIVEWAY APPROACH
TYPE 1**

FIGURE 8-006

NOT TO SCALE

Date: 05/26/2023

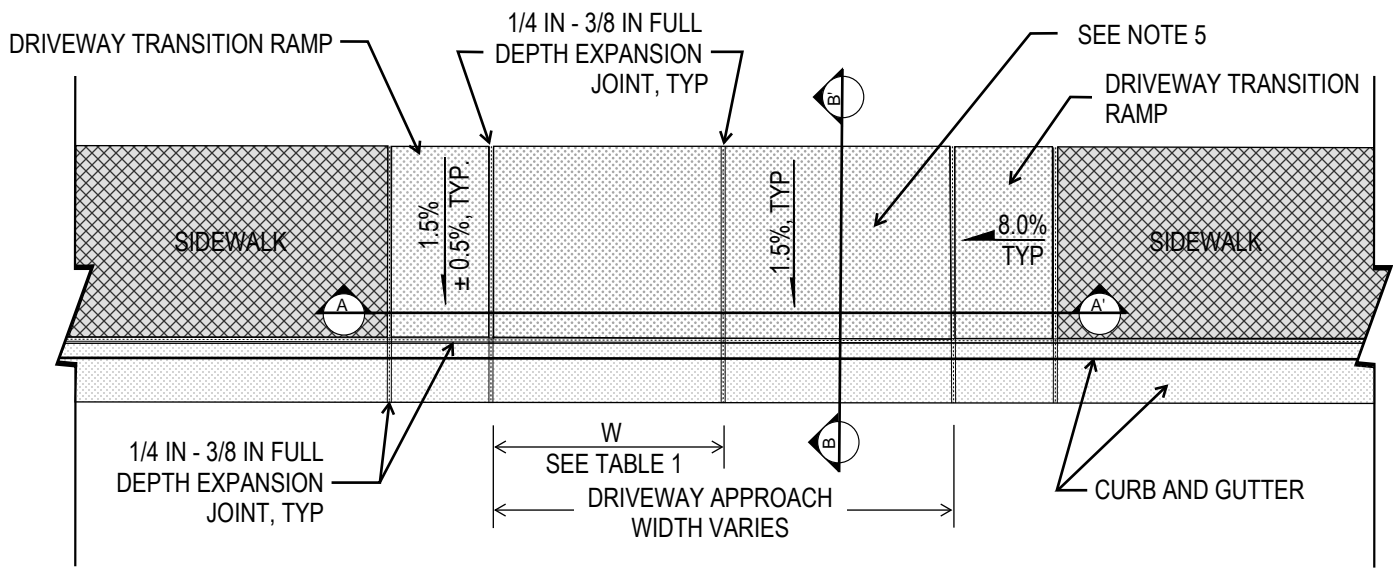

PLAN VIEW

TABLE 1	
DRIVEWAY WIDTH	W
<24 FT	1 EJ, CENTER ON DRIVEWAY WIDTH
≥24 FT	2 EJ, EQUALLY SPACED

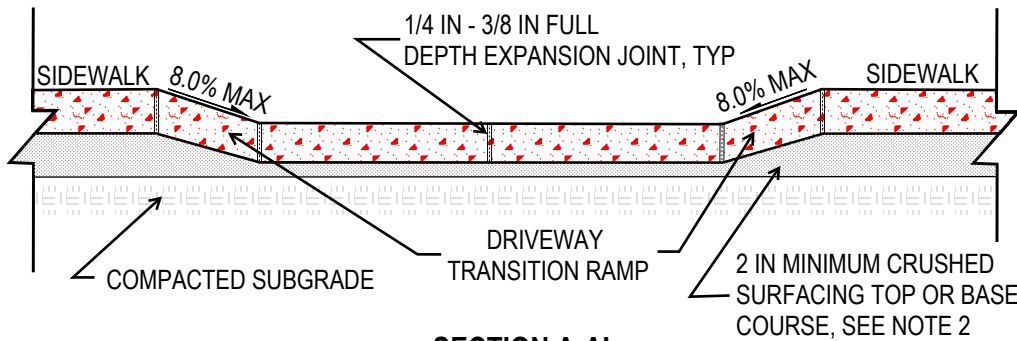

SECTION A-A'

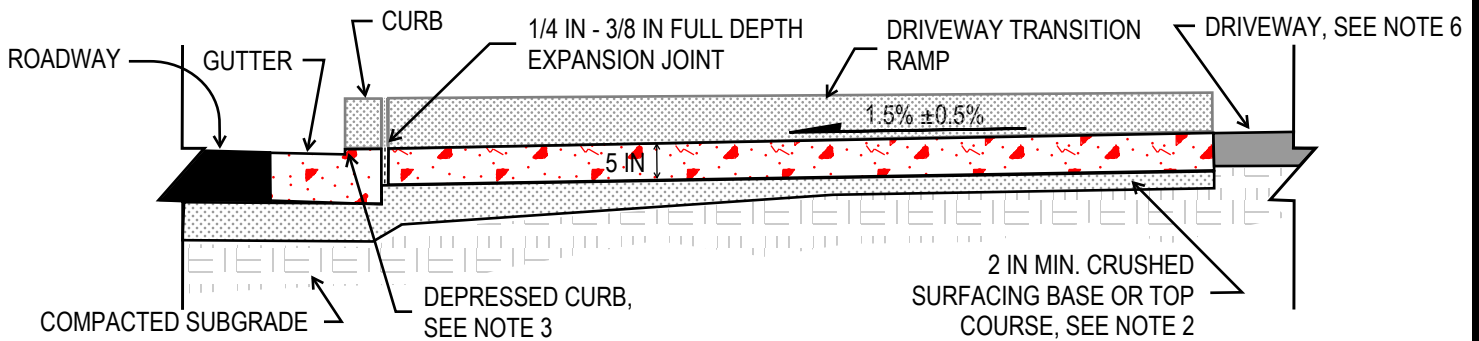

SECTION B-B'

- NOTES:
1. ALLOWABLE SLOPES AND WIDTHS ARE SHOWN. VARIATIONS FROM THE ABOVE STANDARDS MAY BE APPROVED AT THE DISCRETION OF THE CITY ENGINEER. RAMP MAY EXCEED 8.33% IF THE LENGTH IS A MINIMUM OF 15 FT.
 2. BACKFILL MATERIAL PER WSDOT STANDARD SPECIFICATION SECTION 9-03.
 3. DEPRESSED CURB TO BE BETWEEN 1/2 IN AND 1 IN HIGH.
 4. ALL CONCRETE PANELS SHALL BE FLUSH WITH ADJACENT CONCRETE PANELS WITH NO GREATER THAN 1/8 IN VERTICAL DIFFERENCE.
 5. SEE KSD 8-001 (SIDEWALKS) FOR LOCATIONS OF DUMMY JOINTS AND ADDITIONAL EXPANSION JOINTS IN DRIVEWAY APPROACH.
 6. FOR CONCRETE DRIVEWAYS, INSTALL 1/4 IN TO 3/8 IN FULL DEPTH EXPANSION JOINTS BETWEEN DRIVEWAY AND BACK OF DRIVEWAY APPROACH AND AT THE RIGHT OF WAY LINE.
 7. SEE KSD 8-009 (CURBS) FOR CURB AND GUTTER REQUIREMENTS.
 8. FOR EXISTING SIDEWALK/DRIVEWAY LOCATIONS, CONCRETE SHALL BE REMOVED FROM JOINT TO JOINT; NO SAWCUTTING IS PERMITTED.



CITY OF KENMORE

ENGINEERING DEPARTMENT
(425) 398-8900



**DRIVEWAY APPROACH
TYPE 2**

FIGURE 8-007

NOT TO SCALE

Date: 05/26/2023

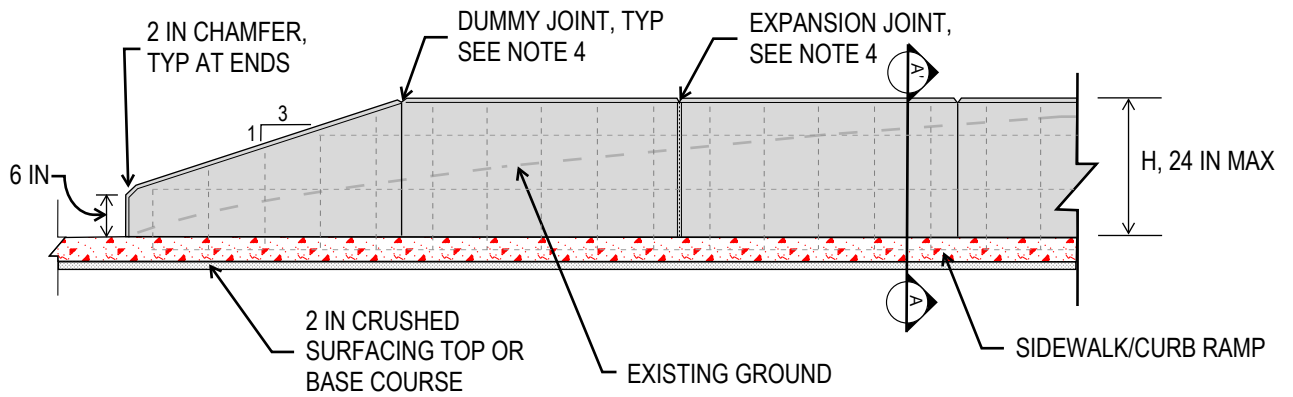

PROFILE VIEW

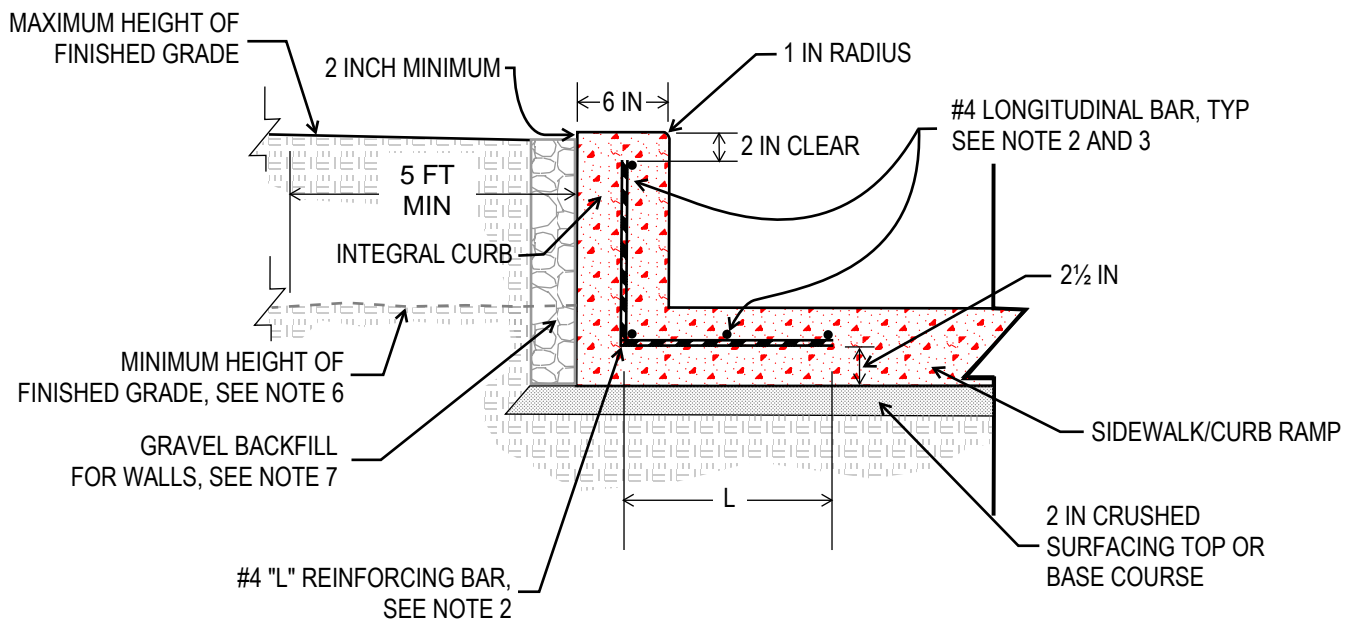

CROSS SECTION A-A'

REINFORCING STEEL

INTEGRAL CURB HEIGHT (H)	L	NO. OF LONGITUDINAL BARS	
		SIDEWALK	INT. CURB
6 IN - 12 IN	2 FT	3	1
12 IN - 24 IN	3 FT	4	2

- NOTES:**
- CURB TO BE POURED INTEGRAL WITH SIDEWALK
 - SPACE BARS A MAXIMUM OF 1 FOOT ON CENTER.
 - NUMBER OF BARS PER REINFORCING STEEL TABLE. PROVIDE CONTINUOUS REINFORCEMENT WITH A MINIMUM OF 2 FT OVERLAP.
 - BACKFILL MATERIAL PER WSDOT STANDARD SPECIFICATION SECTION 9-03.
 - ALIGN INTEGRAL CURB JOINTS WITH SIDEWALK JOINTS, MATCH SIZE, AND TYPE.
 - THICKENED EDGE SIDEWALK PER KSD 8-011 REQUIRED FOR FINISHED GRADE BELOW TOP OF SIDEWALK FINISH ELEVATION.
 - A WALL DRAIN AND CONNECTION TO THE STORM DRAINAGE SYSTEM REQUIRED FOR SUBGRADE SOIL INFILTRATION RATES LESS THAN 0.6 INCHES PER HOUR. SEE KSD 3-003 FOR DRAIN CONNECTION DETAIL.



CITY OF KENMORE

ENGINEERING DEPARTMENT
(425) 398-8900



**INTEGRAL CURB
SIDEWALK**

FIGURE 8-010

NOT TO SCALE

Date: 05/26/2023

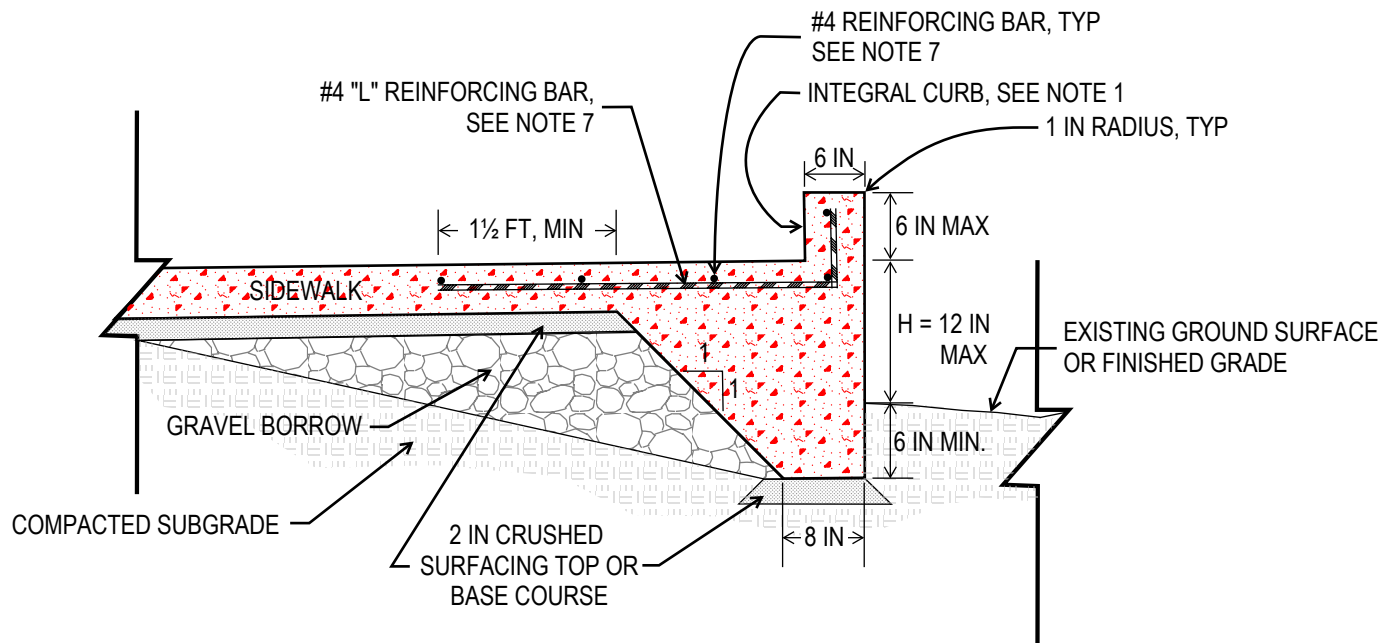

THICKENED EDGE WITH INTEGRAL CURB

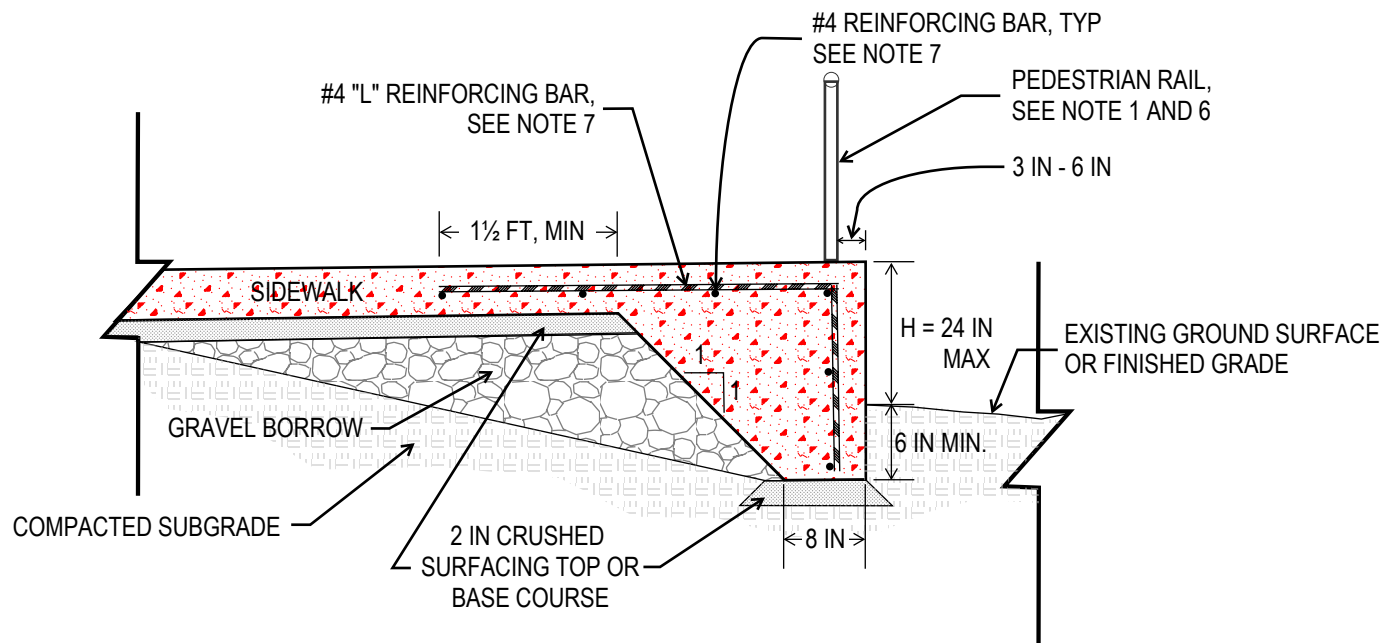

THICKENED EDGE WITH RAIL

NOTES:

1. INTEGRAL CURB MAY BE USED IN LIEU OF PEDESTRIAN RAIL FOR "H" LESS THAN 18 INCHES. CURB TO BE POURED INTEGRAL WITH SIDEWALK.
2. 2 INCHES MINIMUM COVER FOR REINFORCING BAR.
3. BACKFILL MATERIAL PER WSDOT STANDARD SPECIFICATION SECTION 9-03.
4. ALIGN INTEGRAL CURB JOINTS WITH SIDEWALK JOINTS, MATCH SIZE, AND TYPE.
5. CONSTRUCT TAPERED INTEGRAL CURB ENDS AT 1:1 TO MATCH SIDEWALK FINISHED GRADE
6. PEDESTRIAN RAIL PER KSD 6-006.
7. SPACE BARS A MAXIMUM OF 12 INCHES ON CENTER. CONTINUOUS THROUGH EXPANSION JOINTS. 12 INCHES MINIMUM OVERLAP.



CITY OF KENMORE

ENGINEERING DEPARTMENT
(425) 398-8900



**THICKENED EDGE
SIDEWALK**

FIGURE 8-011

NOT TO SCALE

Date: 2/26/2021

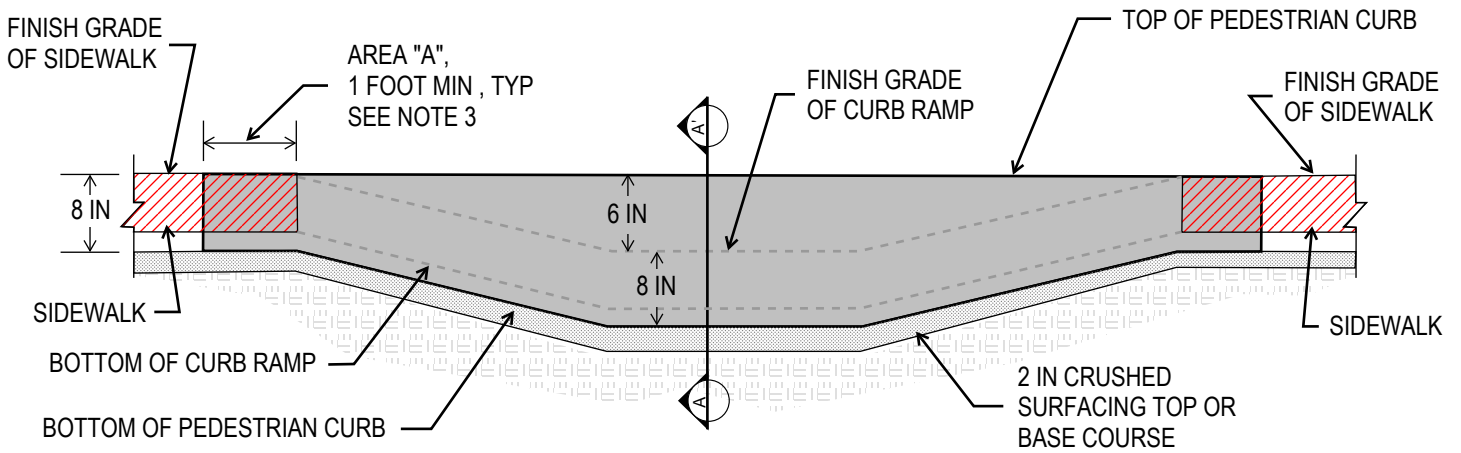

PEDESTRIAN CURB PROFILE

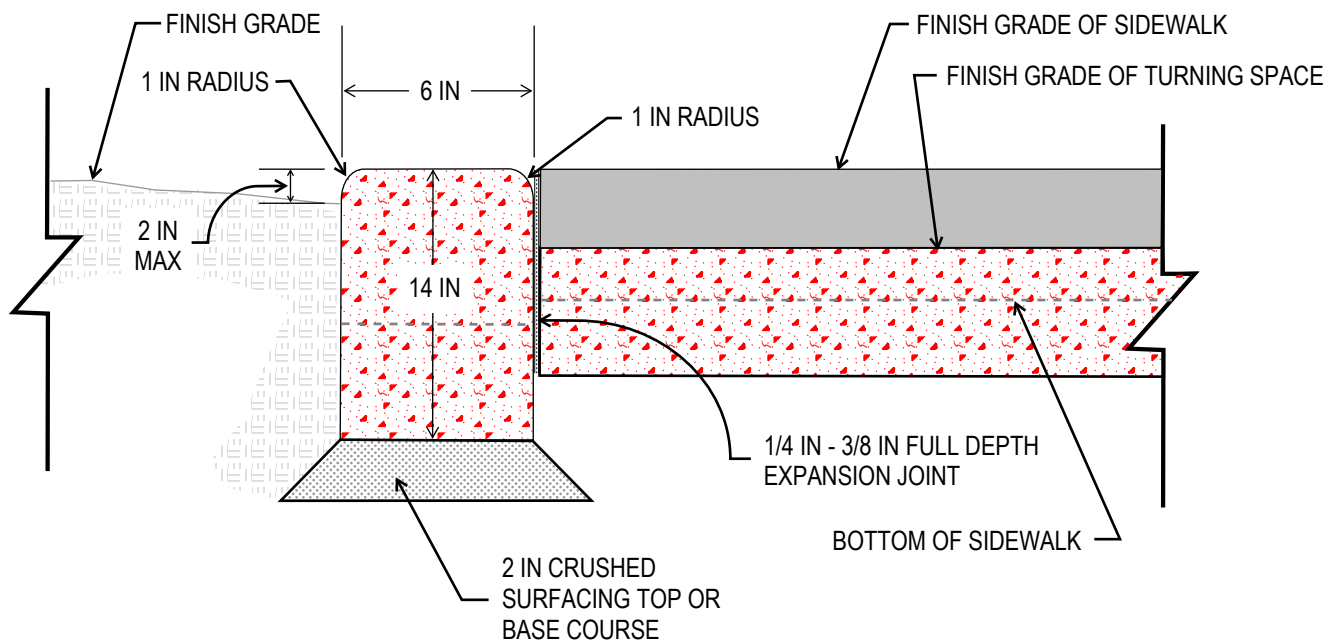

CROSS SECTION A-A'

NOTES:

1. FULL DEPTH EXPANSION JOINT BETWEEN SIDEWALK/CURB RAMP AND PEDESTRIAN CURB, FULL LENGTH OF CURB
2. BACKFILL MATERIAL PER WSDOT STANDARD SPECIFICATION SECTION 9-03.
3. PEDESTRIAN CURB TO BE FLUSH WITH TOP OF SIDEWALK IN AREA "A"
4. PEDESTRIAN CURB MAY ONLY BE USED WHERE BACK OF CURB IS BACKFILLED WITHIN 6 INCHES TO TOP OF CURB. INTEGRAL CURB WALL PER KSD 8-010 SHALL BE USED FOR DEPTHS GREATER THAN 6 INCHES
5. FOR PEDESTRIAN CURB AT SIDEWALK SIDE SLOPES, PEDESTRIAN CURB SHALL BE POSITIONED TO PROVIDE A 6 INCH CURB HEIGHT ABOVE THE SIDEWALK.



CITY OF KENMORE

ENGINEERING DEPARTMENT
(425) 398-8900



PEDESTRIAN CURB

FIGURE 8-012

NOT TO SCALE

Date: 05/26/2023



APPENDIX F

SURFACE WATER MANUAL ADDENDUM

CITY OF KENMORE

SURFACE WATER DESIGN MANUAL ADDENDUM

General Introduction

The State of Washington Department of Ecology (Ecology), in compliance with the provisions of Washington Water Pollution Control Law Chapter 90.48 Revised Code of Washington and The Federal Water Pollution Control Act (Clean Water Act) has issued the City a National Pollutant Discharge Elimination System (NPDES) Western Washington Phase II Municipal Stormwater permit (Permit) requiring the City to adopt either the 2019 Ecology Stormwater Management Manual for Western Washington or a current Phase I program approved by Ecology by June 30, 2022. The King County 2021 Surface Water Design Manual and referenced 2021 King County Stormwater Pollution Prevention Manual provide an Ecology approved Phase I program meeting the City's Permit requirements.

The City of Kenmore adopted the 2021 King County Surface Water Design Manual (SWDM) via Ordinance 22-0551 on June 21, 2022 with an effective date of June 30, 2022.

Purpose of and Need for the Addendum

This Addendum to the SWDM defines how the requirements of the SWDM are to be implemented within the City of Kenmore. The Addendum specifies all changes, additions, and deletions to the SWDM to make it appropriate for use within the City of Kenmore. The SWDM along with this Addendum define the drainage requirements for development, redevelopment and construction sites within the city.

The purpose of this Addendum is to tailor the SWDM to meet the unique conditions within the City, and be consistent with the City's codes, organization and processes. No substantive changes have been made to the SWDM in order to maintain equivalency in requirements and the level of protection provided by the SWDM.

Relationship of the SWDM and the City of Kenmore Development Code to Low Impact Development (LID)

The City of Kenmore adopted code amendments that minimize the loss of native vegetation and reduce runoff from developed sites. The SWDM requires on site flow control best management practices (BMPs) to mitigate the impacts of storm and surface water runoff generated by new impervious surfaces, new pervious surfaces, existing impervious surfaces, and replaced impervious surfaces. Flow control BMPs are methods to disperse, infiltrate, or otherwise reduce or prevent development related increases in runoff at or near the sources of those increases. The SWDM provides specific design guidance for implementation of the LID

measures encouraged in the City's development code. As a result, the SWDM and the City of Kenmore development code complement each other.

How to Use this Document

This Addendum shall be used in coordination with the SWDM for the following:

- To translate specific wording or reference from King County to the City.
- To cross-reference City ordinances and City maps in lieu of King County ordinances and maps.
- To provide a linkage or reference to other City requirements such as more restrictive requirements outlined in basin plans and the City's Critical Areas Ordinances.
- To provide exceptions and additions to the SWDM.

The SWDM shall be used in its entirety except as directed in this Addendum. Exceptions and additions to the SWDM are organized and referenced by chapter and section in the same manner as the SWDM. Some global changes are provided in this preface, which shall be applied throughout the entire SWDM. The user shall override the maps and references to other documents as indicated within this Addendum.

Addendum Organization

The information presented in this Addendum is organized as follows:

- **Preface:** This preface provides instructions for using the City of Kenmore's Addendum to the SWDM. It also defines terms in the SWDM that are used differently for the City of Kenmore; City departments that are equivalent to county departments referred to in the SWDM; and designations from the SWDM that do not apply to proposals in the City of Kenmore.
- **Chapter 1 – Drainage Review and Requirements:** The City of Kenmore has made several changes to Chapter 1 of the SWDM. This Addendum provides replacement and supplemental text for specific sections of Chapter 1. Apart from these changes, the King County version of Chapter 1 applies to proposals in the City of Kenmore.
- **Chapter 2 – Drainage Plan Submittal:** The City of Kenmore has made minor changes to Chapter 2 of the SWDM. Section 2.4.2 has been modified to include an additional requirement for the inspection of installed LID BMPs. The King County version of Chapter 2 applies to proposals in the City of Kenmore, except that the applicant shall refer to the City of Kenmore documents for technical submittal requirements, project plan requirements, and as-built requirements.
- **Chapter 3 – Hydrologic Analysis and Design:** The City of Kenmore has made no changes to Chapter 3 of the SWDM. The King County version of Chapter 3 applies to proposals in the

City of Kenmore.

- **Chapter 4 – Conveyance System Analysis and Design:** The City of Kenmore has made minor changes to Chapter 4 of the SWDM. More stringent requirements for allowable pipe materials, deflection, maximum distance between structures, and other requirements are listed in the City of Kenmore Addendum. Apart from these changes, the King County version of Chapter 4 applies to proposals in the City of Kenmore.
- **Chapter 5 – Flow Control Design:** The City of Kenmore has made very minor changes to Chapter 5 of the SWDM. This addendum to Chapter 5 provides replacement text for the sections that are changed. Apart from these changes, the King County version of Chapter 5 applies to proposals in the City of Kenmore.

The City of Kenmore has adopted a Low Impact Development Ordinance that encourages the use of LID site planning techniques within the City. LID site planning techniques can help to reduce the size of flow control facilities required in the SWDM.

- **Chapter 6 – Water Quality Design:** The City of Kenmore has made minor changes to Chapter 6 of the SWDM. This addendum to Chapter 6 provides replacement text for the sections that are changed. Apart from these changes, the King County version of Chapter 6 applies to proposals in the City of Kenmore.

The City of Kenmore amends Chapter 6 of the SWDM to allow for bioretention to be utilized as a pretreatment facility.

- **Definitions:** The City of Kenmore has made changes to the definitions section of the SWDM. This Addendum to the Definitions section provides replacement text for the definitions that are changed. Apart from these changes, the King County version of the Definitions Section applies to proposals in the City of Kenmore.
- **Appendices:** Appendices A, C, and D apply to proposals in the City of Kenmore, Appendix B does not apply.
- **References:** King County Reference sections 1, 2, 3, 4A, 4B, 7, 8 and 10 do not apply to the City of Kenmore. King County Reference section 8 has been replaced by a City of Kenmore Reference section 8. The King County version of Reference section 4C, 4D, 5, 6, 9, 11 and 14 apply to proposals in the City of Kenmore.

City Equivalents for County Agencies

Unless the context requires otherwise, any reference to “County”, “King County”, or county department, shall refer to the City of Kenmore and any reference to county staff shall refer to the City Manager or designee, unless referring to a specific department.

City Equivalents for County Ordinances

For proposals in the City of Kenmore, all reference in the SWDM to the following ordinances or municipal codes shall be replaced by reference as indicated in the following table.

King County Code (KCC)	Description	Kenmore Municipal Code (KMC)	Description
KCC 16.82	Clearing and Grading	Chapter 15.25 KMC	Land Alterations
KCC 21A.14	Development Standards Design Requirements	Chapters 18.21 – 18.52 KMC	Development Standards included within each zoning classification
KCC 21A.24	Critical Areas	Chapter 18.55 KMC	Critical Areas
KCC 21A.06	Technical Terms and Land Use Definitions	Chapter 18.20 KMC	Technical Terms and Land Use Definitions
KCC 20.14	Basin Plans		Surface Water Master Plan
KCC 9	Surface Water Management	Chapter 13.35 KMC Chapter 13.40 KMC Chapter 13.45 KMC	Surface Water Runoff Policy Surface Water Management Policy Water Quality

City Equivalents for Critical Areas

In general, references to the King County Critical Areas Ordinance (KCC 21A) are to be replaced by reference to the Kenmore Municipal Code (Chapter 18.55 KMC), Critical Areas. Definitions for critical areas and terminology may be found in Chapter 18.20 KMC. Additional details and development standards for critical areas can be found in Chapter 18.55 KMC.

City Equivalents for County Maps

For proposals in the City of Kenmore, all reference in the SWDM to the following maps shall be replaced by reference as indicated in the following table.

King County Map or Designation	City of Kenmore Map
Flow Control Applications Map	The King County Flow Control Applications Map included with the SWDM shall not be applied in the City of Kenmore. The Swamp Creek basin is a flood problem flow control area (level 3) and the remainder of the City of Kenmore is a conservation flow control area (level two) except for project sites with identified downstream flooding problems that may require a higher level of flow control for impact mitigation.
Water Quality Applications Map	The King County Water Quality Applications Map included with the SWDM shall not be applied in the City of Kenmore. All of the City of Kenmore is a basic water quality treatment area unless the proposed land use triggers enhanced basic water quality treatment.
Erosion Hazard Near Sensitive Water Bodies Map in KCC 21A.38.210	The King County Erosion Hazard Near Sensitive Water Bodies mapping included with the SWDM shall not apply in the City of Kenmore.
Flood Hazard Area as defined in KCC 21A.06	The King County Flood Hazard Area mapping included with the SWDM shall not apply in the City of Kenmore. Flood hazard areas are depicted on the City of Kenmore Critical Areas Online GIS map on the City’s website.
Erosion Hazard Area	The King County Erosion Hazard Area mapping included with the SWDM shall not apply in the City of Kenmore. Erosion hazard areas are depicted on the City of Kenmore Critical Areas Mapping: Geological Hazard Areas map.
Landslide Hazard Area	The King County Landslide Hazard Area mapping included with the SWDM shall not apply in the City of Kenmore. Landslide hazard areas are depicted on the City of Kenmore Critical Areas Mapping: Geological Hazard Areas map [KMC 13.32.390].

City Equivalents for County Plans or Studies

In general, references to county-approved plans or studies in the SWDM are to be replaced by reference to appropriate City-approved plans or studies. If comparable City- approved plans or studies do not exist, then references to County-approved plans or studies shall be retained for proposals in the City of Kenmore.

County Designations that do not Apply in the City

The following designations are used in the SWDM but are not currently used in the City of

Kenmore; any reference in the SWDM to the existence of areas with these designation or thresholds or requirements for such areas is to be disregarded for proposals in the City of Kenmore:

- **Agricultural Project**
- **Forest Production Zone Area**
- **Master Drainage Plans (MDPs)**
- **Rural Residential Development**
- **Sensitive Area Folio** - refer to City of Kenmore Critical Areas Maps
- **Stormwater Compliance Plans (SWCPs)**
- **Urban Planned Development**
- **Zoning Classifications:** The SWDM references to Agricultural (A) Zoning, Forest (F) Zoning, or Rural (R) Zoning are intended for areas outside of the Urban Growth Boundary; therefore, the City of Kenmore contains no equivalent zoning. Project proponents should refer to City zoning maps to determine which zoning classifications apply to their projects.

CHAPTER 1 – Drainage Review and Requirements

The City of Kenmore has made several minor changes to Chapter 1 of the SWDM. This chapter provides replacement and supplemental text for specific sections of Chapter 1. Apart from these changes, the King County version of Chapter 1 applies for proposals in the City of Kenmore. The City’s changes to the County document are as follows:

- **Key Terms and Definitions (page 1-1 of the SWDM)** — Replace all references to KCC 21A with Chapter 18.20 KMC. In addition, the following changes to specific terms apply:

Term (page)	Action
Critical Drainage Area (p 1-2)	<p><i>Replace as follows per Section 13.35.040 KMC:</i></p> <p>Critical drainage areas are sites where the city manager has determined that the existing flooding, drainage and/or erosion conditions present an imminent likelihood of harm to the welfare and safety of the surrounding community shall meet special drainage requirements set by the city manager until such time as the community hazard is alleviated.</p> <p>Critical drainage areas are regulated in Section 13.35.040 KMC Critical drainage and/or erosion areas.</p>
Erosion hazard area (p 1-3)	<p><i>Replace as follows per Section 18.20.940 KMC:</i></p> <p>Erosion hazard areas are those areas identified by the United States Department of Agriculture Natural Resources Conservation Service or identified by a special study as having a “moderate to severe” or “very severe” erosion potential.</p> <p>Erosion hazard areas are defined in Section 18.20.940 KMC Erosion hazard areas and regulated under Section 18.55.600 KMC through Section 18.55.650 KMC.</p>
Flood Hazard Area (p 1-3)	<p><i>Replace as follows per Section 18.20.1070 KMC:</i></p> <p>Flood hazard areas are those areas in the City subject to inundation by the base flood and those areas subject to risk from channel relocation or stream meander including, but not limited to, streams, lakes, wetlands and closed depressions.</p> <p>Flood hazard areas are regulated in Section 18.55.700 KMC through Section 18.55.795 KMC.</p>

Term (page)	Action
Landslide Hazard Area (p 1-5)	<p><i>Replace as follows per Section 18.55.1570 KMC:</i></p> <p>Landslide hazard areas are areas that are potentially subject to risk of mass movement resulting from a combination of geologic, topographic, and hydrologic factors including: bedrock, soil, slope gradient, slope aspect, geologic structure, ground water, or other factors. [Ord. 11-0329 § 3 (Exh. 1).]</p> <p>Landslide hazard areas are regulated in Section 18.55.600 KMC through Section 18.55.650 KMC.</p>

- **SECTION 1.1.1 PROJECTS REQUIRING DRAINAGE REVIEW (page 1-12 of the SWDM)** Replace the “King County Permits and Approvals” table with the following table and replace the text in number 4 with:

4. The project contains or is adjacent to a flood hazard area as defined in *Section 18.55.705 KMC*, OR

Add the following as a new number 7 and 8:

- 7. Is a redevelopment project on a site where the total of new plus replaced impervious surface is 5,000 square feet or more, and whose valuation of proposed improvements – including interior improvements and excluding required mitigation and frontage improvements – exceeds 50 percent of the assessed value of the existing site improvements.
- 8. The project adds or will result in 500 to 1,999 square feet of new impervious surface, replaced impervious surface, or new plus replaced impervious surface. These projects will follow Simplified Drainage Review but may be modified, with Department approval, to be appropriate for the scale and scope of the project and still meet the intent of the SWDM.

City of Kenmore Permits and Approvals	
<ul style="list-style-type: none"> • Administrative use permit • Amend adopted P-suffix conditions • Binding site plan • Boundary line adjustment • Building permit • Grading permit • Conditional use permit • Master plan development permit • Planned unit development 	<ul style="list-style-type: none"> • Reasonable use exception • Right-of-way permit • Short plat • Short plat alteration • Site plan review • Subdivision • Subdivision alteration • Unclassified use permit • Variance

- Section 1.2 CORE REQUIREMENTS, Section 1.2.2.1.2 Downstream Water Quality Problems Requiring Special Attention (page 1-30 of the SWDM)** — The following supplemental information is added to this section:

The SWDM recognizes water quality problems requiring special mitigation measures to protect receiving waters. A water quality problem is defined as a problem documented by the state to exceed the state’s numeric water quality standard. The SWDM references Category 2, 4, and 5 water quality problems as requiring special attention. Within the City of Kenmore, the following water quality problems are currently listed by the Department of Ecology, based on the 2015 Water Quality Assessment, approved by the U.S. Environmental Protection Agency on July 22, 2016. The latest designated impaired waterbodies can be viewed at: <http://www.ecy.wa.gov/programs/Wq/303d/currentassessmt.html>

Impaired Water Body	Parameter	Category*
Sammamish River	Bacteria, Dissolved Oxygen, and Temperature	5
Swamp Creek	Temperature, Bioassessment, and Dissolved Oxygen	5
Swamp Creek	Mercury	2
Swamp Creek	Bacteria	4a
Unnamed creek (Trib to Swamp Creek – aka Little Swamp Creek)	Dissolved Oxygen, and Temperature	5
Unnamed creek (Trib to Swamp Creek – aka Little Swamp Creek)	Bacteria	4a
Unnamed Creek (Trib to Lake Washington – aka Tributary 0056)	Bioassessment	5
Lake Washington	Polychlorinated Biphenyls (PCBs) and Total Phosphorus	5

* *Definition of Categories for impaired waterbodies:*

- o *Category 2: Waters of concern, some evidence of water quality problem.*
- o *Category 4a: Water bodies that have an approved TMDL in place and are actively being implemented.*
- o *Category 5: Polluted waters, a TMDL plan is required.*

Projects that discharge to the impaired waterbodies identified above may be required to implement special treatment to address the water quality problem in accordance with the requirements outlined in Section 1.2.2.3, Water Quality Problem Impact Mitigation.

The federal Clean Water Act requires that a Total Maximum Daily Load (TMDL) cleanup plan be developed for each of the waterbodies on the state's list of impaired waterbodies, known as the "303(d) list." The TMDL study identifies pollution problems in the watershed and specifies how much pollution needs to be reduced or eliminated to achieve clean water.

- **SECTION 1.2.3 CORE REQUIREMENT NO. 3: FLOW CONTROL (page 1-38 of the SWDM)**

- The following statement shall be added to the flow control requirement: "infiltration of stormwater runoff shall be used wherever feasible."
- The remaining text of SWDM 1.2.3 Core Requirement No. 3: Flow Control, shall apply within the City of Kenmore.

- **Section 1.2.3.1 AREA-SPECIFIC FLOW CONTROL FACILITY REQUIREMENT**

- Section 1.2.3.1.A (Basic Flow Control Areas) shall not apply within the City of Kenmore.
- Section 1.2.3.1.B (Conservation Flow Control Areas) shall apply throughout the City of Kenmore, except where the City has determined that Flood Problem Flow Control is needed.
- Section 1.2.3.1.C (Flood Problem Flow Control Areas) shall apply within the Swamp Creek basin within the City of Kenmore.
- Section 1.2.3.1 "Impervious Surface Percentage Exemption for Agricultural Projects" (page 1-42 of the SWDM) is void and shall not apply within the City of Kenmore.
- Add new sections following "Impervious Surface Percentage Exemption for Agricultural Projects" (page 1-42 of the SWDM)

- **MAINTENANCE EXEMPTIONS**

The following pavement maintenance practices are exempt:

- a) Pothole and square cut patching
- b) Overlaying existing asphalt or concrete pavement with asphalt or concrete without expanding the area of coverage (overlaying permeable or pervious pavements with traditional (non-permeable) asphalt or pavement is not considered pavement maintenance)
- c) Shoulder grading

- d) Reshaping/regrading drainage systems
 - e) Crack Sealing
 - f) Resurfacing with in-kind material without expanding the road prism
 - g) Pavement preservation activities that do not expand the road prism
 - h) Vegetation maintenance
 - i) Catch basin and pipe maintenance
 - j) Regrading/reshaping/resurfacing of existing ramps or sidewalks to meet ADA requirements
 - k) Underground utility projects that replace the ground surface with in-kind material or materials with similar runoff characteristics.
 - l) Projects that do not impact the base course are exempt and are not considered “replaced impervious”.
- **MAINTENANCE NON-EXEMPTIONS**

The following pavement maintenance practices are not exempt:

- a) The practices subject to the Core Requirements that are triggered when the thresholds are met or exceeded. The extent to which the manual applies is explained for each circumstance.
 - b) Removing and replacing a paved surface and impacting the base course. If impervious surfaces are not expanded, Core Requirements #1, 5, 6, and 9 apply.
- **Section 1.2.8 CORE REQUIREMENT #8: WATER QUALITY**
 - Add the following new maintenance exemptions and non-exemptions under the section EXEMPTIONS FROM CORE REQUIREMENT #8 (page 1-69 of the SWDM)

5. MAINTENANCE EXEMPTIONS

The following pavement maintenance practices are exempt:

- a) Pothole and square cut patching

- b) Overlaying existing asphalt or concrete pavement with asphalt or concrete without expanding the area of coverage (overlaying permeable or pervious pavements with traditional (non-permeable) asphalt or pavement is not considered pavement maintenance)
- c) Shoulder grading
- d) Reshaping/regrading drainage systems
- e) Crack Sealing
- f) Resurfacing with in-kind material without expanding the road prism
- g) Pavement preservation activities that do not expand the road prism
- h) Vegetation maintenance
- i) Catch basin and pipe maintenance
- j) Regrading/reshaping/resurfacing of existing ramps or sidewalks to meet ADA requirements
- k) Underground utility projects that replace the ground surface with in-kind material or materials with similar runoff characteristics.
- l) Projects that do not impact the base course are exempt and are not considered "replaced impervious".

6. MAINTENANCE NON-EXEMPTIONS

The following pavement maintenance practices are not exempt.

- a) The practices subject to the Core Requirements that are triggered when the thresholds are met or exceeded. The extent to which the manual applies is explained for each circumstance.
- b) Removing and replacing a paved surface and impacting the base course. If impervious surfaces are not expanded, Core Requirements #1, 5, 6, and 9 apply.

CHAPTER 2 – Drainage Plan Submittal

The City of Kenmore has added supplemental information and made minor changes to Chapter 2 of the SWDM, as described below. Apart from this information, project proponents should refer to the county document for guidance on drainage plan submittal. All submittal reviews shall be conducted by the Department of Development Services (DDS).

Supplemental Information

As part of the SWDM the applicant shall refer to the following documents for Project Plans.

1. Grading Permit and Engineering Permit applications. The applications and associated checklists are provided on the City's website.

Section 2.4.2 FINAL CORRECTED PLAN SUBMITTAL (page 2-41 of the SWDM) — Add to Section 2.4.2:

During the course of construction, special inspections are required for LID and Flow Control BMPs. Once construction is completed, a qualified professional shall provide a signed letter verifying that the BMPs have been inspected, installed correctly, and are functioning as designed. Any as-built deviations from the approved permit plan set shall be explained clearly in the letter.

CHAPTER 3 – Hydrologic Analysis and Design

The City of Kenmore has made no changes to Chapter 3 of the SWDM. Project proponents should refer to the county document for guidance on hydrologic analysis and design.

CHAPTER 4 – Conveyance System Analysis and Design

The City of Kenmore has made minor changes to Chapter 4 of the SWDM. The following requirements apply as applicable in this chapter:

References to the King County Road Design and Construction Standards (KCRDCS) shall mean the City of Kenmore Road Standards.

1. Allowed Pipe Types (Replacing applicable section 4.2.1.1 of the SWDM):

Corrugated polyethylene (CPE) pipe, Polypropylene (PP) pipe, and Polyvinyl chloride (PVC) pipe are deleted and shall be replaced with the following allowed pipe and criteria:

- WSDOT Section 9-05.24 Polypropylene Culvert Pipe, Polypropylene Storm Sewer Pipe, and Polypropylene Sanitary Sewer Pipe
- All joints for polypropylene pipe shall be made with a bell/bell or bell and spigot coupling and shall conform to ASTM D 3212 using elastomeric gaskets conforming to ASTM F 477. All gaskets shall be factory installed on the pipe in accordance with the manufacturer's recommendations.
- Qualification for each manufacturer of polypropylene storm sewer pipe requires joint system conformance to ASTM D 3212 using elastomeric gaskets conforming to ASTM F 477 and a formal quality control plan for each plant proposed for consideration.
- A Manufacturer's Certificate of Compliance shall be required and shall accompany the materials delivered to the project. The certificate shall clearly identify production lots for all materials represented. The Contracting Agency may conduct verification tests of pipe stiffness or other properties it deems appropriate.
- WSDOT Section 9-05.24(1) Polypropylene Culvert Pipe and Storm Sewer Pipe
- Polypropylene culvert and storm sewer pipe shall conform to the following requirements:
 - For dual wall pipe sizes up to 30 inches: ASTM F2736.
 - For triple wall pipe sizes from 30 to 60 inches: ASTM F2764.
 - For dual wall profile pipe sizes 36 to 60 inches: AASHTO MP 21, Type S or Type D.
 - Fittings shall be factory welded, injection molded or PVC.

The following pipe types are deleted and will not be allowed:

- Corrugated or spiral aluminum pipe

- Corrugated steel pipe
- Spiral rib steel pipe
- Corrugated polyethylene drainage pipe CPEP pipe

2. Acceptable Pipe Sizes:

12-inch is the minimum diameter pipe to be maintained by the City. With City approval, the pipe diameter may be reduced to a minimum of 8-inch, if the pipe capacity is adequate for design flows.

3. Storm Drain Markers:

Storm drain curb marker medallions are required, if feasible, at every catch basin that receives surface water drainage. If markers are not feasible, stencils or casting engravings shall be used. Markers are to be placed in locations approved by Public Works.

4. Pipe Slope:

Minimum pipe slope shall be 0.5%

5. Storm Testing:

All storm system shall be jetted, cleaned, and CCTV inspected prior to final acceptance into City maintenance.

6. Structure Locations and Appurtenances:

Maximum pipe run between structures shall 300-ft. For maintenance of structures, a truck turnaround shall be provided. Maximum distance between maintenance vehicle access and drainage structure shall be 150-ft. Structures located in non-pavement areas shall include 2-ft wide asphalt ring around structure lid.

7. Pipe Deflections:

Once backfill is complete, the line and grade at pipe flow line leaving standing water greater than ½-inch in depth shall not be accepted and must be repaired prior to acceptance by the City.

8. Pipe Anchors:

Pipe anchor shall include 1" PVC pipe to be installed through the concrete anchor below the pipe to allow passing of ground water.

9. Drainage Structures:

The most updated WSDOT Standard Plans Section B and City of Kenmore Standard Details shall be used to determine acceptable design standards.

10. Drainage Structures Ladders:

Ladders required within drainage structures shall not block inlet or outlet pipes and must be accessible from structure opening.

11. Submerged and Surcharged Pipe:

The 100-year design elevation of downstream stormwater facilities such as stormwater ponds or vaults shall be at or below all pipe inverts. Exception to this standard is the pipe from the first catch basin just upstream of the stormwater facility may be submerged to allow pipe inlet to facility to be submerged.

CHAPTER 5 – Flow Control Design

The City of Kenmore has made minor changes to Chapter 5 of the SWDM. The following requirements apply as applicable in this chapter:

The King County Flow Control Applications Map included with the SWDM shall not be applied in the City of Kenmore. The Swamp Creek basin is a flood problem flow control area (level 3) and the remainder of the City of Kenmore is a conservation flow control area (level two) except for project sites with identified downstream flooding problems that may require a higher level of flow control for impact mitigation.

CHAPTER 6 – Water Quality Design

The City of Kenmore has added supplemental information and made minor changes to Chapter 6 of the SWDM, as described below.

Change to SWDM

- The King County Water Quality Applications Map included with the SWDM shall not be applied in the City of Kenmore. All of the City of Kenmore is a basic water quality treatment area unless the proposed land use triggers enhanced basic water quality treatment.
- The City of Kenmore allows bioretention to be used for presettling, but it must be designed to meet presettling requirements listed in 6.5.1 (Presettling Requirement).

DEFINITIONS

The City of Kenmore has made the following changes to the Definitions Section of the SWDM. Project proponents should refer to the county document for other definitions.

Term (page)	Action
<p>Erosion hazard area (p 9 of SWDM Definitions)</p>	<p><i>Replace as follows (from Section 18.20.940 KMC):</i></p> <p>Erosion hazard areas means those areas identified by the United States Department of Agriculture Natural Resources Conservation Service or identified by a special study as having a “moderate to severe” or “very severe” erosion potential.</p>
<p>Flood hazard area (p 10 of SWDM Definitions)</p>	<p><i>Replace as follows (per Section 18.20.1070 KMC):</i></p> <p>Flood hazard areas means those areas in the City subject to inundation by the base flood (see “Area of special flood hazard”) and those areas subject to flood risks from channel relocation or stream meander including, but not limited to, streams, lakes, wetlands and closed depressions. The latter flood hazard areas may extend outside of the area of special flood hazard mapped by FEMA, but are defined and designated by the City.</p>
<p>Landslide Hazard Area (page 15 of SWDM Definitions)</p>	<p><i>Replace as follows (per Section 18.20.1570 KMC):</i></p> <p>Landslide hazard areas means areas that are potentially subject to risk of mass movement resulting from a combination of geologic, topographic, and hydrologic factors including: bedrock, soil, slope gradient, slope aspect, geologic structure, ground water, or other factors.</p>

APPENDICES

The City of Kenmore has made the following changes to the Appendices section of the SWDM. Project proponents should refer to the county appendices where referenced below.

Appendix A: Maintenance Requirements for Flow Control, Conveyance, and WQ Facilities – The City of Kenmore has made no changes, and Appendix A applies in its entirety to the City of Kenmore.

Appendix B: Master Drainage Plan Objective, Criteria and Components, and Review Process – This appendix does not apply within the City of Kenmore.

Appendix C: Simplified Drainage Requirements

This is a separately bound document included with the SWDM. The City of Kenmore has made the following changes to Appendix C of the SWDM. All other parts of the appendix apply to the City of Kenmore. Appendix C provides guidance for many of the low impact development (LID) techniques.

C.2.9.2 shall be modified as follows:

C.2.9.2 RESTRICTED FOOTPRINT

Restricted footprint means the recording of a covenant that limits the amount of future impervious surface coverage on a site/lot to an amount less than the norm as specified below:

1. For single family residential sites/lots that are smaller than 22,000 square feet, any recorded limit on total impervious surface less than a norm of 4,000 square feet or the maximum allowed by the site/lot's zoning, whichever is smaller, qualifies for a restricted footprint credit equal to the difference in square footage. In other words, for every square foot that the recorded limit is below the norm, an equal area of actual proposed target impervious surface is credited as mitigated subject to Minimum Design Requirement in Section C.2.9.1.
2. For single family residence sites/lots that are between 22,000 square feet and 250,000 square feet, any recorded limit of total impervious surface in an amount less than a norm of 4,000 square feet or 4% of the site/lot area, whichever is greater, qualifies for a restricted footprint credit equal to the difference in square footage. For every square foot that the recorded limit is below the norm, an equal area of actual proposed target impervious surface is

credited as mitigated subject to Minimum Design Requirement 2 in Section C.2.9.1.

3. For single family residential sites/lots that are greater than 250,000 square feet, no restricted footprint credit is available.
4. For multi-family, townhome and commercial sites/lots, any recorded limit on total impervious surface less than the maximum allowed by the site/lot's zoning, qualifies for a restricted footprint credit equal to the difference in square footage. In other words, for every square foot that the recorded limit is below the norm, an equal area of actual proposed target impervious surface is credited as mitigated subject to Minimum Design Requirement in Section C.2.9.1.

Appendix D: Construction Stormwater Pollution Prevention (CSWPP) Standards – This is a separately bound document included with the SWDM. The City of Kenmore has made no changes and this appendix applies in its entirety to the City of Kenmore.

REFERENCE

Table Ref-1 identifies which reference sections in the SWDM apply and those that do not apply to the City of Kenmore. Table Ref-2 lists additional City of Kenmore references that apply.

Table Ref-1. Applicability of SWDM References to projects in the City of Kenmore

No.	Description	Action
1	KCC 9.04 Surface Water Runoff Policy	This reference document shall be deleted in entirety. Project proponents should refer to Chapter 13.35 KMC.
2	Adopted Critical Drainage Areas	This reference document shall be deleted in entirety. Project proponents should refer to Chapter 18.55 KMC.
3	Other Adopted Area Specific Drainage Requirements	This reference document shall be deleted in entirety. Project proponents should refer to City codes, ordinances, and sensitive areas maps for description and requirements within sensitive areas. The project proponent shall also work with the City on additional requirements that may apply to their project.
4	Other Drainage Related Regulations and Guidelines A. Grading Code Soil Amendment Standard B. Clearing & Grading Seasonal Limitations C. Landscape Management Plan Guidelines D. Shared Facility Maintenance Responsibility and Guidance	A. Applicable. B. Not applicable. See Section 15.25.150 KMC. C. Applicable. D. Applicable.
5	Wetland Hydrology Protection Guidelines	These guidelines apply.

No.	Description	Action
6	<p>Hydrologic/Hydraulic Design Methods</p> <ul style="list-style-type: none"> A. Infiltration Rate Test B. Pond Geometry Equations C. Introduction to Level Pool Routing D. Supplemental Modeling Guidelines 	<p>This reference section is applicable.</p>
7	<p>Engineering Plan Support</p> <ul style="list-style-type: none"> A. King County Standard Map Symbols B. Standard Plan Notes and Example Construction Sequence C. Storm Filter Facility Access and Cartridge Configuration 	<ul style="list-style-type: none"> A. Applicable. B. Replace with City’s standard plan notes. Contact City for most current version of notes. C. Not applicable. Delete this reference subsection in entirety.
8	<p>Forms and Worksheets</p> <ul style="list-style-type: none"> A. TIR Worksheet B. Offsite Analysis Drainage System Table C. Water Quality Facility Sizing Worksheets D. Flow Control and Water Quality Facility Summary Sheet and Sketch E. CSWPPP Worksheet Forms F. Adjustment Application Form and Process Guidelines G. Dedication and Indemnification Clause H. Bond Quantities Worksheet I. Maintenance and Defect Agreement J. Declaration of Covenant K. Drainage Release Covenant L. Drainage Easement M. Flow Control BMP Covenant (see replacement form name below). N. Impervious Surface Limit Covenant O. Clearing Limit Covenant P. River Protection Easement Q. Leachable Metals Covenant 	<ul style="list-style-type: none"> A. Contact City for Applicable Form. B. Contact City for Applicable Form. C. Contact City for Applicable Form. D. Contact City for Applicable Form. E. Contact City for Applicable Form. F. Contact City for Applicable Form. G. Contact City for Applicable Form. H. Contact City for Applicable Form. I. Contact City for Applicable Form. J. Contact City for Applicable Form. K. Contact City for Applicable Form. L. Contact City for Applicable Form. M. Contact City for Applicable Form. N. Contact City for Applicable Form. O. Contact City for Applicable Form. P. Contact City for Applicable Form. Q. Contact City for Applicable Form.
9	<p>Interim Changes to Requirements</p> <ul style="list-style-type: none"> A. Blanket Adjustments B. Administrative Changes 	<p>Applicable.</p>
10	<p>King County Identified Water Quality Problems</p>	<p>Delete in entirety</p>

No.	Description	Action
<p>11</p>	<p>Materials A. (VACANT) B. (VACANT) C. Bioretention Soil Media Standard Specifications D. (VACANT) E. Roofing Erodible or Leachable Materials</p>	<p>A. Not applicable. B. Not applicable. C. Applicable. D. Not applicable. E. Applicable.</p>
<p>12</p>	<p>(VACANT)</p>	<p>Not applicable</p>
<p>13</p>	<p>(VACANT)</p>	<p>Not applicable</p>
<p>14</p>	<p>Supplemental Approved Facilities A. Approved Proprietary Facilities B. Approved Public Domain Facilities</p>	<p>A. Applicable. B. Applicable.</p>



APPENDIX G

TRAFFIC IMPACT ANALYSIS GUIDELINES

CITY OF KENMORE, WA TRAFFIC IMPACT ANALYSIS GUIDELINES		
18120 68 th Ave NE, Kenmore, WA 98028	425-398-8900 www.kenmorewa.gov	



TRAFFIC ANALYSIS REPORT

To adequately review development proposals, the city may require that the applicant provide a traffic analysis to help determine the need for roadway, non-motorized and transit improvements to serve the proposed use and address the traffic impacts on the public transportation system. The following guidelines have been established to assist a professional engineer in providing the information needed to adequately analyze the development proposal.

The written report should include the following information utilizing appropriate charts and graphics:

1. A description and location of the development site
2. Proposed land uses and intensities
3. The area of influence of site traffic.
4. A right of way access plan for the development, including the proposed internal circulation and available sight distances at major entry points.
5. A vicinity map and site plan.

Existing conditions and analysis:

1. Description of the existing conditions of streets, intersections, non-motorized facilities and transit improvements in the area that will potentially be impacted.
2. Information on existing street widths, number of lanes, intersection geometrics, locations of traffic signals and other types of traffic control, parking restrictions, sidewalks, bicycle paths, transit stops, transit amenities (e.g., shelters) and transit routes should also be included.
3. 24-hour traffic counts on the affected streets and turning movement counts during morning and evening peak periods at the impacted intersections. Counts shall be collected a minimum of 3 consecutive days including Tuesday, Wednesday, and Thursday. Data used shall not be older than 2 years from the date the analysis is performed.
4. Capacity and level of service analysis for the existing conditions of the affected streets and impacted intersections. Refer to KMC 12.80.030 for the City's level of service standards.
5. Traffic crash data for the influence area both for mid-block locations and intersections for the last five years.

Calculation, analysis, and representation of the following future conditions:

1. Trip generation during the 24-hour and morning and evening peak periods, and peak hour of the generator for each land use category in the project should be calculated and shown. A trip table including type of land use intensity, trip generation rates and trips generated should be prepared.
2. The distribution of generated traffic and assignment of that traffic to the street system during morning and evening peak periods and peak hour of the generator along with reasons for the assumed distribution.
3. Future 24-hour and peak period traffic volumes and assignments upon completion of the development (by phases if applicable).
4. Capacity analysis and levels of service for morning and evening peak periods and for the peak periods of the generator, if necessary. Refer to KMC 12.80.030 for the City's level of service standards.
5. Street access and transit improvement plan with recommendations by development phases identifying all needed improvements and the improvements that are the responsibility of the applicant. These

recommendations should be based on both the morning and evening peak hour projected volumes with an emphasis on the safety aspects of the design.

6. Proposed driveway locations, geometrics, sight distances and turn restrictions taking into consideration the proximity of nearby intersections and anticipated queues based on arrival rates, should be shown. Sight distance data at driveways using city standards where horizontal and vertical alignments are critical should be included.
7. Impact of the development on the street network, signal warrants, crash frequency, and mitigation techniques should be included wherever appropriate.
8. Concise summary of findings and recommendations for the approval of the City before the development plan is presented to the City's Hearings Examiner for approval.

Additional information that may be requested:

1. Estimates of the cost of the recommended improvements and/or information on proposed street improvements in the area by the City, County, or WSDOT.
2. A more intense analysis using network operational and simulation software for special projects.

LEVELS OF ANALYSIS

The following guidelines are provided to assist the applicant and their consultants determine the size of the area to study for a traffic impact analysis and the detail of the analysis that the City will require. There are three levels of analysis. Each one has a different emphasis on the level of detail. Each development may have different or unique traffic issues and concerns that may require further study. The City may require a higher level of analysis or the submittal of additional information due to specific project location.

Level One – On-Site Analysis:

Description: Placement and design of internal (on site) features such as parking layout, access to public streets, site circulation, intersection sight distance, pedestrian circulation, delivery and loading areas and internal public street layout.

Threshold: Small commercial or residential development or an addition to an existing development creating less than 10 peak hour trips.

Level Two – Project Area Analysis:

Description: On-site analysis (Level One) plus the impact of the development and its traffic on adjacent and affected area streets, impacted intersections, adjoining developments, pedestrians and public transit facilities. The project analysis will include those facilities as designated by the City.

Threshold: Small to medium sized residential and commercial developments creating between 10 and 75 more peak hour trips.

Level Three – Corridor Analysis:

Description: On-site analysis (Level One) plus project area analysis (Level Two) plus the impact of the proposed development on a larger study area and the street and highway system that is being impacted by the addition or improvement of arterial streets and by other large developments in the study area.

Threshold: Large commercial and residential developments creating 75 or more peak hour trips.

Pipeline Projections:

Description: Prior to beginning the traffic analysis, the applicant's consultant shall meet with the City to determine which "pipeline" projects must be included in the analysis. Pipeline projects are defined as projects (both private and public) that have received some level of approval but full development has not been completed.

Threshold: All traffic analysis shall include the effect of those pipeline projects designated by the City.